

# INVESTIGATIONS INTO COST REDUCTIONS OF X-BAND INSTRUMENTATION \*

D. Van Winkle, S. Tantawi, V. Dolgashev, J Fox SLAC, Menlo Park, CA, 94025, U.S.A.

## Abstract

The prohibitive costs of commercial test equipment for making fast and accurate pulsed phase and amplitude measurements at X-Band result in decreased productivity due to shortages of shared equipment across the test laboratory. In addition, most current set-ups rely on the use of pulsed power heads which do not allow for the measurement of phase thereby limiting the flexibility of available measurements. In this paper, we investigate less expensive in-house designed instrumentation based upon commercial satellite down converters and widely available logarithmic detector amplifiers and phase detectors. The techniques are used to measure X-Band pulses with widths of 50 ns to 10's of usec. We expect a dynamic range of 30-40 dB with accuracies of better than +/- 0.1 dB and +/- 1 degree of phase. We show preliminary results of the built and tested modules. Block diagrams of the down conversion scheme, and the architecture of a multi-signal X-band RF monitor and measurement system is illustrated. Measured results, and possible modifications and upgrades are presented.

source. Another disadvantage was the complex cabling required for each measurement. Our new system essentially follows this same architecture but moves the converter, detector and local oscillator to a modular block which is directly mounted on to a waveguide coupler in the overall test system.

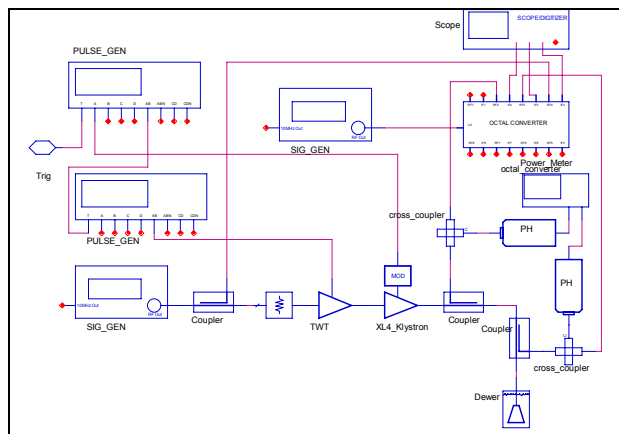

Figure 1: Original test system block diagram.

## MOTIVATION

In the klystron lab we use 50 MW XL4 klystrons designed for operation with up to 200 MHz bandwidth around 11.424 GHz to test various accelerating structures and cavities. Of particular interest in many of these tests is the phase and amplitude response of these structures under pulsed conditions. We have been working on developing a modular system of measurement instruments to help us characterize and monitor these devices as they are being tested. In the one application to date, we are measuring the reflected power from a tuned cavity. When the cavity is in resonance with the excitation, we can extract parameters from the decay of the stored energy. There are plans for other applications for this detector in the near future.

## SYSTEM DESCRIPTION

The *main goals* for the system are:

- Absolute amplitude accuracy of +/- 0.1 dB
- Relative phase accuracy +/-1 degree
- Low cost
- Low infrastructure overhead

The system used in the past is shown in figure 1. Essentially, each monitored signal is cabled to a converter box where it is down converted to a lower frequency. Then, each of those signals is routed to an IF detector box which contains an Analog Devices AD8302 [1]. One of the main disadvantages of the old system was the requirement for an additional stable X-Band microwave

To perform the conversion we decided upon a commercially available Low Noise Block converter (LNB) used for satellite TV reception. Using a commercial down converter intended for satellite communications offers an attractive cost advantage. However, a satellite receiver does not require absolute amplitude gain stability on the down converted signal (the communications applications all use automatic gain control (AGC) functions to normalize the down converted signal). Similarly, the absolute phase of the down converted signal has no specification, as what is important for communications purposes is relative phase accuracy of signal components in a narrow communications channel. To mitigate the risks of using unspecified parameters, we plan on carefully characterizing each LNB as it is assembled. In addition, forward power levels will be set using an external calibrated power meter.

These LNB devices typically cost ~\$250. The LNBs require a 10 MHz reference to lock the internal PLL at 10.25 GHz. This phase lock loop (PLL) LNB down converts our pulsed signal (11.324 to 11.524 GHz) to an IF (1.074 to 1.274 GHz) which is then detected in the AD8302 on a custom made PCB housed in a shielded enclosure. Throughout this paper we will refer to 11.424 GHz as the signal frequency and 1.174 GHz as the IF frequency. This device actually is able to detect the full 200 MHz band width around the 11.424 GHz, therefore, 11.424 GHz is merely used for consistency).

\*Work supported by the U.S. Department of Energy under contract #DE-AC02-76SF00515

The LNBs are manufactured for satellite reception and as a consequence contain 3 stages of low noise high gain amplifiers on the front end to detect low power signals. Since our systems has plenty of power (50 MW), these amplifiers are unnecessary and so we remove them and replace them with 30 dB of attenuation.

The AD8302 requires a reference signal to compare to so we generate a 1.174 GHz reference using another LNB and some combining circuitry inside a reference chassis. We chose to run the 10 MHz reference, the 1.174 GHz reference and the DC power all on the same coax cable. Each detector would require a separate feed of these signals, but we designed the system so that it can be daisy chained. The overall final system block diagram is shown in figure 2 for measuring a resonant cavity (without a field probe); measuring forward and reflected power and phase.

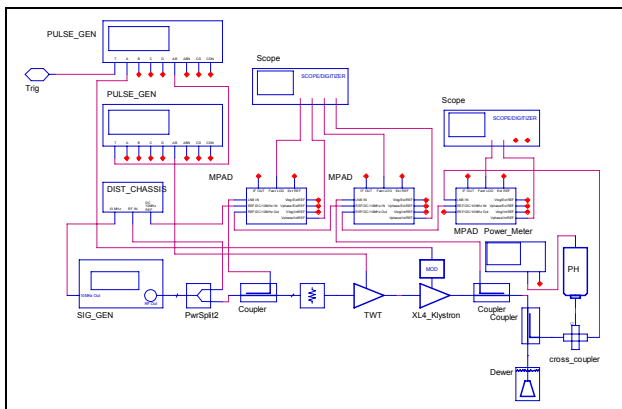

Figure 2: New system block diagram.

### DETAILED DESIGN

The system is made up of two parts; the distribution chassis and the modular phase amplitude detectors.

#### Distribution Chassis

The distribution chassis provides the DC power for the LNB and the interface board. It also provides the 10 MHz reference for the phase locked oscillator contained within the LNB. In addition, the nominal 1.174 GHz reference used for phase detection is also provided from the chassis. This chassis, like the overall system uses commercial parts to create the desired output containing DC/10 MHz/1174 MHz all on one cable. The block diagram of the distribution chassis is shown in figure 3.

The 10 MHz reference is fed in from the back of the 11.424 GHz signal generator. The 10 MHz is split and sent to a reference LNB which creates the 1.174 GHz phase reference for all the modular detectors. This reference is fed back into the interface board and amplitude leveled using the internal leveling circuit contained within the modular phase detector. The DC, 1.174 GHz reference and 10 MHz reference are all fed into a high current combiner and brought back out to the

front panel for distribution to the daisy chained Modular Phase Amplitude Detectors (MPAD). Each Chassis can provide up to 5 Amps of DC current at 18V.

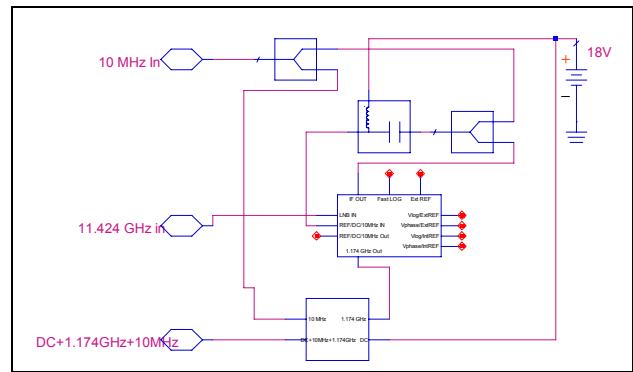

Figure 3: Distribution chassis block diagram.

#### Modular Phase Amplitude Detectors

The modular phase amplitude detectors are made up of two parts; the LNB, and an interface board. The block diagram of the combination is shown in figure 4.

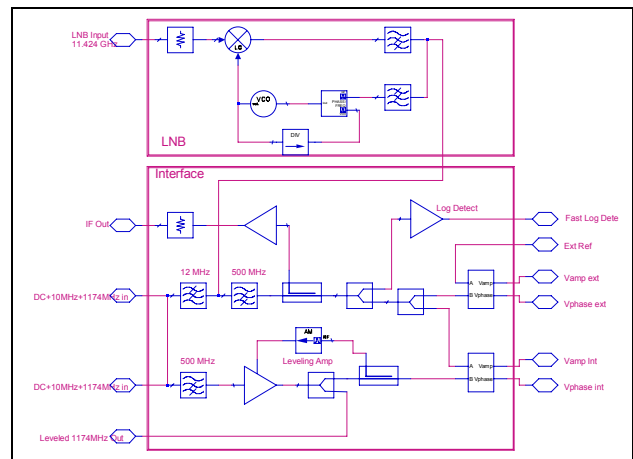

Figure 4: Modular phase amplitude detector block diagram.

The core of the MPAD is the AD8302 amplitude/phase detector from Analog Devices. The function of the AD8302 is to do an amplitude comparison between a reference signal and an unknown signal. The reference signal (1174 MHz) is extracted from the DC+10 MHz+1174 MHz signal through a tap from the main line through a 500 MHz high pass filter. The reference signal is then leveled through a tightly controlled leveling loop which holds the signal amplitude to +/- .1 dB. The DC for the interface board and DC and 10 MHz PLL reference for the LNB is extracted after the 12 MHz low pass filter. The IF from the LNB is separated from the 1174 MHz reference by the 12 MHz filter and is passed instead to another 500 MHz high pass filter. The IF signal is then passed to the internal reference phase/amplitude detector, a fast rise time log detector and an external reference phase/amplitude detector.

It is obviously important that the 10 MHz and the 1174 MHz references do not leak through to the IF path and this has been one of the more challenging aspects of this design.

A photograph of the package interface board and LNB is shown in figure 5. Because the LNB uses WR75 waveguide and the test lab uses WR90 waveguide, we had to make a special adapter using modified flanges. By modifying an internal trace, each LNB is hand trimmed to have a return loss of better than 15 dB. A better return loss could be obtained deemed necessary.



Figure 5: Photograph of modular phase amplitude detector.

**TEST RESULTS**

The original test application for this detector is shown in figure 2. When a cavity is tuned on resonance, it is expected that the cavity will initially reflect all power and then as the cavity fills, the reflected power will exponentially decay. Once the cavity is filled, the reflected power will settle to a fixed level determined by the cavity coupling and impedance of the guide and cavity. Results from tests on a laboratory cavity are shown in figure 6. Figure 6 shows the reflected pulse amplitude and phase as well as the fast log amplifier detector response.

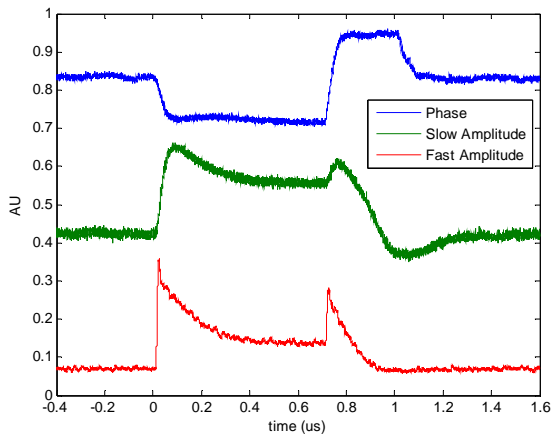

Figure 6: Forward detected pulse.

For clarity, the results shown in figure 6 are from pulsing between two differing power levels; had this been a true pulsed measurement, the “off signals end up

looking very noisy because the phase of the input signal is no longer present and as a consequence the phase is detected against noise.

The digitized signal will need calibration data to determine absolute power and phase levels. Preliminary plots of these curves are shown in figure 7 and 8.

One potential drawback to this phase detector is the 180 degree unambiguous range (the "mirrored" response, signals pi+angle and pi-angle have the same value). Careful attention will have to be paid to keep the phase of interest centered in the phase detection curve. Ideally, phase changes will not cross the 180 degree inflection point.

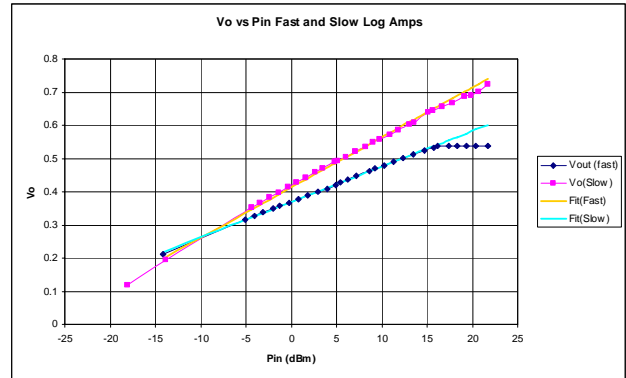

Figure 7: Amplitude calibration curve.

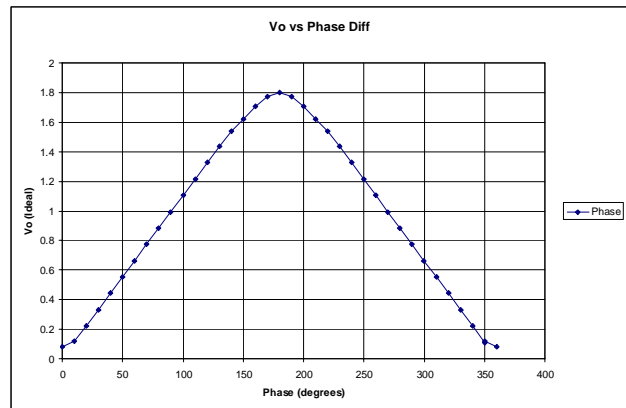

Figure 8: Phase calibration curve.

**FUTURE DIRECTIONS**

We will be building 10 more of these devices for further testing and development of more applications. In addition, since the current design contains a linear regulator which drops 18V to 5V (to supply 18V to the LNB and 5V to the detection circuits). We will be evaluating a switching supply for better DC power efficiency. This should help reduce the fairly significant temperature rise which occurs due to the wasted power.

**REFERENCES**

[1] AD8302 Data sheet [http://www.analog.com/UploadedFiles/Data\\_Sheets/AD8302.pdf](http://www.analog.com/UploadedFiles/Data_Sheets/AD8302.pdf).