

DESIGN AND TEST OF A 100MW X-BAND TE_{01} WINDOW

Jeff Neilson and Lawrence Ives
 Calabazas Creek Research, Inc.
 20937 Comer Dr, Saratoga, CA 95070
 Email: jeff@calcreek.com

Sami G. Tantawi
 Stanford Linear Accelerator Center
 P.O. Box 4349, Stanford, CA 94309

Research at Stanford Linear Accelerator Center (SLAC) is in progress on a TeV-scale linear collider that will operate at 5-10 times the energy of present-generation accelerators. This will require development of high power X-Band sources generating 50 -100 MW per source. Conventional pillbox window designs are capable of transmitting peak rf powers up to about 30 MW, well below the desired level required for the use of a single window per tube. SLAC has developed a 75 MW TE_{01} window [1] that uses a 'traveling wave' design to minimize fields at the window face. Irises match to the dielectric window impedance, resulting in a pure traveling wave in the ceramic and minimum fields on the window face. The use of the TE_{01} mode also has zero electric field on the braze fillet. Unfortunately, in-band resonances prevented this window design from achieving the desired

75MW power level. It was believed the resonances resulted from sudden steps in the circular guide to match the 38mm input diameter to the overmoded (TE_{01} and TE_{02} mode propagating) 65 mm diameter of the window ceramic.

Calabazas Creek Research Inc. is currently developing a traveling wave window using compact, numerically optimized, parabolic tapers to match the input diameter of 38mm to the window ceramic diameter of 76mm (Figure 1). The design is projected to handle 100 MW of pulse power with a peak field at the window face of 3.6 MV/m.

Cold test of the window has shown the return loss to be better than -25 dB over a 100 MHz bandwidth and to be resonance free (Figure 2). The window is scheduled for high-power testing in July 2003 at the SLAC.

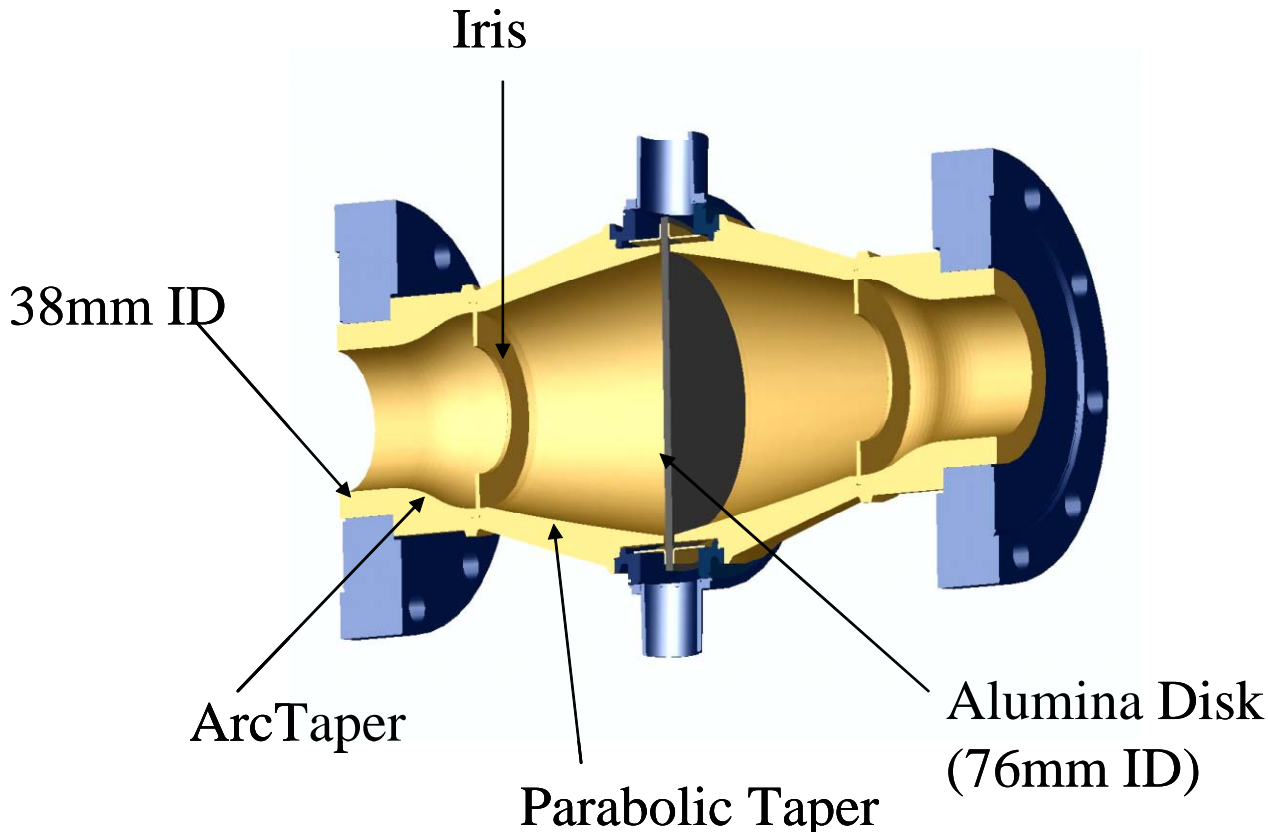

Figure 1. Cross section of high power X-Band window.

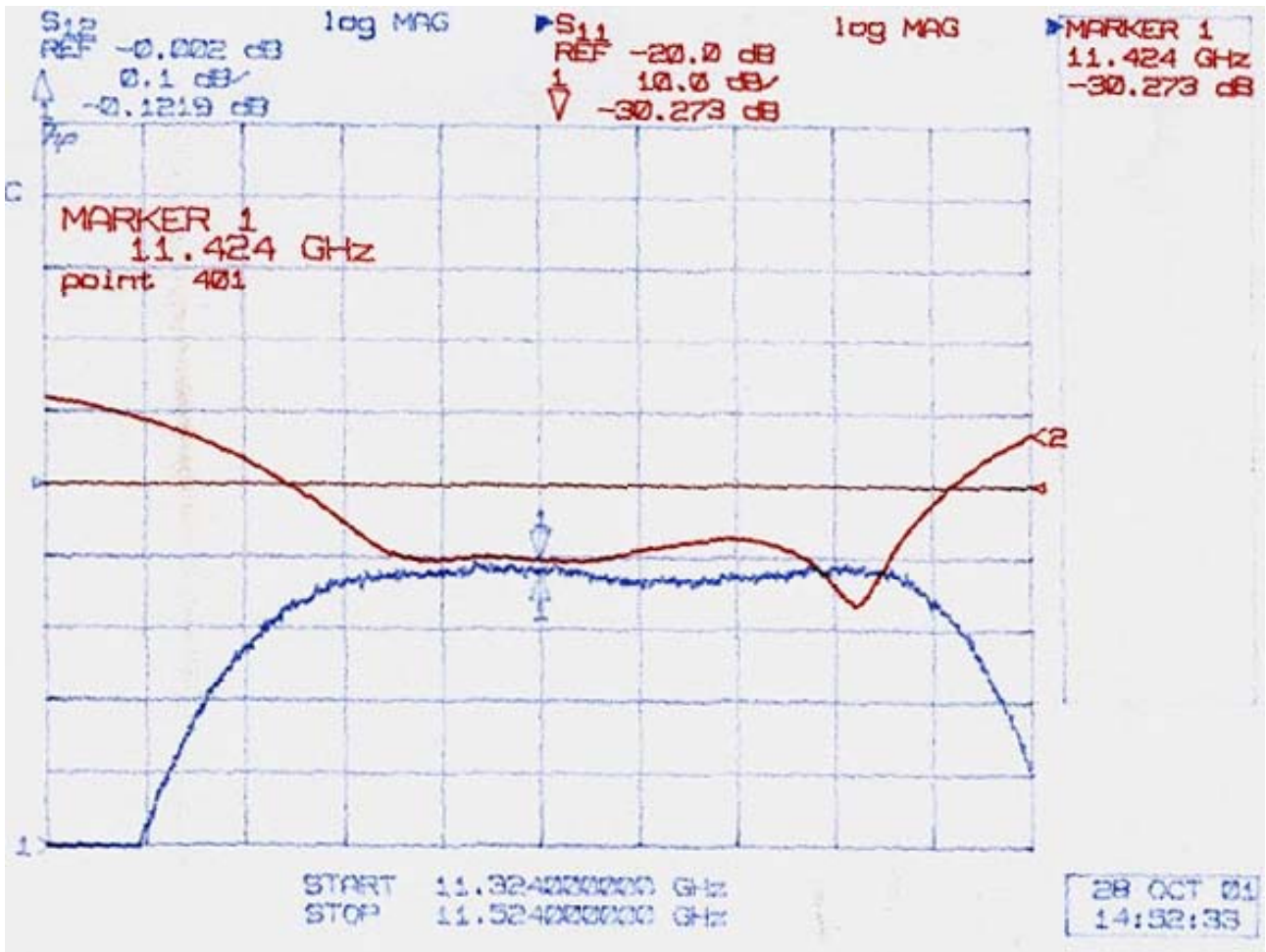

Figure 2. Cross-section of high power X-Band window.

This work is supported by U.S. DOE Small Business Innovative Research grant DOE DE-FG03-97ER82343.

REFERENCE

1. W.R Fowkes, R.S. Callin, E.N. Jongewaard, D.W. Sprehn, S.G. Tantawi, A.E. Vlieks, "Recent advances in high power RF windows at X band", AIP Conf.Proc.474:289-295,1999