

# THE SSRL LINACS FOR INJECTION TO THE STORAGE RING AND RF GUN TESTING\*

Sanghyun Park and James N. Weaver  
Stanford Synchrotron Radiation Laboratory  
P.O.Box 4349, Stanford, California 94309, USA

## Abstract

The Stanford Synchrotron Radiation Laboratory (SSRL) operates two linac systems. One has three SLAC type linac sections powered by two klystrons for injection of electrons at 120 MeV into the booster ring, boosting the energy to 2.3 GeV to fill the SPEAR. After the ramping, the SPEAR stores up to 100 mA of the beam at 3.0 GeV. The preinjector consists of a thermionic RF gun, an alpha magnet, and a chopper along with focusing magnets. The other has one 10 foot section powered by the injector klystron for the testing of RF gun with photocathode, which is driven by a separate klystron. This paper describes present systems with their operational parameters, followed by plans for the upgrades and RF gun development efforts at the SSRL.

## Introduction

The SSRL injector linac has been in operation since 1990 [1] providing electron bunches at 120 MeV for the booster synchrotron, which in turn inject the particles at 2.3 GeV to the SPEAR, where the energy is ramped to 3.0 GeV and stored for synchrotron radiation. The SPEAR stands for Stanford Positron Electron Accumulator Ring and was originally built for high energy physics research. The ring used to be injected by the SLAC two-mile linac until the injector/booster system was completed.

Under normal conditions the SPEAR stores up to 100 mA of current in its 234 meter circumference vacuum chamber. The life time  $\tau$  of the beam defined by  $\tau = -(\frac{1}{I} \frac{dI}{dt})^{-1}$  is up to 30 hours at  $I=100$  mA and keeps increasing as the beam current decays. One parameter that remains fairly constant for the full range of the current is the vacuum quality  $Q_v$  as defined by the product of current  $I$  and the life time  $\tau$ . Then the time dependence of the stored current is  $I(t) = I_0/[1 + I_0 t/Q_v]$ , where  $I_0 = I(t = 0)$ . In 24 hours after the fill, more than half of the initial current remains, to be dumped in preparation of a new fill, which takes about 30 minutes. The thermionic RF gun and linac are left on at all times for the consideration of vacuum and thermal stability, while the booster synchrotron is turned off after the injection to reduce the electrical power cost.

Except for a short period of time needed for the injection, the gun/linac assembly is available for other tasks such as accelerator physics experiment, testing of a new electron source, and diagnostic development. Adequate shielding against the radiation and availability of RF power and other existing utilities make the linac vault an excellent location for a test stand.

\* Work supported in part by Department of Energy Contract DE-AC02-76SF00515 and Office of Basic Energy Sciences, Division of Chemical Sciences.

## The SSRL Injector

Up until the Summer of 1995, the SSRL injector system had three XK-5 klystrons. With a new demand on more RF power, one of them was replaced by a Type 5045 klystron. Presently this klystron powers one thermionic RF gun and two linac sections. It also provides, through the waveguide directional couplers, input signals for the other two klystrons. The RF power to the gun is controlled by a waveguide power divider and a waveguide phase shifter. The second output port of that power divider is currently terminated by a dummy load, but it is planned to be connected to the fourth linac following the photocathode RF gun. The third linac as a part of the injection linac system is powered by one klystron. The geometric system layout is shown in Fig. 1 and the overall RF system schematic is shown in Fig. 2.

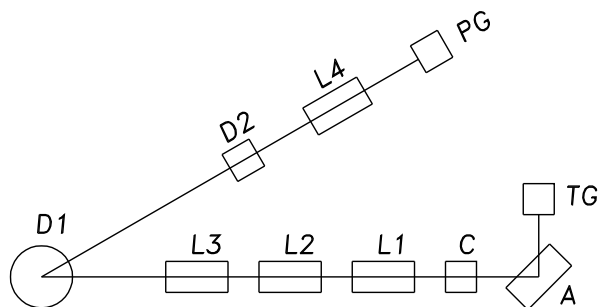

Figure 1: The layout of the SSRL injector and the gun test stand showing thermionic and photocathode gun (TG, PG), alpha magnet(A), chopper(C), linacs (L1 through L4), and dumps (D1, D2).

Each bunch out of the thermionic gun (TG) has about 70 pC of charge at the energy of up to 2.5 MeV. An alpha magnet compresses the bunch length to about 4 ps so that the bunch occupies 4 degrees of RF phase in the linac, leading to less than 0.5% of energy spread after the linac L3. Since the gun produces bunches for every RF bucket over the period slightly shorter than the macro pulse length of 2  $\mu$ s, the chopper (C) selects three consecutive bunches and throws out the rest. By this, the beam loading at the linac and the booster synchrotron is minimized and the energy of the injected beam is stable. The alpha magnet also filters out particles with lower momentum as set by the position of the scraper at the magnet. When the beam is not used for injection, it is dumped at D1. The gun emission is monitored by measuring the charge collected there, in addition to the current transformers.

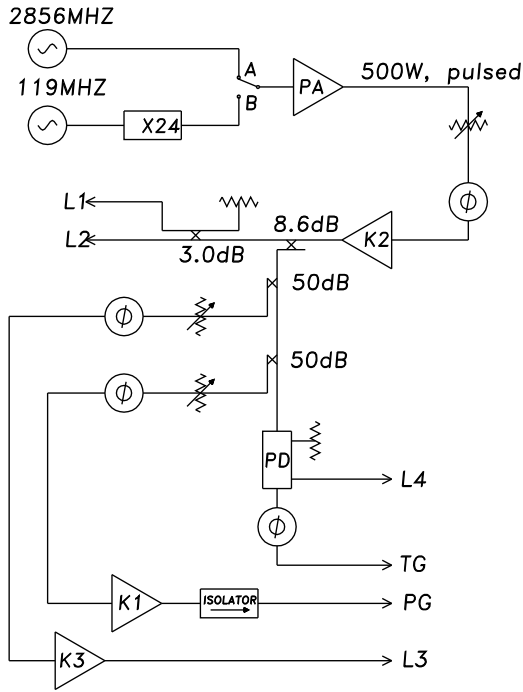

Figure 2: The RF system to drive guns (TG for thermionic, PG photocathode) and linacs (L1 through L4). Shown here are frequency multiplier (X24), preamplifier (PA), klystrons (K1, K2, and K3), variable power divider (PD) along with phase shifters, attenuators, and directional couplers.

Both guns (thermionic and photocathode) are standing wave structures that reflect a large portion of the driving RF power at the beginning and at the end of the pulse. For the thermionic gun, this reflection is considered to be tolerable since the forward power is tapped from the klystron K2 at the level 8.6 dB down from the K2 output, and the reflected power reaching K2 is minimal. In the case of the photocathode gun, however, the reflected power as a whole reaches the klystron K1 unless an isolator is employed in between. This reflection may cause instability and, when the gun is driven to a high power level, it can damage the klystron.

The pulse repetition rate of 10 Hz for the klystrons is sufficient for injection and limited by the power supply ratings and radiation shielding considerations. The system clock is derived from the 60 Hz AC line so that every sixth zero crossing of the AC voltage triggers the S-band RF system. Since the first two linac sections are phase matched, the RF phase and amplitude at the third section, powered by a separate klystron, is controlled by the medium power (few hundred watts) attenuator and phase shifter. This enables the manipulation of beam energy and bunch length, and facilitates the measurements of beam parameters.

The specifications of the three klystrons are shown in Table 1. For the purpose of the system reliability and longevity, these klystrons are operated at much lower beam power and below saturation.

Table 1: Test data for the three klystrons

Klystrons	K1	K2	K3
Type	XK-5	5045	XK-5
$P_{rf, max}$ (MW)	31.7	61.6	33.3
Beam Voltage (kV)	270	350	270
Beam Power (MW)	75.3	139.3	75.9
Microperveance	1.99	1.92	2.00
Efficiency (%)	42.1	44.2	43.9
Power Gain (dB)	50.3	55.4	51.9

### Thermionic RF Gun

The characteristics of the present thermionic RF gun has been well explored during its commissioning [1]. It has a demountable dispenser cathode of 6 mm diameter heated to 1000°C. For the purpose of thermal isolation, and to contain the RF fields in the cell, a tungsten spring around the cathode provides an interface to the gun cell. Unlike a photocathode gun where the electron bunch profile is controlled by the laser beam, the electron emission from a thermionic cathode is determined by the temperature distribution, which needs to be regulated in space and time. Also important is the beam loading, where almost every RF bucket is filled and bunches take away the RF energy with them. This leads to lowering of the accelerating gradient. Despite of this, the gradient is still much higher compared to a DC gun so that the emittance of the beam is useful for the applications requiring low emittance such as free-electron laser.

The electron bunches out of the gun have a wide spectrum of energy distribution with the peak intensity near the energy maximum of 2.5 MeV. The low energy tail of the distribution makes the bunch length almost one half of the RF period of 350 picosecond. Some portion of the electrons emitted from the cathode is accelerated back to the cathode. This back bombardment can cause increase in total current out of the gun, and thus more beam loading and less energy on a thermal time scale. The electrical power to the cathode heater sometimes needs to be manipulated to achieve a level of beam stability during the injection.

In order for the gun to generate stable bunches on a long term basis, it becomes necessary to stabilize the emission from the cathode. One way of achieving this is to divert the reflected beam away from the cathode by applying a steady state magnetic field perpendicular to the path of the beam. The ensuing deflection of the beam needs to be corrected for by similarly subjecting the beam to the second magnetic field. The underside of this scheme is degradation of the beam emittance. The protection of the cathode from back bombardment by means of magnetic bias is being evaluated for the feasibility and merit.

While the present thermionic gun was designed to produce low emittance beams, the transport system increases the emittance considerably. Reconfiguration of the beam line to best preserve the emittance is not realistic from the injection point of view. Re-designing of the gun is not feasible considering the cost and time it takes. One simple solution is to use a smaller size cathode. The present gun has a 0.250 inch diameter cathode and it is an

industrial standard size. We identified one with 0.125" diameter within the same category. One potential problem associated with the use of this small size cathode is the possible limitation in thermionic emission. With the emitting area just a quarter of the bigger unit, the smaller cathode needs to supply the same current at four times the current density. If we take the work function to be 2.8 eV and the operating temperature at 950°C, it is found that the temperature increase by 60°C is sufficient for the purpose.

### Photocathode RF Gun

As compared to a thermionic gun, a photocathode gun exhibits many advantages in terms of high current and brightness, flexibility in bunch shaping, and ability to control energy spread. There has been a number of projects around the world to realize a state of art photoinjector, with varying degree of success [2]. In an effort to generate electron beams suitable for driving an X-ray FEL, a new design of an S-band photocathode RF gun was made at SLAC [3].

Some important features of the new gun are summarized as follows: (1) extended half cell length for higher gradient, (2) coupling of the RF power to the gun through the full cell, (3) symmetrized half cell, which is powered through the iris, (4) extreme care exercised in the course of machining, (5) use of flat cathode plate, (6) use of Helicoflex™ O-ring to make an RF seal as well as a vacuum seal. At the test stand of SSRL, the gun has been subjected to up to 13 MW of RF power where the field gradient at the cathode was estimated at 140 MV/m, and the maximum energy of the dark current at 11 MV. This gun was moved to Brookhaven for characterization of photoelectron beam from the gun.

Two more units are under construction with varying degree of completion. For the unit designated for SSRL, some modification has been incorporated in the way the cathode plated is mounted. This gun, presently under cold test, will be installed at the SSRL test stand after some iteration for tuning and brazing. The emittance of the photoelectron beam is expected to reach  $1 \pi mm - mrad$ . A clean room to house the drive laser has been constructed adjacent to the linac vault. Final plumbing is currently underway to connect the gun and linac assembly to the klystrons.

As can be seen in Fig. 2, there are two master oscillators associated with this project. One is a 2856 MHz unit generating reference signal for the klystrons that power the thermionic gun and linac sections. The other is derived from the laser oscillator at 119 MHz. In order for the photoelectrons to leave the cathode at a predetermined RF phase, the RF system needs to be phase locked to this laser reference frequency. There are commercial sources available for the frequency multiplier that generates stable signal with an excellent spectral purity (spurious side bands are more than 70 dB below the carrier frequency amplitude).

With the 2856 MHz master oscillator, tuning is done either by changing the operating frequency or by adjusting the temperature of the gun and linac by means of circulating temperature controlled water along the channel. In this case, the selection switch is thrown to the position A. When a photoelectron beam is desired, the position B is selected. Since the laser oscillator is

not tunable, the cooling water temperature must be set to bring the system to the resonance.

### Conclusion

A thermionic RF gun operating at 2856 MHz has been used as a preinjector to the SLAC type linac sections. Some areas of improvement have been identified. A magnetic deflection of the beam at the half cell to mitigate the back bombardment to the cathode is being studied. Present plan calls for a testing of the gun with a smaller size cathode in an effort to still lower the beam emittance.

For the production and characterization of photoelectron beam, components of the system are being readied. They are the RF gun of new design, drive laser, the RF systems for the gun and linac, and some diagnostic apparatus. The new gun is expected to produce electron beams at energy of over 10 MeV out of its 1.6 cell cavities. The RF power requirement is at least 13 MW and may have to be higher for more beam energy. As the gun will be powered by one klystron exclusively, the use of a high power isolator before the gun seems to be compelling. The current milestone indicates that the first photoelectron beam will be available before the end of 1996.

### References

- [1] M. Borland *et al.*, Proc. 1990 Linac Conf.
- [2] S. Park *et al.*, Proc. 1994 Linac Conf.
- [3] D.T. Palmer *et al.*, Proc. 1995 Part. Accel. Conf.