

Electronics for Satellite Experiments

R.P. Johnson
*University of California at Santa Cruz and
 Santa Cruz Institute for Particle Physics
 Santa Cruz, CA 95065*

The tracking detector for the LAT science instrument on the GLAST mission is an example of a large-scale particle detection system built primarily by particle physicists for space flight within the context of a NASA program. The design and fabrication model in most ways reflected practice and experience from particle physics, but the quality assurance aspects were guided by NASA. Similarly, most of the electronics in the LAT as a whole were designed and built by staff at a particle physics lab. This paper reports on many of the challenges and lessons learned in the experience of designing and building the tracking detector and general LAT electronics for use in the NASA GLAST mission.

1. INTRODUCTION

The Large Area Telescope (LAT) of the Gamma-ray Large-Area Space Telescope (GLAST) mission [1]–[2] is a pair-conversion gamma-ray detector similar in concept to the previous NASA high-energy gamma-ray mission EGRET on the Compton Gamma-Ray Observatory [3]. High energy (>20 MeV) gamma rays convert into electron-positron pairs in one of 16 layers of tungsten foils. The charged particles pass through up to 36 layers of position-sensitive detectors interleaved with the tungsten, the “tracker,” leaving behind tracks pointing back toward the origin of the gamma ray [4]. After passing through the last tracking layer they enter a calorimeter composed of bars of cesium-iodide crystals read out by PIN diodes. The calorimeter furnishes the energy measurement of the incident gamma ray. A third detector system, the anticoincidence detector (ACD), surrounds the top and sides of the tracking instrument. It consists of panels of plastic scintillator read out by wave-shifting fibers and photo-multiplier tubes and is used to veto charged cosmic-ray events such as electrons, protons or heavier nuclei.

In the LAT the tracker and calorimeter are segmented

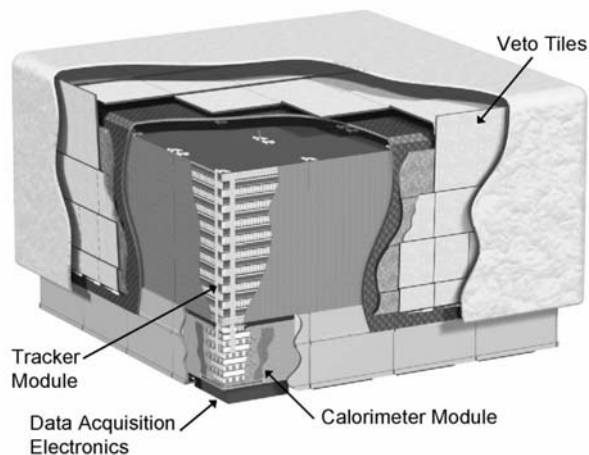

Figure 1. Cutaway view of the LAT instrument, with cooling radiators and mounting hardware omitted on the bottom side.

into 16 “towers,” as illustrated in Figure 1, which are covered by the ACD and a thermal blanket and meteor shield. An aluminum grid supports the detector modules and the data acquisition system and computers, which are located below the calorimeter modules.

Each of the 16 tracker modules is composed of a stack of 19 “trays.” A tray is a stiff, lightweight carbon-composite panel with silicon-strip detectors (SSDs) bonded on both sides, with the strips on top parallel to those on the bottom. The gaps and amount of material between the 16 tracker modules must be minimized to achieve optimal performance of the detector system. Therefore, the front-end electronics [5] are mounted on the sides of the panels. A special “right-angle interconnect” brings the signals and bias currents around the corner of the tray between the silicon strips and the amplifier-discriminator integrated circuit chips.

Each front-end electronics multi-chip module (MCM) supports the readout of 1536 silicon strips. It consists of a single printed wiring board (PWB) upon which are mounted 24 64-channel amplifier-discriminator ASICs, two digital readout-controller ASICs, the right-angle interconnect, numerous passive components, and two nano-connectors. See Figure 2 for a photograph of one end of an MCM mounted on a tray. Each nano-connector plugs into a long flex-circuit cable, each of which interfaces 9 MCMs to the Tower Electronics Module (TEM), a custom-design data acquisition module located below the calorimeter.

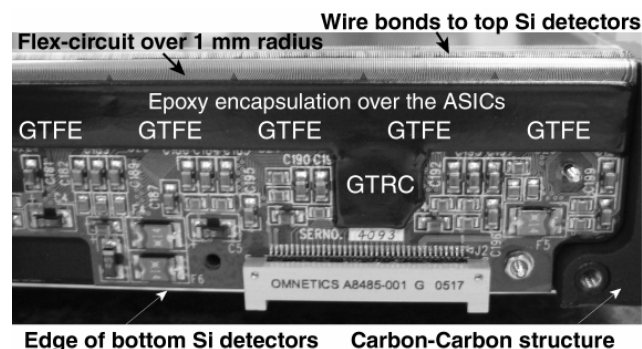

Figure 2. Almost one fourth of a tracker front-end readout module, shown mounted on a tray and wire bonded to the top layers of silicon strip detectors.

In total, the tracker front-end electronics has 884,736 amplifier channels on 576 MCMs, all of which operates on a total power of 160 W. Design and fabrication of this system encompasses the author's direct experience with space hardware. For the purpose of this report, input was also obtained from two engineers at SLAC who worked on the LAT data acquisition electronics (DAQ). Figure 3 shows the DAQ modules mounted and cabled on the back side of the LAT. The 16 TEM modules are installed just under the visible boxes, which include the 3 Event Processing Units (EPU), 2 Power Distribution Units (PDU), 2 Spacecraft Interface Units (SIU), 2 Global-electronics, ACD, and Signal-distribution Units (GASU), and 5 Harness Interconnect Boxes (HIB). The EPUs and SIUs are nearly identical, with each consisting mainly of a radiation-hardened computer (BAE RAD750).

2. DESIGN CONSTRAINTS

Instruments intended for operation in space must satisfy several design constraints that are unfamiliar to physicists working on ground-based experiments but are nonetheless fairly obvious. First of all, power is generally in very short supply. It is difficult to generate, and the waste heat is just as hard to get rid of. One is unlikely to have more than the order of a kilowatt allocated to the entire instrument. In the case of the LAT, the power allocation is only 650 W. That might seem to rule out million-channel particle-physics detectors, but modern CMOS IC technology makes instruments like the LAT possible.

In addition, one has to count on 20% to 30% of the 28 V DC power delivered to the instrument being used up in the conditioning needed to provide lower-voltage, high-quality power to the sensitive electronics. The 20% figure can be achieved if, as in the case of the LAT, synchronous rectification is used. It can make a significant difference for the low-voltage supplies demanded by systems like the tracker (2.65 V and 1.5 V), but the vendors supplying power supplies for space-based use still tend to be behind

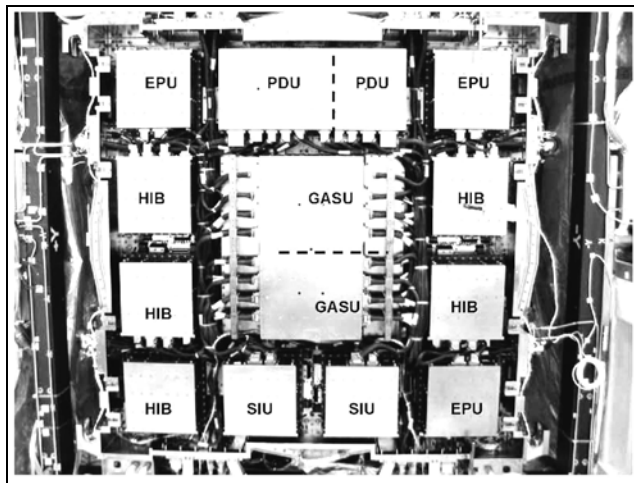

Figure 3. View of the back side of the LAT, showing the data acquisition modules and cabling. Behind the visible set of modules are 16 TEM modules, one for each tower.

the technology curve in this respect and use simpler diode rectifiers.

As already mentioned, radiating the waste heat into space can be a challenge, but one also has to design a way to get the heat from the electronics to the radiators. Passive cooling paths are greatly preferred, and if necessary they can be aided by constant-conduction heat pipes, as used by the LAT in the aluminum grid. The tracker conducts heat through carbon-composite materials, with the final thermal connection to the grid made by copper straps. Significant engineering was needed to ensure that the temperature rise up a tower will not be too great and to ensure that the joints will be sufficiently tight. Even though your piece of the project may be electronics, be sure to plan for adequate mechanical engineering.

Space-based experiments have to be designed to survive a rough ride into orbit and also to survive possible temperature extremes in vacuum. Therefore, vibration, acoustic, and thermal-vacuum testing are required for all assemblies. In fact, the worst environments in a successful mission will be encountered during ground-based testing. Once in orbit, a system like the tracker will have a very benign environment in many respects: no moisture, stable temperature (as long as the power doesn't go out), little vibration, no rats to chew on wires, and no physicists trying to "improve" the hardware.

Extensive testing for electromagnetic interference, radiated and conducted, is required in order to ensure not only that the instrument will work in a less-than-ideal environment but also to ensure that it will not interfere with the spacecraft radios and navigation systems.

Radiation in low-Earth orbit is very low compared with accelerator interaction regions. The lifetime exposure of the tracker will be only several kilorads. Total dose testing was required, but it had essentially no effect on the electronics and only a small impact on detector leakage current. Missions that go into polar orbits or venture outside the protection of the Earth's magnetosphere have to be more concerned with total dose. For the LAT, single-event radiation effects are of greater concern, especially for the data-acquisition computers.

Reliability is obviously a great concern for space-based experiments. The designers should plan on zero hardware maintenance once a subsystem is delivered to the integration-and-test crew. However, systems in the centers of modern accelerator experiments also must be designed to be maintenance free, so high reliability is not a completely foreign concept to particle physicists.

Redundancy is an obvious design approach to avoid catastrophic failures. However, if overdone it can become prohibitively expensive to implement the redundant systems and ensure that they can take over if and when needed. Therefore, redundancy cannot generally be substituted for quality. In fact, we found that NASA quality engineers do not easily accept redundancy as an argument for cutting corners on quality to save time or costs.

3. HIGH TECHNOLOGY

In general, NASA appears to be very conservative about the use of new technologies. By far the easiest way to get any device approved for use in a space-based instrument is to show that it has “heritage” in terms of previous use in space in a similar application or environment. Therefore, if there is no compelling reason to use the latest high-tech widget, then by all means don’t do it. However, this logic inevitably results in high inertia for application of new technologies in space, and as a result, many space technologies look primitive by commercial, or even military, standards.

Even though a specific technology may have some space-flight heritage, it won’t necessarily be standardized to be readily used in general space-flight projects. NASA accepted standard solutions are not plentiful and can be severely out of date. For example, MIL-STD-1553, developed in the 1970s, is still the network standard, to be compared with a plethora of high-speed network solutions available in the commercial market for use on the ground. Similarly, the fastest space-qualified computer available is outperformed by a run-of-the-mill personal notebook computer, but carries the price tag of a mainframe. Each LAT BEA RAD750 computer costs close to a quarter million dollars.

Nevertheless, the technology curve in space does get pushed forward steadily by the demands of ever more complex missions. NASA will work with instrument developers to qualify whatever technology is required to meet the scientific objectives.

4. LOW POWER DESIGN

The LAT is a good example of how a large detector system can be built within a severely limited power budget. It relies heavily on CMOS ASICs to keep the power consumption down. That is especially true in the front-end electronics systems, where the number of required chips is large. In fact, each of the 3 detector subsystems includes two ASIC designs, and there are more in the DAQ system.

The tracker, for example, employs 13,824 mixed-mode chips, each with 64 amplifier channels, plus 1152 digital readout-controller chips. The front-end electronics design evolved from that of the BaBar SVT electronics [6], but with a far greater emphasis on power consumption. The SVT uses about 4000 μ W per channel, compared with 180 μ W per channel for the tracker. Part of the reduction was realized by using a commercial CMOS process, instead of a specialized radiation-hardened process. Other reductions were achieved by reducing the clock rate from 60 MHz to 20 MHz, increasing the detector thickness from 300 μ m to 400 μ m to boost the signal, measuring time-over-threshold only on the trigger signal (OR of all channels in a layer) instead of on every channel, and increasing the shaping time constant. Also, the amplifier chain was kept as simple as possible, with simple RC/CR

shaping, and the voltage was lowered from the nominal 3.3 V of the process to 2.65 V.

In general, no new technological tricks were employed to keep the power consumption down. Instead, a well-proven commercial CMOS process was used, and the design was carefully optimized to fit the mission requirements with no superfluous features. That could not have been achieved without the use of custom-designed IC chips.

5. PARTS AND MATERIALS

We made the mistake at the time of the LAT proposal to assume that we could avoid paying for high-reliability parts for the tracker subsystem front-end electronics. The system consists of hundreds of silicon-strip layers, and parts of or all of many layers could be lost without drastically impairing the capabilities of the telescope. Nevertheless, in the end NASA required us to use expensive space-qualified parts throughout, and any other NASA project should expect the same.

Unfortunately, there is a limited choice of such parts. Lists are maintained at <http://nepp.nasa.gov/npsl/> and <http://www.dsccl.dla.mil/>. The situation is okay for chip resistors and capacitors. However, designers need to keep in mind that NASA overstress requirements will result in much less capacitance for a given package size. Also, the resistors packages are 0505 size, which falls somewhere in between the commercial 0603 and 0805 sizes. One tends to prototype with easily obtained commercial parts, so it is important to plan in advance for the migration to the high-reliability parts in order not to invalidate the prototype work.

On the other hand, the list of qualified microcircuits is relatively new, very small, and a very far cry from what one is accustomed to in the commercial world. Many commercial parts can be used, but then the user is faced with the task of qualifying them for the particular use.

There are two major drawbacks to the space-qualified parts. First, they are expensive. For example, the tracker group paid \$0.78 per 100-ohm 0505 SMT chip resistor, while a similar 0805 commercial part purchased in similar quantity would cost around \$0.02 each. Second, they have a long lead time. Planners should count on a minimum of 12 weeks, but up to 26 weeks is possible. In an emergency, small quantities of common parts can sometimes be found, with NASA’s help, on short notice.

One should not assume, however, that all of that expense guarantees the highest quality part! In fact, modern commercial manufacturing demands very high quality parts, since poor yield on assemblies is a disaster for the bottom line. However, the commercial model for quality is to engineer it into the manufacturing process, including automated testing and screening. The NASA model relies more on laborious screening of individual parts, plus detailed record keeping, generally designed for very low-volume production.

The NASA approach more and more does not fit the business model of most commercial manufacturers, often leaving one with two alternatives:

- [1] Find a small-volume manufacturer willing to deal with the NASA requirements and paperwork to provide qualified parts.
- [2] Purchase commercial parts from a large-volume manufacturer and qualify them yourself.

Here are a couple of anecdotes from the tracker experience. High-voltage chip capacitors were needed for both the tracker and calorimeter and were not obtainable from the standard lists of qualified parts. We had prototyped with 500 V commercial parts, but rather than try to qualify them ourselves, we went to a small manufacturer who would provide custom qualified parts. The manufacturing process was largely manual and old fashioned and relied on visual inspections. Testing was done manually part by part using a custom setup. The parts were more than 10 times as expensive as the commercial parts, had less capacitance, a larger package size, and a lower rating of 250 V. Worse yet, they ended up having a manufacturing flaw that resulted in high leakage current in the presence of humidity, causing us delays while the lot was remanufactured. In retrospect, we may have been better off trying to qualify the commercial parts.

The tracker also needed resettable fuses (“polyswitches”) to keep potential failures from short circuits from propagating through the system. Such devices had never been flown in space, as far as we could determine. We chose to qualify them ourselves, and the manufacturer (Tycho/Raechem) cooperated by providing all needed information and by incorporating a screening process that included thermal cycles to simulate the effects of a solder reflow oven (since the resistance of the part can permanently change when exposed to high temperature). The parts themselves remained inexpensive, but the LAT project had to devote many man-hours to the process. In fact, a project should count on at least a few FTE man months for each part needing qualification.

One potential hang-up with using many commercial parts is that NASA forbids the use of cadmium, zinc, or pure-tin plating, all of which carry risks of growth of conductive whiskers. In fact, the high-voltage capacitor flaw mentioned above was related to this. The manufacturer originally used forbidden plating and then stripped it off to redo the plating. The stripping process apparently damaged the parts and caused the moisture sensitivity.

6. FPGA

Modern electronics, including the LAT DAQ system, relies more and more on Field Programmable Gate Arrays. Space qualified devices are available, but at a very heavy cost in terms of the ratio of price to performance. The LAT Actel devices cost close to \$5000 for 2000 flip flops (although 10,000 flip-flop devices are now available), to be compared with state-of-the-art commercial devices that

cost less than half as much and include 50,000 flip flops, an embedded processor, and fast serial I/O channels. The space-qualified FPGAs use built-in triplication of the gates to avoid upsets, and they have configuration registers that get permanently burned. Thus they are radiation hard, but one has to be very careful to get the configuration correct the first time.

An alternative approach is to use higher performance parts that are less radiation hard and program the triplication into the configuration. That would still leave the SRAM used for the configuration vulnerable to upsets, but a solution to that is simply to reload the configuration regularly from a protected memory.

In either case, NASA will review the FPGA programs. In the LAT experience, the reviewers were primarily interested in making sure that the power-on resets were foolproof and in enforcing conservative discipline in clocking. In fact, they strongly preferred the use of alternate-edge clocking, which guarantees adequate setup time but chews up more of the limited resources on the chip. We found anyway that only 1 of the 3 clock busses on our chips was reliable enough to use for clocking of shift registers without using alternate-edges.

7. ASIC

The use of ASICs in the LAT raised a lot of eyebrows in NASA. The tracker alone, with almost 15,000 chips, is unprecedented among space missions. In view of that, it is interesting that once the design bugs (our own faults) were worked out, the ASICs were among the most trouble-free parts of the tracker fabrication and test experience. We used the Agilent 0.5 μm , 3-metal process (AMOS14), which was purchased through MOSIS and consistently achieved high yield (>90%) on all lots. MOSIS absolutely would not provide any additional quality-assurance (QA) certifications or modified procedures beyond their normal practice in order to accommodate LAT or NASA QA desires. Also, there was no possibility of source inspections, for example, at Agilent, with whom we had no direct communications. Nevertheless, once we produced a written procurement specification outlining nothing more than the normal procedure of working through MOSIS, including the normal test procedures that MOSIS executes on all wafer runs, the project quality engineers were satisfied. In fact, the MOSIS/Agilent quality turned out to be impeccable in terms of yield and uniformity.

We had to demonstrate that the ASICs were sufficiently radiation hard. Our tests included total dose from a ^{60}Co source and single-event effects from heavy-ion accelerators [8]. The total dose was low enough not to cause any noticeable change in the electronics. Single-event latch-up was never observed in any of the heavy-ion tests, and the single-event upset rate was negligible from the point of view of tracker operations. In fact, we designed the configuration registers of the ASICs to be resistant to upset [9], but even without that hardening the upset rate would be negligible. NASA engineers worked closely with us throughout this testing.

Other qualification tests were much more relevant to the IC packaging, or in the case of the tracker the chip-on-board assembly, than to the ICs themselves, which are inherently very robust with respect to vibration and temperature. NASA is very cautious about PEMs (plastic encapsulated microcircuits), but more and more there is no alternative and one simply has to subject them to a battery of qualification and acceptance tests, particularly temperature and humidity.

The tracker qualification and acceptance tests were done at the level of the printed circuit board, to which the ASICs were glued and wire bonded. Vibration and vacuum never caused any problems, but temperature cycles uncovered problems with adhesives, especially the epoxy encapsulation of the chips and wire bonds and the bonding of the flexible circuit around the corner of the board, which formed the interconnect between chips and detectors.

8. PRINTED CIRCUIT BOARDS

In contrast to the ASIC manufacturing, printed circuit board manufacturing had many problems throughout the project, often due to poor vendor performance but in many cases exacerbated by our own design choices. Many of the problems would never have surfaced in a ground-based project, but NASA has very strict qualify requirements. They base their quality control very heavily on coupon testing, and in our experience, they insisted on testing additional coupons themselves instead of relying on the manufacturer's tests. And in numerous cases we had panels rejected by NASA that the manufacturer had passed.

NASA requires a minimum of 0.002" annular ring on every pad around 100% of the circumference of each via, with zero voids in the plating connecting the pad to the barrel. Manufacturers easily get into trouble with such requirements if one designs to their minimum pad size, especially if the board is large. In the tracker experience, a significant number of MCM boards were rejected by NASA coupon testing. In some cases the lag time for testing the coupons could not be accommodated, and we ended up building complete assemblies at risk, some of which had to be discarded when coupon test results came back.

The tracker group had even more severe problems with manufacturing of the flexible-circuit cables used to interface the MCMs with the DAQ electronics [10]. The cables were so long (about 1 m) that both manufacturers had difficulties keeping the pads aligned across all 4 layers, while still satisfying the NASA requirements. Solving those problems greatly increased the cost and caused problematic delays, most of which could have been saved had the design been made more conservative at the outset. Those issues often have to be confronted early, however, because a more conservative design would have impacted the cable width, which then would have greatly impacted the overall mechanical design of the tracker.

We found at the beginning of the project that NASA was generally very leery of flexible circuits. We discounted their concerns initially, but our experience probably only reinforced their views on the technology.

9. CONNECTORS AND CABLES

Just as in ground-based experiments, connectors and cables are items that usually turn out to be much more trouble and more expensive than anticipated. Therefore, adequate attention must be paid to them from the beginning. A full-fidelity cabling mockup is highly recommended.

One must be prepared in a space-based experiment to pay more for connectors and cables than what is customary on the ground. Mated connectors pairs will cost at least \$100 each, and cables assemblies are typically \$2000 each or more, when all costs are accounted for. Circular connectors are the most rugged and reliable, if there is space for them. In the case of the tracker, however, we had to use mostly nano-connectors, which are non-standard and for which we had to deal with numerous manufacturing and handling problems.

NASA requires formal safe-to-mate tests on all connectors that are in flight hardware or connect to flight hardware, each time the connectors are mated. Those tests involve inspection of the connectors themselves and also testing of the electronics to which the connectors are attached.

Despite rumors that we heard early on in the LAT project, there is no absolute NASA limit on the number of mate/demate cycles for connectors in flight hardware. However, in general it is wise to keep the number of cycles as low as possible, so connector savers are recommended to be used up until the final integration of the electronics module. That essentially doubled the cost for connectors in the tracker subsystem, for example. In any case, all mates and demates must be logged for flight connectors.

10. MANUFACTURING AND ASSEMBLY

The following are some common-sense recommendations for achieving success in the manufacturing and assembly processes. First, be sure as early in the game as possible that the electronics design is manufacturable to NASA standards, especially if high-volume production is anticipated. In fact, historically space hardware has been very low-volume production, but projects like the tracker involve hundreds of electronics modules instead of just one board and a few spares. It can be easy to make a prototype assembly work, only to find out too late that the design is not suitable for manufacturing. At the very least, make sure that the prototypes get subjected to the full suite of QA tests and procedure to which the production modules will be subjected.

It is important to have a good manufacturing engineer, with space hardware experience, involved in the project as

early as possible. The tracker program suffered from going too far with the design and prototyping effort before such an engineer was available. And even then, the tracker program had to share an engineer with the rest of the LAT project, when he could have been used full time on the tracker for a year or two.

Similarly, an IEEE parts engineer is needed in the program as early as possible. The LAT had to share an engineer between the west and east coasts, and many problems could have been avoided had a parts engineer been dedicated to the SLAC efforts.

For assembly of electronics modules, manufacturers of today generally are geared up to work to IPC specs, not to the older NASA or MIL specs. In principle, NASA is migrating to IPC, but it definitely has not happened yet. In practice, we had to supplement the IPC specs with a few more stringent NASA-specific requirements and then get both vendor and NASA buy-in.

Vendors with space-hardware experience and a good track record are obviously to be preferred, but neither that nor the specification documents are any guarantee of getting good results. Companies can lose relevant experience rapidly as people retire or move on, so even a good track record might be misleading. Whatever the case, constant oversight is important.

NASA will probably want their quality engineers to survey the vendor. That can be useful, and one should make the best of it. The NASA engineers are acutely aware of details that have burned them before. To take an anecdote from the tracker experience, the MCM assembly vendor was using Kapton masking tape to protect the wire-bonding surface during several manufacturing steps. A NASA quality engineer picked up a roll of the tape during a walk-through and immediately recognized that it used a silicone adhesive, something forbidden by NASA. The resulting silicone contamination explained a problem that we were having with delamination of the encapsulation material.

It is highly recommended to keep a project engineer or physicist, preferably somebody with a vested interest in the success of the project, on the assembly floor throughout the production. In our experience, the vendor QA personnel were kept busy with paperwork rather than being on the floor observing the actual manufacturing procedures. The written travelers, procedures, and other paperwork have a lot of value, but they do not by any means guarantee that the assembly work is being done correctly.

Project personnel generally must do the final tests and inspections of the assemblies. If it is possible, do that at the vendor's facilities, but in any case keep the lag time minimal, in order that problems can be correctly shortly after they occur.

11. CONCLUSION

A space-based detector system will have a significantly greater cost than the same object build for use in a ground-based facility, partially due to the high cost of qualified

parts and the additional QA requirements. Those costs need to be realistically taken into account at proposal time, or else the lack of funds early on will compromise the project such that even greater costs are incurred later on while working in crisis mode. Unfortunately, this wisdom typically has to work against the tendency to low-ball the proposal in order to get initial approval for the project.

Even with adequate funding, however, you may well feel frustrated by lack of explicit guidelines as to what NASA requires in all circumstances. In fact, different people or groups within the organization will often provide different and contradictory advice. Nevertheless, a common-sense approach will go very far toward getting you through the bureaucracy if you take seriously a few more points:

- [1] Even though NASA is by no means ISO-9000, and so far does not force projects to be ISO-9000, documentation of *your* requirements, *your* design, *your* plans and procedures, *your* assembly-by-assembly manufacturing experience, and *your* test results that validate your product is key to winning them over. You will have to demonstrate adherence to some mission assurance requirements that NASA imposes explicitly in a document (or else obtain waivers for specific requirements) but the main objective is for you to convince first yourself and then NASA that the instrument will succeed.
- [2] Recognize that NASA QA will often seem inflexible and sometimes seemingly make mountains of molehills, but at the same time that they have a wealth of valuable experience gained the hard way in many previous space missions.
- [3] Plan for success in any test that in any way goes on the record. Officially recognized tests cannot be used to “try out” an idea to see if it works, even if the requirement to carry out the test came from you rather than NASA. The price of a test failure is likely to be severe delays while you get more “help” than you could ever have wished for.

The tracker and the LAT instrument as a whole demonstrate the feasibility of a very complex, ground-breaking instrument being built by groups with, for the most part, no space experience. This achievement was accomplished only by working very closely with NASA. The instrument works impressively well, but there were overruns and delays, with many lessons learned the hard way. Hopefully this report will help some others avoid a few pitfalls in future missions.

Acknowledgments

The author wishes to thank David Nelson and Eric Suskind for helpful discussions and input on the non-tracker aspects of the LAT electronics fabrication.

Work supported in part by Department of Energy contract DE-AC02-76SF00515 and grant 22428-443410.

References

- [1] W.B. Atwood, “GLAST: applying silicon strip detector technology to the detection of gamma rays in space,” *Nucl. Instrum. Meth...A*, vol. 342, p. 302, 1994.
- [2] N. Gehrels and P. Michelson, “GLAST: the next-generation high energy gamma-ray astronomy mission,” *Astropart. Phys.*, vol 11, p. 277, 1999.
- [3] D.J. Thompson, et al. “Calibration of the Energetic Gamma-Ray Experiment (EGRET) for the Compton Gamma-ray Observatory,” *ApJ Suppl.*, vol. 86, pp. 629–656, June 1993.
- [4] W.B. Atwood, *et al.*, “The silicon tracker/converter for the Gamma-ray Large Area Space Telescope,” *Nucl. Instrum. Meth. A*, vol. 435, p. 224, 1999.
- [5] Luca Baldini *et al.*, “The silicon tracker readout electronics of the gamma-ray large area space telescope,” *IEEE Trans. Nucl. Sci.*, vol. 53, pp. 466–473, Apr. 2006.
- [6] I. Kipnis, *et al.*, “A Time-Over-Threshold Machine: the readout integrated circuit for the BaBar Silicon Vertex Tracker,” *IEEE Trans. Nucl. Sci.*, vol 44, p. 289, 1997.
- [7] MOSIS Integrated Circuit Fabrication Service, USC Information Sciences Institute, 4676 Admiralty Way, Marina del Rey, CA 90292-6695.
- [8] R. Rando *et al.*, “Radiation testing of GLAST LAT tracker ASICs,” *IEEE Trans. Nucl. Sci.*, vol. 51, p 1067, 2004.
- [9] L.R. Rockett, “An SEU-hardened CMOS data latch design,” *IEEE Trans. Nucl. Sci.*, vol. 35, pp. 1682–1687, Dec. 1988.
- [10] Luca Baldini *et al.*, “Fabrication of the GLAST Silicon Tracker Readout Electronics,” submitted to *IEEE Trans. Nucl. Sci.*, SLAC-PUB-11715, Feb 2006.