

PEP-II RF SYSTEM OPERATION AND PERFORMANCE*

P. McIntosh, J. Fox, D. Teytelman and D. Van Winkle, SLAC, Menlo Park, CA, USA

Abstract

The Low Energy Ring (LER) and High Energy Ring (HER) RF systems have operated now on PEP-II since July 1998 and have assisted in breaking all design luminosity records back in June 2001. Luminosity on PEP-II has steadily increased since then as a consequence of larger e^+ and e^- beam currents being accumulated. This has meant that the RF systems have inevitably been driven harder, not only to achieve these higher stored beam currents, but also to reliably keep the beams circulating whilst at the same time minimizing the number of aborts due to RF system faults. This paper details the current PEP-II RF system configurations for both rings, as well as future upgrade plans spanning the next 3-5 years. Limitations of the current RF system configurations are presented, highlighting improvement projects which will target specific areas within the RF systems to ensure that adequate operating overheads are maintained and reliable operation is assured.

- LLRF system module redesigns have been performed to improve dynamic response, provide additional diagnostics, whilst minimizing LLRF system aborts.
- By improving the response time of the feedback systems, control of the fundamental cavity impedance growth rates can increase the instability thresholds and larger beam currents can be stored in the HER.
- The LLRF feedback systems operate optimally when the klystrons function in an un-saturated (or linear) regime. At high klystron powers on PEP-II, this can be difficult to achieve and so a feedback control for linearizing the response of the klystron at high powers is being investigated.

These primary system improvements are detailed along with other adaptations that are currently being investigated and/or implemented for the PEP-II RF systems.

INTRODUCTION

PEP-II presently holds the world record for beam currents stored in a circular accelerator. Positron beam currents in the 3.1 GeV LER have now reached 2.4 Amperes and are projected to increase further over the coming years to 4.5 Amperes. Electron beam currents in the 9 GeV HER are also planned to increase over the same timeframe from the present level of 1.44 Amperes to 2 Amperes [1]. The operational stability of these intense beams will become increasingly more difficult to maintain. Already at current operating levels, the phase and amplitude stability margins of the RF feedback loops are becoming compressed and longitudinal instabilities (due to the fundamental cavity impedance growth rates) are making stable operation more difficult to achieve. Techniques to overcome these limitations are being investigated and implemented:

PUSHING FOR HIGHER LUMINOSITY

The design luminosity for PEP-II of $3.0 \times 10^{33} \text{ cm}^{-2} \text{ s}^{-1}$ was successfully surpassed in July 2001 reaching $3.399 \times 10^{33} \text{ cm}^{-2} \text{ s}^{-1}$ with a compliment of 3 x LER and 5 x HER RF stations. Since that time, the peak luminosity on PEP-II has increased substantially to $9.015 \times 10^{33} \text{ cm}^{-2} \text{ s}^{-1}$ with 3 x LER and 8 x HER RF stations. Beam currents have also increased over this 3 year period, from 1.62 A in the LER and 0.9 A in the HER to 2.4 A and 1.44 A respectively. The average RF power requirements for each station have notably increased as a consequence of these high intensity beams and as Luminosity is pushed further, more RF stations will be required over the coming years. Table 1 shows chronologically how the RF system requirements have progressed and how they are predicted to evolve in order to achieve the proposed increases in luminosity for PEP-II.

Table 1 PEP-II RF System Characteristics

RF Parameters	HER					LER				
	Jul 2001	Jul 2004	Jul 2005	Jul 2006	Optimum 2006	Jul 2001	Jul 2004	Jul 2005	Jul 2006	Optimum 2006
RF Voltage/Ring (MV)	10.6	16	16.7	17.5	19.5	3.5	3.8	5.05	6.8	8.5
Number of Klystrons	5	8	9	10	10	3	3	4	5	5
Number of Cavities	20	26	26	26	26	6	6	8	10	10
Average Gap Voltage/Cavity (kV)	530	615	642	673	750	583	633	631	680	850
Average Dissipated Power/Cavity (kW)	38	51	55	61	75	46	54	53	62	97
Average Beam Power/Cavity (kW)	161	200	219	233	279	186	282	261	264	340
Average Total RF Power/Cavity (kW)	199	250	275	294	354	231	336	314	326	437
Average Klystron Power (kW)	847	858	835	805	966	490	740	683	695	914
Beam Current (A)	0.9	1.44	1.58	1.68	2	1.62	2.4	2.91	3.6	4.5
Luminosity ($10^{33} \text{ cm}^{-2} \text{ s}^{-1}$)	3.399	9.015	12	15.8	23.5	3.399	9.015	12	15.8	23.5

* Work supported by Department of Energy contract DE--AC02--76SF00515

RF SYSTEM OPERATION

The fundamental requirement for the PEP-II LLRF system is the suppression of longitudinal coupled bunch oscillations caused by the interaction of the beam with the accelerating mode of the cavities [2]. Three feedback loops and one feed-forward function are used, with the aim of reducing the fundamental cavity impedance as seen by the beam (see Figure 1).

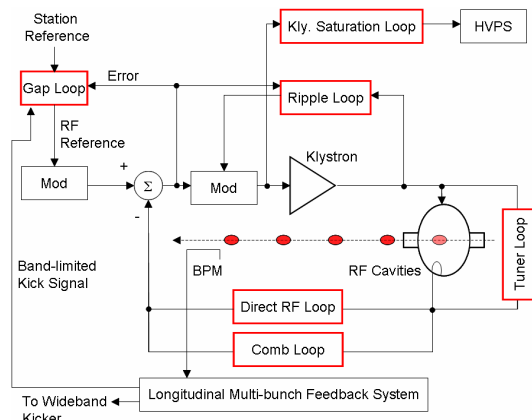

Figure 1 LLRF Feedback Controls

A **Direct RF loop** re-injects a portion of the cavity field signal back into the klystron drive to accomplish a 15 dB reduction of the drive impedance. A short group delay is necessary to provide 800kHz bandwidths for this loop driving the requirement for a 150 nsec group delay for the klystron. A **Comb RF loop** with a digital IIR filter provides an additional 17 dB impedance reduction at the synchrotron sidebands adjacent to each revolution harmonic of the beam (see Figure 2).

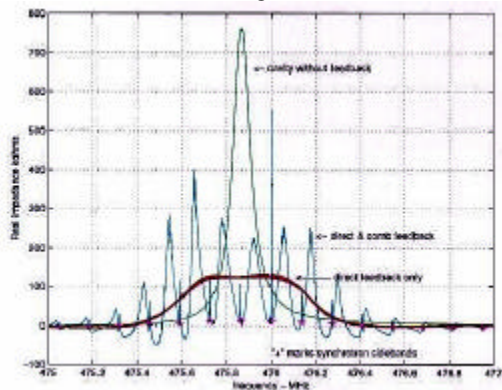

Figure 2 Measured Cavity Feedback Response

A third loop processes the low frequency components of the longitudinal feedback (LFB) system and applies a powerful kick to the beam through the RF system. This causes additional damping to the coupled bunch modes within the cavity bandwidth. To prevent saturating the klystron during the ion-clearing gap in the beam, an adaptive feed-forward **Gap loop** removes the effect of the gap in the klystron drive signal. A **Ripple loop** reduces

the effects of the power supply ripple and keeps the phase length of the klystron constant when the high voltage is varied. The **Tuner loop** then keeps the cavity on resonance and adjusts the detuning related to beam loading and additional loops like the **Klystron Saturation loop** are implemented in EPICS control software.

RF SYSTEM IMPROVEMENTS

Operational limitations of the PEP-II RF systems are being identified and solutions initiated, the most prominent of which are currently:

Klystron Saturation

The 11 RF stations currently on PEP-II comprise of 6 x Philips YK1360, 1 x Marconi K3512S and 4 x SLAC BFK 1.2 MW klystrons. When these klystrons operate close to saturation, the output response becomes non-linear. Reducing the drive power to pull them out of saturation also reduces the gain of the klystron, putting more power into the collector. The Philips and Marconi klystrons are not equipped with full-power collectors and are hence limited in terms of how far they can be pulled out of saturation at high powers. The SLAC klystrons however have full-power collectors which allow them to be run in a more linear mode, at much higher powers. As a consequence, we are currently building more SLAC BFK tubes both for installation in the new RF stations and also to replace the now ageing Philips and Marconi tubes.

Single Side-band Comb Filter

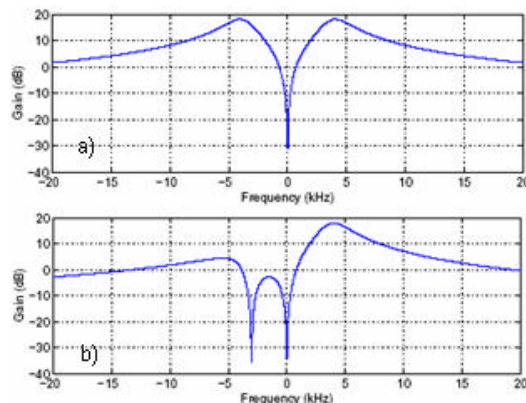

Figure 3 a) Present and b) New Comb Filter Response

The current LLRF comb filter module has a symmetric response about each revolution harmonic. The positive side-band peak reduces the real part of the cavity fundamental impedance which excites the positive eigenmode ($m+1$), whereas the negative side-band peak increases the real part of the impedance for the negative eigenmode ($m-1$). Reshaping of the comb filter to suppress the lower side-band reduces the excitation of the mode $m-1$ resonance (see Figure 3). A development project is underway to manufacture a Version2 comb module which allows for this asymmetric response to be programmed; the first prototype module is expected in early 2005.

VXI Module Thermal drifts

In order to replace obsolete components, improve module response and the on-board diagnostics, several of the LLRF VXI modules have been redesigned in both hardware and firmware. As a consequence, it has been observed most recently that RF station phase drifts in stations equipped with these newer modules have generated a number of beam aborts. Investigations have revealed that the complex multipliers used in the new RF Processor (RFP) modules are more sensitive to temperature variations than their predecessors, inducing station phase drifts causing the klystron output power to oscillate as a function of RFP module temperature. To negate this effect, work is ongoing to improve the temperature cooling of the VXI control racks and also cancel out the drifts with on-board offset electronics.

Low Group Delay Woofer

The residual growth rates of the cavity fundamental mode impedances are managed by the bunch-by-bunch LFB system [3]. A dedicated link between the LFB and RF stations, by means of a low-pass filtered version of the feedback correction signal, phase modulates the station reference, using the RF stations as low-frequency, high-gain actuators - thus the name "woofer". At high beam currents in PEP-II, the residual growth rates reach $1-2 \text{ ms}^{-1}$ nearing the limit of the LFB system. This limit is defined by the minimum group-delay in the feedback channel and the trade-off between optimizing the control of the low modes (via the woofer) and the control of the HOMs via the broadband kicker. In order to extend the control limit a separate feedback channel for the low modes has been developed [4]. This is a digital signal processing element operating at 9.81 MHz rate and sampling the beam motion 72 times per turn. The channel implements individual 14-tap FIR filters for each of the 72 channels creating an effective feedback. The output of this channel is sent to the RF station instead of the low-pass filtered version of the wideband LFB signal. The low group-delay woofer prototype was commissioned in early May 2004 and provided at least a 50% improvement in the achievable feedback damping. This improvement allowed the HER beam currents to be raised from 1380 mA to 1560 mA.

Klystron Linearizer

The LLRF Direct and Comb loop effectiveness is directly related to the small-signal gain of the feedback loops around the klystron. The nominal operating point of the klystron results in a compression of the small-signal gain relative to the large-signal gain, so that the effective impedance driving instabilities may be 5 to 20X larger than a linear klystron would provide. A more linear klystron operating point may not be possible due to collector power limits, or desirable considering the electrical power conversion efficiency of these devices. A klystron linearizer technique is being investigated to equalize the klystron small signal and large signal gains [5]. The central feature of this technique is a feedback loop acting on a wideband amplitude modulator in the

klystron signal path. This circuit acts to distort the input signal so that after the non-linear saturated klystron, the small-signal gain across the klystron is held constant. This technique is currently being evaluated for future use in PEP-II.

RF SYSTEM ABORT STATISTICS 2004

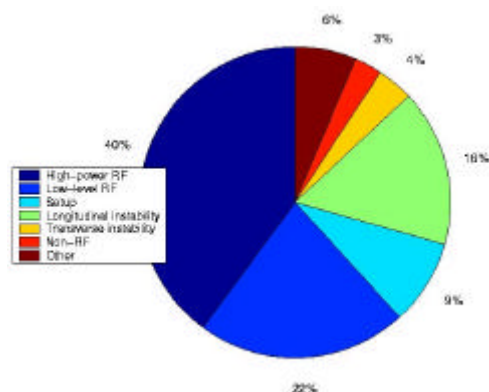

Figure 4 RF System Aborts (Sept 2003 – Jun 2004)

For this current run on PEP-II (since Sept 2003) the RF system abort rate is 3.7 aborts/day, which a marked improvement over the previous run (Sept 2002 – Jul 2003) of 7 aborts/day. Figure 4 shows a categorical breakdown of the aborts for this current run and indicates that high power RF component failures have been the main contributor. These have been primarily cavity arc and vacuum events and HVPS SCR failures. As the RF systems have been pushed harder, it has taken a concerted effort by many people here at SLAC to minimize the number of RF aborts. Problems have also been mitigated wherever possible by redesigning existing hardware and supplementing with new systems to increase both system reliability and feedback operating margins.

ACKNOWLEDGEMENTS

The authors would like to acknowledge the diligent and determined efforts of the PEP-II RF Task Force, who comprise members from SLAC's Accelerator Research A, Electronics and Software, Klystron, and Power Conversion Departments, for the continued success of PEP-II RF system operations.

REFERENCES

- [1] J. Seeman et al, "Results and Plans of the PEP-II B-Factor", these proceedings.
- [2] P. Corredoura et al, "LLRF System Design for the PEP-II B-Factor", PAC'95, Dallas 1995, pp 2672-2674.
- [3] D. Teytelman, "Operation and Performance of the PEP-II Prototype Longitudinal Damping System at the ALS", PAC'95, Dallas 1995, pp 2420-2422.
- [4] J. Fox et al, "Development and Testing of a Low Group Delay Woofer Channel for PEP-II", these proceedings.
- [5] F.E. Terman et al, "Some Notes on Linear and Grid-Modulated Radio-Frequency Amplifiers", Proc. of the IRE, March, 1941.