



SLAC-PUB-10775
SCIPP 2000/01
January 2000

The GLAST Silicon-Strip Tracking System

R.P. Johnson

Santa Cruz Institute for Particle Physics
University of California
Santa Cruz, CA 95064

on behalf of the GLAST Collaboration

Stanford Linear Accelerator Center,
Stanford University, Stanford, CA 94309

Contribution to the 5th Compton Symposium on Gamma-Ray Astronomy:
Celebrating the First 40 Years of Gamma Ray Astronomy,
Portsmouth, NH, 9/15/1999—9/17/1999

The GLAST Silicon-Strip Tracking System

Robert P. Johnson

*Santa Cruz Institute for Particle Physics
University of California at Santa Cruz*

Abstract. The GLAST instrument concept is a gamma-ray pair conversion telescope that uses silicon microstrip detector technology to track the electron-positron pairs resulting from gamma-ray conversions in thin lead foils. A cesium iodide calorimeter following the tracker is used to measure the gamma-ray energy. Silicon strip technology is mature and robust, with an excellent heritage in space science and particle physics. It has many characteristics important for optimal performance of a pair conversion telescope, including high efficiency in thin detector planes, low noise, and excellent resolution and two-track separation. The large size of GLAST and high channel count in the tracker puts demands on the readout technology to operate at very low power, yet with sufficiently low noise occupancy to allow self triggering. A prototype system employing custom-designed ASIC's has been built and tested that meets the design goal of approximately 200 μ W per channel power consumption with a noise occupancy of less than one hit per trigger per 10,000 channels. Detailed design of the full-scale tracker is well advanced, with non-flight prototypes built for all components, and a complete 50,000 channel engineering demonstration tower module is currently under construction and will be tested in particle beams in late 1999. The flight-instrument conceptual design is for a 4 \times 4 array of tower modules with an aperture of 2.9 m² and an effective area of greater than 8000 cm².

OVERVIEW

This paper describes the tracker-converter section of a proposed instrument (1) for the Gamma Large Area Space Telescope mission (2), currently in its formulation phase. GLAST is a gamma-ray pair conversion telescope that operates in much the same way as the EGRET experiment on the Compton Gamma Ray Observatory (3). As a successor to EGRET, however, GLAST is expected to improve upon EGRET's sensitivity to astronomical point sources by factors of 10 to 100. That is accomplished in this design primarily by taking advantage of silicon-strip detector technology developed during the past

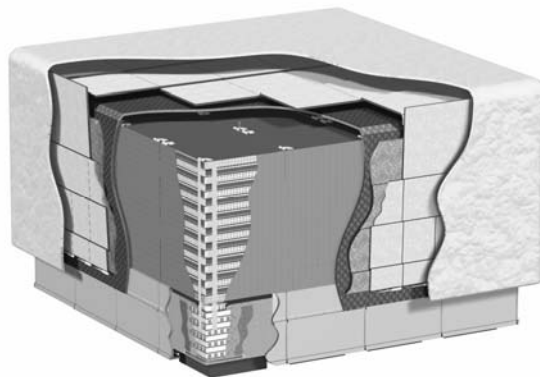

FIGURE 1. Cutaway view of the GLAST instrument, composed of a 4 \times 4 array of tower modules surrounded by a veto shield and thermal blanket.

decade for applications in elementary particle and space physics experiments.

The GLAST detector consists of a square 4×4 array of nearly identical tower modules, as indicated in Fig. 1. Each tower has a scintillator veto counter on the top (and on the sides for the edge towers), followed by a multilayer silicon-strip tracker and, finally, a cesium iodide calorimeter. Each of the tracking layers has two planes of single-sided silicon-strip detectors with strips oriented at 90 degrees with respect to each other. All but the bottom few layers have a thin lead foil preceding the detector planes. The foils convert the incident gamma-ray photons into electron-positron pairs, which are subsequently tracked by the remaining detector layers to determine the photon direction. Finally, the calorimeter absorbs the electrons and thereby measures the photon energy.

Besides providing optimal angular resolution for this type of device, the silicon-strip technology is fast, yielding a system with very little dead time, provides excellent multi-track separation, which is important for pattern recognition and background rejection, and can be made self triggering. The latter two points eliminate the need for a time-of-flight system, such as that used by EGRET for triggering, and thereby result in a very compact instrument with a wide, 2.3 sr fwhm, field of view. The silicon-

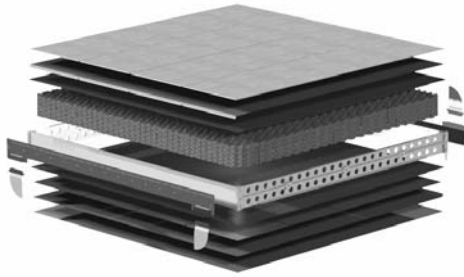

FIGURE 2. Exploded view of a tray.

strip technology is by now well developed, is known to be robust, requires no consumables, such as gas, and operates at a relatively low voltage, compared with spark or drift chambers. It therefore appears to be ideally suited for space applications and, in fact, already has a substantial heritage in space applications. The AMS experiment is a notable example of a large silicon-strip system used in space (4).

TRACKER TOWER MECHANICAL STRUCTURE

The support structure for the silicon-strip detectors must prevent damage to the detectors, electronics, and wire bonds during 10 g static accelerations and random vibrations in excess of 14 g rms. A tracker tower is made up of 19 carbon-composite sandwich structures, called “trays,” each of which supports silicon-strip sensors on both sides and readout electronics on two edges. Figure 2 shows an exploded view of a tray.

Figure 3 shows a view of a single tower, with the

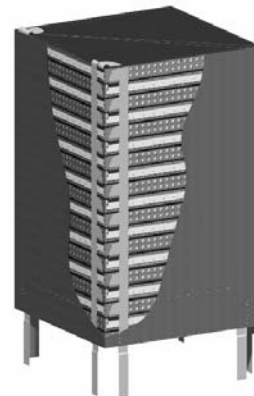

FIGURE 3. Cutaway view of a single tracker tower.

trays stacked up and held in alignment by pins in the four corners. Vectran cables under tension also pass through the corners to hold the stack in compression. Two thin flex-circuit cables on each of the four sides connect the readout electronics to the data acquisition system (DAQ). All four sides are covered by 1.5 mm carbon-fiber walls, which act as shear panels and conduct heat from the electronics to the base of the tower. A complete engineering model of this structure has been fabricated with aluminum tray panel closeouts and subjected to vibration testing in excess of the Delta-II launch vehicle qualification levels without damage or excessive displacement (5). A fully instrumented tray has also been subjected to the same qualification levels with no resulting damage.

SILICON-STRIP READOUT ELECTRONICS

The GLAST instrument design has more than a million silicon-strip channels. Two clear limitations on operating such a system in space are the availability of power for the electronics and the difficulty of dissipating the resulting heat.

Previous silicon-strip systems, designed for operation in ground-based experiments or in space with a significantly smaller number of readout channels, have not needed to contend with such severe power limitations. For those reasons, a major goal of the research and development effort within the GLAST collaboration has been to design and test readout electronics that can meet the signal-to-noise requirements with minimal power dissipation.

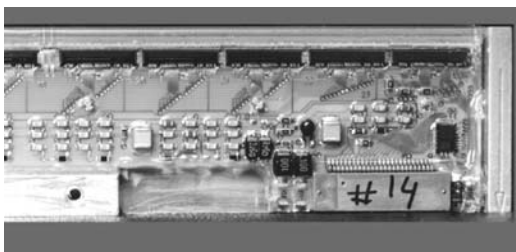

FIGURE 5. Photograph of one end of a completed prototype readout section, mounted on a prototype tray (aluminum closeout).

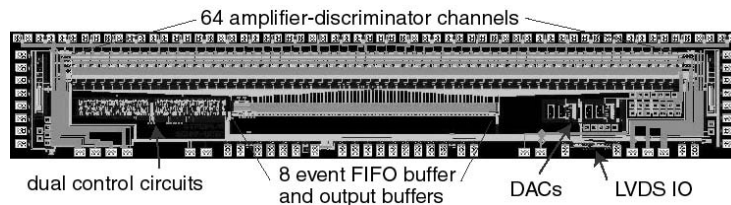

FIGURE 4. Layout of the front-end readout chip.

The readout is based upon the 64-channel CMOS ASIC (GTFE64) illustrated in Fig. 4. The amplifier-discriminator chain, described in (6), operates at a power level of only $140 \mu\text{W}$ per channel, with about $1600 e$ rms noise for a 30-cm strip ($\approx 38 \text{ pF}$), and has been well tested in a silicon-strip system operated in particle beams (7). In the GLAST design 28 chips, plus two digital ASICs, are arranged in a readout section attached to the side of a tray

(Fig. 5). The data and control flow for a set of trays is illustrated in Fig. 7. This novel design provides two redundant data and control paths for each chip, protecting the system from catastrophic single-point failures. The digital ASIC (GTRC) acts as an interface to the DAQ and also formats and buffers the data. The data are delivered to the DAQ in the form of a zero-suppressed hit list. This entire system has been proto-

typed in an engineering model with 32 readout sections and operates with a power consumption of only 203 μW per channel at a 12.5 kHz trigger rate.

The principal trigger of the GLAST instrument is provided by the tracker itself. A logical OR is formed of all channels in each readout section and sent to the DAQ where coincidences between x and y layers in the same tracking plane are detected. If 3 consecutive x,y planes in a tower are in coincidence, then a trigger signal is sent to all 16 towers. The trigger signal latches all discriminator outputs into an 8-event deep FIFO buffer, where the data await a readout command from the DAQ.

SILICON STRIP DETECTORS

The tracker design is based upon single-sided, AC-coupled silicon-strip detectors, with p -type strip implants on n -intrinsic silicon. For good operational stability, polysilicon resistors are used to bias the implants. The baseline design calls for four 9.5-cm square detectors, cut from 6-inch wafers, to be wire bonded into 38-cm “ladders,” with 4 ladders on each face of each tray. The strip pitch is 208 microns, making a total of 448 strips per ladder. More than 200 detectors in this technology have already been procured from Hamamatsu Photonics and tested, with excellent results. The fraction of bad strips is well below 10^{-3} , and the leakage current is typically less than 10 nA/cm^2 .

CONCLUSIONS

The design of the silicon-strip tracker for the GLAST instrument is already well advanced. Completely functional engineering models have been built of all components to verify the technological approach. Recently, a complete tracker tower has been constructed, to be operated in test beams in December 1999. Figure 6 shows a photograph of one of 17 trays of that tower. This development effort has verified that the GLAST detector and electronics requirements can be readily achieved by existing technology and has already solved many engineering and fabrication issues, thus minimizing risks for the flight-instrument development.

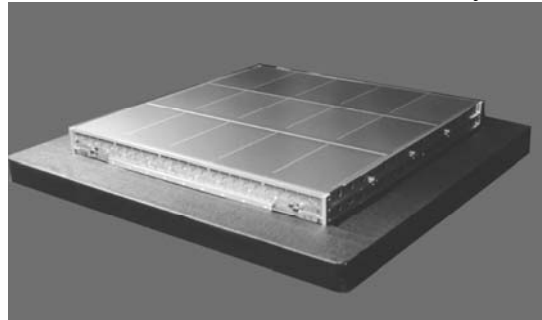

FIGURE 6. A completed prototype tracker tray, with detectors on both top and bottom (not visible) faces. The bottom detectors are read out by electronics on the far side. The heavy base plate that the tray is resting upon is not part of the tower.

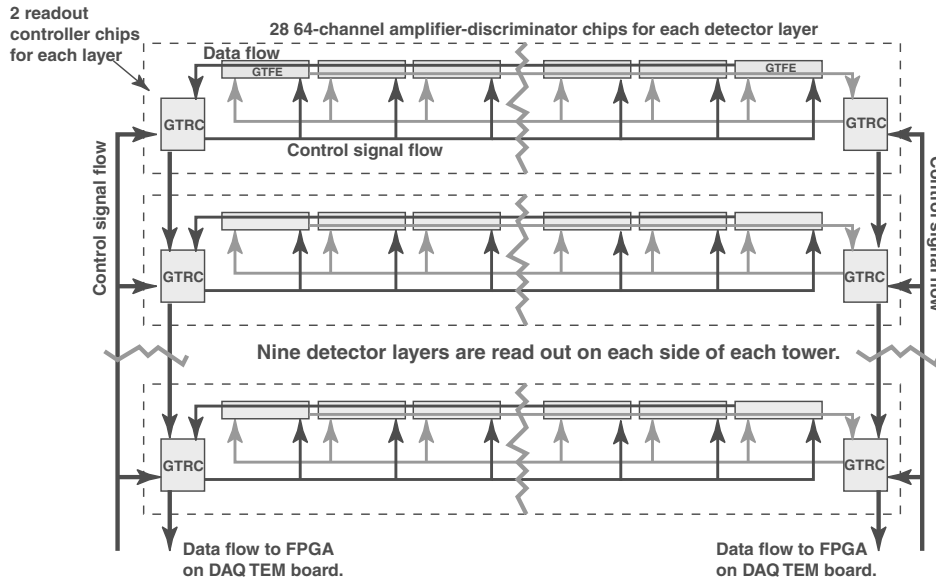

FIGURE 7. Block diagram of the tracker readout electronics. Each pair of redundant cables connecting to the DAQ handles nine readout modules, or one side of one tower.

ACKNOWLEDGMENTS

This work is supported by NASA contract NAS5-98039 and DoE grant DEFG03-92ER40689. I would like to acknowledge the work of all of my colleagues in the GLAST collaboration, in particular those at U.C. Santa Cruz, Stanford Linear Accelerator Center, Tokyo University, Hiroshima University, and Hytec Inc. who have contributed to the silicon-strip tracker hardware design and prototyping work described here.

REFERENCES

1. P. Michelson, *et al.*, *Proc. SPIE* **2806**, 31 (1996).
2. NASA, Office of Space Science, AO 99-OSS-03, *Gamma-Ray Large Area Space Telescope (GLAST), Flight Investigations* (1999).
3. Thompson, D.J., *et al.*, *ApJ Suppl.* **86**, 629 (1993).
4. Pauluzzi, M., *Nucl. Instrum. Meth. A* **383**, 35–43 (1996).
5. Ponslet, E., Ney, S.A., Miller, W.O., *Innovative, Low-Mass, Passively Cooled, All Composite Material Tower Structure for High Resolution Charged Particle Tracking in a Gamma-Ray Space Telescope*, NASA SBIR 97-1 17.01-5179, Phase I Final Report, HYTEC Inc., Los Alamos, NM (1998).
6. Johnson, R.P., *et al.*, *IEEE Trans. Nucl. Sci.* **45**, 927 (1998).
7. Atwood, W.B., *et al.*, to be published in *Nucl. Instrum. Meth. A*, SLAC-PUB-8166 (1999).