

Arnold L. Eldredge, Albert J. Keicher, Marvin Heinz, Richard J. Allyn
 Stanford Linear Accelerator Center
 Stanford University, Stanford, California

Summary

The high vacuum requirements of the Stanford Two-Mile Linear Electron Accelerator plus the radiation produced by electron acceleration have made it necessary to design special vacuum and isolation components. Two of these are special purpose valves capable of operating in a vacuum system at 10^{-8} torr, and the third is a group of quick disconnect couplings used for component installation in the beam switchyard area of the accelerator. One valve is an all-metal, 50-megawatt, S-band microwave valve used to isolate an evacuated rectangular waveguide feed system from exposure to air during the replacement of a klystron drive tube for the accelerator. The valve is built with a remeltable indium seal which provides for leak rates on closure below 24×10^{-8} std. cc He/sec. The second valve is a fast-acting unit that was designed for beam axis application within the disk-loaded waveguide accelerator structure. This valve also has an indium seal that is remotely remeltable and has a measured closing time of nine milliseconds. The group of quick-disconnect couplings, which are 6, 10 and 12-inch pipe sizes, are remotely operable, non-elastomer couplings used in the vacuum chamber system of the beam switchyard. The radiation intensity in this area is sufficient to make elastomer seals impractical and to require that replacement of switchyard components be done quickly and remotely. Indium is also used as a reusable seal for these couplings and can be re-formed mechanically to extend seal life.

RF Waveguide Vacuum Valve

The klystron drive tubes for the two-mile linear accelerator at Stanford are expected to have a normal operating life of 2,000 hours. For the 24-hour-per-day operation envisioned at SLAC this means the replacement of each klystron every 12 weeks. In order to retain the 10^{-8} torr operating vacuum in the accelerator during klystron replacement, two vacuum valves are closed, one in the waveguide system, the other in the vacuum manifold.

The waveguide vacuum valve (Fig. 1) is located at the output of each klystron. The manifold valve is adjacent to a pumpout section which permits the roughing down of the small volume between the klystron window and waveguide valve prior to valving into the main vacuum manifold.

The waveguide valve must operate at the rated output powers of the klystrons (21 MW peak, 24 kW average at 2856 Mc) with low reflection and attenuation. It must also provide a minimum of 50 vacuum tight closures during the course of 10 years, and be capable of operating in a 10^{-8} torr environment.

*Work supported by U.S. Atomic Energy Commission.

This requirement is achieved by using low vapor pressure metals such as stainless steel and copper (for all vacuum-exposed parts).

Figure 2 is a cross-sectional representation of this valve. The microwave structure consists of a resonant iris in the common broadwall of the two adjacent waveguides. The fixed planes of the shorting plates were determined empirically and are the same in all valves. The positions were determined in conjunction with the E-plane, 90° mitre joints such that a bilateral standing wave ratio of 1.08 or less was obtained at the operating frequency. All production units are tuned by squeezing the wall of the input and output waveguide so that the VSWR is reduced to 1.02 or less. Attenuation of the valve is less than 0.1 dB at 2856 Mc/sec.

Continuity of wall currents in the upper waveguide section is achieved through the copper gasket and copper-plated mating surfaces in the backseat region. The miter joints are similar to those described in the references^{1,2} with the exception that a block only partially filling the corner is used (Fig. 1). The ratio of c/d_0 is in good agreement with the curves presented in the references. However, some matching is achieved in conjunction with the shorting planes as mentioned above. No breakdown at these corners was experienced up to peak powers on the order of 60 MW, the limit of our tests.

The vacuum structure of the waveguide valve is composed of the brazed body and plunger subassemblies. The vacuum seal between these subassemblies is made by means of a crush seal joint and a copper gasket. The reusable vacuum seal for klystron replacement is made by forcing the plunger assembly's circular, stepped knife edge into an indium-filled groove concentric with the circular resonant iris in the common broadwall between the two waveguides. The closing force is provided by a lead screw actuator which attaches directly to the plunger assembly. By using concentric machined steps, several sealing edges are achieved. More than 200 closures have been obtained on a single seal (i.e., with leak rates $< 24 \times 10^{-8}$ std cc He/sec) in test units. The indium, however, which has a melting point of 156.6°C , can be remelted readily to provide a virtually infinite seal, by means of heater rods inserted in the valve body. The remelting process requires approximately 1-1/2 hours (including cooldown) and can be performed while the valve is installed and under the accelerator vacuum.

Considerable attention was given to achieve a suitable processing technique for casting good

indium seals, i.e., achieving an indium-stainless steel interface which is free of leak paths and stable under repeated closures. (The technique is being used both for this valve and for the fast-acting valve described below).

The process is composed of two steps; a casting or wetting of the indium into the stainless-steel groove in a dry hydrogen atmosphere, and a remelting of the indium while it is under a vacuum. The first step is performed at temperatures between 750° and 850°C. The dry hydrogen atmosphere reduces the oxides both on the indium and the stainless steel so that a wetting or alloying of the metals can take place. Two runs are made with the first using only a small amount of indium to wet the surfaces of the groove, and with the groove filled to the desired level in the second. This entire process is visually monitored since the length of time required and the temperature are not easily specified parameters. They are affected by the dew point of the hydrogen as well as by the initial conditions of the stainless steel, the indium, and even the furnace.

Upon completion of the furnace processing, the assembly is placed on a vacuum pumped vacuum station where a remelting of the new cast indium is made using external heaters. Vacuum levels on the order of 10^{-5} torr are maintained throughout the remelting, but bursts of gas are detectable as the indium melts. The release of these entrapped gases is sometimes accompanied by sputtering of indium onto the surrounding copper-plated surfaces. This results in etching of these surfaces unless the indium groove is covered with a hood during this first vacuum remelt. By performing this initial vacuum remelt under controllable conditions, subsequent remelting of the seal while the valve is installed will not result in these violent reactions.

Throughout both processing steps, the amount of care and degree of contamination plays an important, but difficult to define, role in the end result. Until the processes involved are more thoroughly understood, these techniques are still in the realm of an art.

All valves are resonant-ring tested at rf powers of 60 MW peak and 24 kW average. In addition, each valve is cycle-tested five times with a maximum allowable leak rate of 1×10^{-8} std cc He/sec. Several units have been operating in test stations for approximately one-half year; each having an excess of 100 closures on a single seal. The rf power attained routinely is on the order of 12 MW peak, 14 kW average.

Fast-Acting Vacuum Valve

A fast-acting vacuum valve for application on the beam axis of the accelerator has been developed. Approximately 30 of these valves are to be installed in the disk-loaded waveguide structure of the accelerator at 330-foot intervals. In the event of vacuum deterioration in any one sector of the accelerator, a sensing device turns the electron beam off and automatically trips the valve at

either end of that sector to isolate the sector from the rest of the accelerator. Because the valves are fast acting, they function to minimize the portions of the accelerator that are exposed to pressure rise. This will reduce contamination and damage to other sectors of the accelerator and the down time for repair. Each valve is required to close in nine milliseconds in providing this protection.

Previous valves used for this kind of protection in an accelerator have usually been valves constructed with non-metallic sealing surfaces and with sliding or rolling parts required to function in a vacuum. The radiation environment that will be present in the two-mile accelerator required that all materials in these valves be radiation resistant. Also, because of the very high vacuum and the long life and reliability requirements, sliding and rolling parts with accompanying rapid wear and galling have been eliminated from this design. Another problem with high speed valves of large travel is severe closure impact resulting in short valve life and reduced reliability.

The valve (Figs. 3 and 4) has a 13/16-inch aperture through which the electron beam passes under normal accelerator operation. The oval disk of the valve has a groove in which a remeltable indium seal is located. When the valve is closed, the knife-edge ring on the tube that forms the aperture indents into the indium to effect the low leak rate seal. With each cycle, the knife-edge ring bites more deeply into the indium. When the valve is in its open position with the oval disk down, a heater in the heater-can can be energized remotely to remelt the indium so that its sealing effect is renewed. The valve can be cycled open and closed approximately 20 to 30 times before it is necessary to remelt the seal. (Under normal circumstances, this is estimated to be well in excess of one year of accelerator operation.) The heater is energized for approximately 10 minutes to melt the indium. Approximately one hour is required to return the valve to operating temperature.

Other components of the valve include the valve spring, which applies a force of 200 pounds, a spring guide, a shaft assembly and bellows, a damping piston and cylinder, latching hooks and a latch bar, an actuating solenoid, and microswitches that provide remote indication of the status of the valve. When the valve receives a signal to close from the vacuum sensing device, its solenoid actuator disengages the latching hooks. The valve spring forces the shaft assembly upward to close the valve by forcing the oval disk into contact with the knife-edge ring. The oval disk is suspended from the shaft by two flexible members. In addition, the disk hinges on two smaller flexible members located at the opposite end of the disk from that shown in Fig. 4. To reduce the impact that occurs between the disk and the ring when this action occurs, the air cylinder and piston at the upper end of the shaft assembly provide deceleration during the final third of the shaft and piston travel.

After the valve has closed and the reasons for vacuum deterioration in the accelerator sector have

been determined and corrected, the sector is again pumped down to 10^{-8} torr, the operating vacuum of the machine. At this time, 90 psi of air pressure is applied through the air tube to the top of the piston in the air cylinder. This depresses the shaft assembly and forces the latch bar down into position to engage the latching hooks. During both the opening and closing cycle both microswitches are actuated to provide remote indication to the Klystron Gallery of the status of the valve.

Some of the design considerations in the development of this valve were that high strength materials be used effectively for the moving parts. Accelerations of 200 to 300 G's occur during operation of the valve. Also, where components such as the latching hooks and the latch bar are subjected to high localized forces at points of engagement, hardened materials had to be used to prolong their life and reliability. The corners of the hooks and the bar were also rounded slightly to prevent excessive stressing of the materials and early failure.

The shaft assembly travels in two bearings and is lubricated by a coating of molybdenum disulfide, a permanent lubricant that is unaffected by the radiation environment. The bellows permits the shaft assembly to operate in air at its upper end and in vacuum within the valve body. Molybdenum disulfide is also used as a permanent lubricant for the piston which operates within the cylinder without seals. The air holes in the side of the cylinder provide release of vacuum damping under the piston during valve closing and also prevent pressure buildup under the piston when it is forced downward to open the valve. An adjustable restriction located in the air fitting on the top of the valve regulates air escape to achieve the desired damping during valve closure.

The valve solenoid is actuated to close the valve through a control circuit in the Klystron Gallery. When vacuum deterioration is detected by a sensing device, it energizes a tripping circuit which causes a charged capacitor to send an actuating pulse to the solenoid.

Experience with the valves to date has shown that the sealing effect was such that the leak rate was less than 10^{-6} std cc He/sec as measured with a mass spectrometer leak detector. In most instances, the rate was less than 1/100th of that rate, and a reliable valve life of more than 1000 cycles has been obtained.

Quick-Disconnect Vacuum Couplings

One of the requirements in the Beam Switchyard (BSY) at SLAC is that the various pieces of equipment along the beam lines be remotely removeable and replaceable. These items in general are magnets, instruments, and drift pipes. They all either contain or are themselves a vacuum chamber. Joining all of these components together into one continuous vacuum system is the function of the quick-disconnect vacuum couplings. These couplings are being built in 6, 10 and 12-inch pipe sizes.

The high radiation level in the Beam Switchyard precludes the use of any elastomers in the couplings. The radio-activity hazard imposes the requirement that the couplings be remotely and rapidly operable. The maximum allowable leakage per joint is 1×10^{-5} std cc He/sec.

To compensate for the lateral and angular misalignment of adjacent pieces of apparatus, the couplings are used in pairs, separated by a bellows as shown in Fig. 5. This arrangement accomplishes several things such as providing an allowance for a 3/16-inch lateral misalignment, 3° angular misalignment, and a 1/4-inch variation in the axial location of apparatus.

All pieces of equipment have a male coupling half on each end of their vacuum chambers. The bellows are welded between two female flange halves. This allows for maximum flexibility in the placement of equipment and also permits inspection of the female flange halves of all joints which are uncoupled regardless of the equipment being removed or installed.

The individual couplings are basically two flanges (Fig. 6), one containing an annular groove filled with indium. The other flange has a circular knife edge of a stepped, triangular cross section protruding from a flat face. The diameter of the circular knife or ridge is the same as the diameter of the groove in the female flange. The two flanges are pulled together forcing the knife edge into the indium, thus making a seal.

The flanges are forced together by two rings which bear against the backs of the flanges at six places equally spaced about the rings. These rings are pulled together by two cam hooks which are operated simultaneously by rotating shafts extending vertically from the cam hooks. As the rings deflect, they distribute the load to the flanges at the six points of contact as shown in Fig. 6. The cam hooks are further spring-loaded by Belleville washers to compensate for the cold flow of the indium and to maintain a nominal loading of 100 lb/inch of seal.

Preliminary testing showed that several closures of a joint could be made without reforming the indium. In three different test runs, more than 50 closures were made without exceeding a leakage rate of 1×10^{-5} std cc He/sec. The leakage rate diminished for the first few days of closure, and, in several instances, was an immeasurable amount. Further evaluation testing is in progress.

References

1. Theodore Moreno, Microwave Transmission Design Data, (Dover Publications, Inc., New York, N.Y., 1948); p. 168
2. Microwave Transmission Circuits, (George L. Ragan, ed.) M.I.T. Radiation Laboratory Series, Vol. 9, p. 207

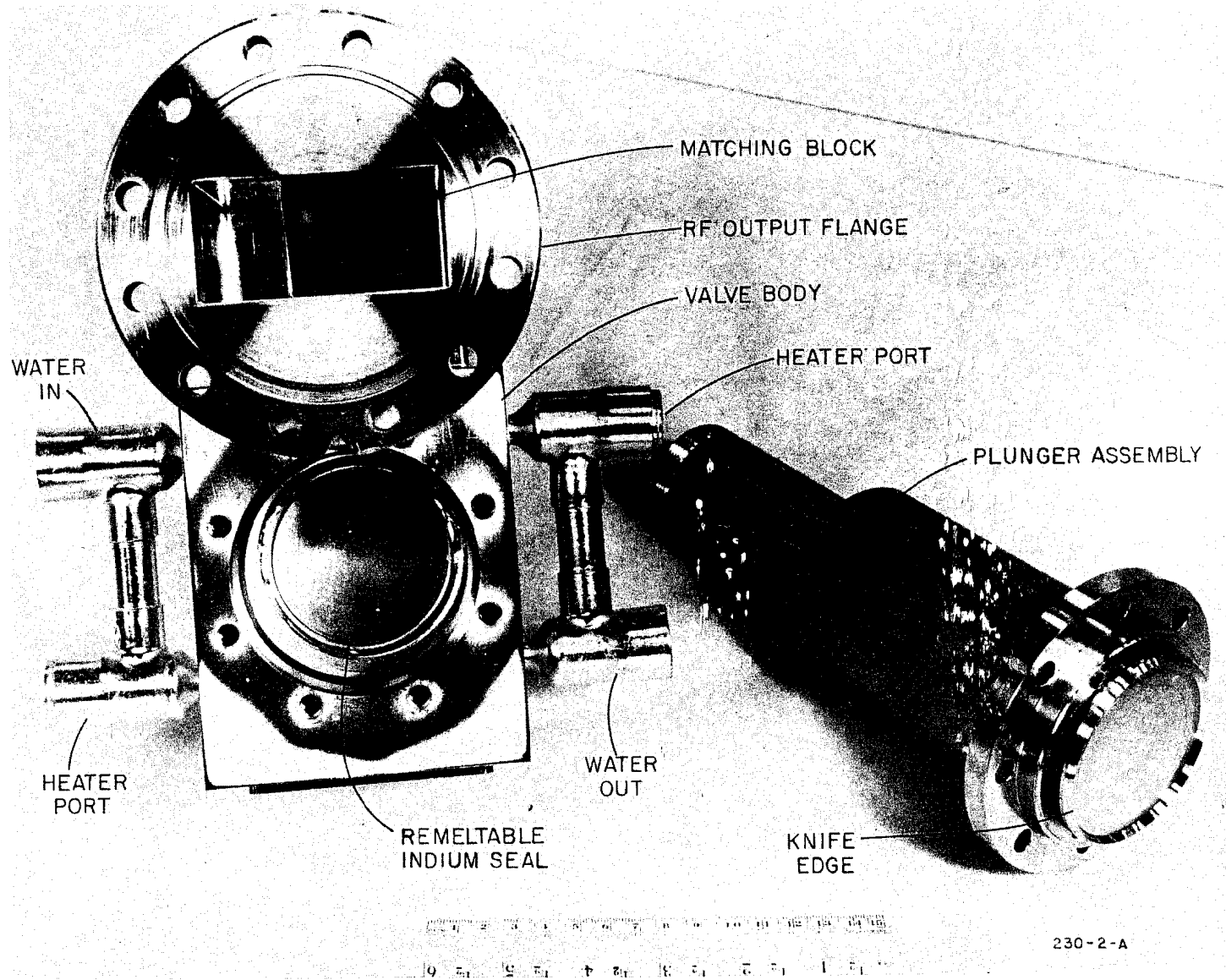

FIG. 1 - RF VACUUM VALVE, PARTIALLY DISASSEMBLED

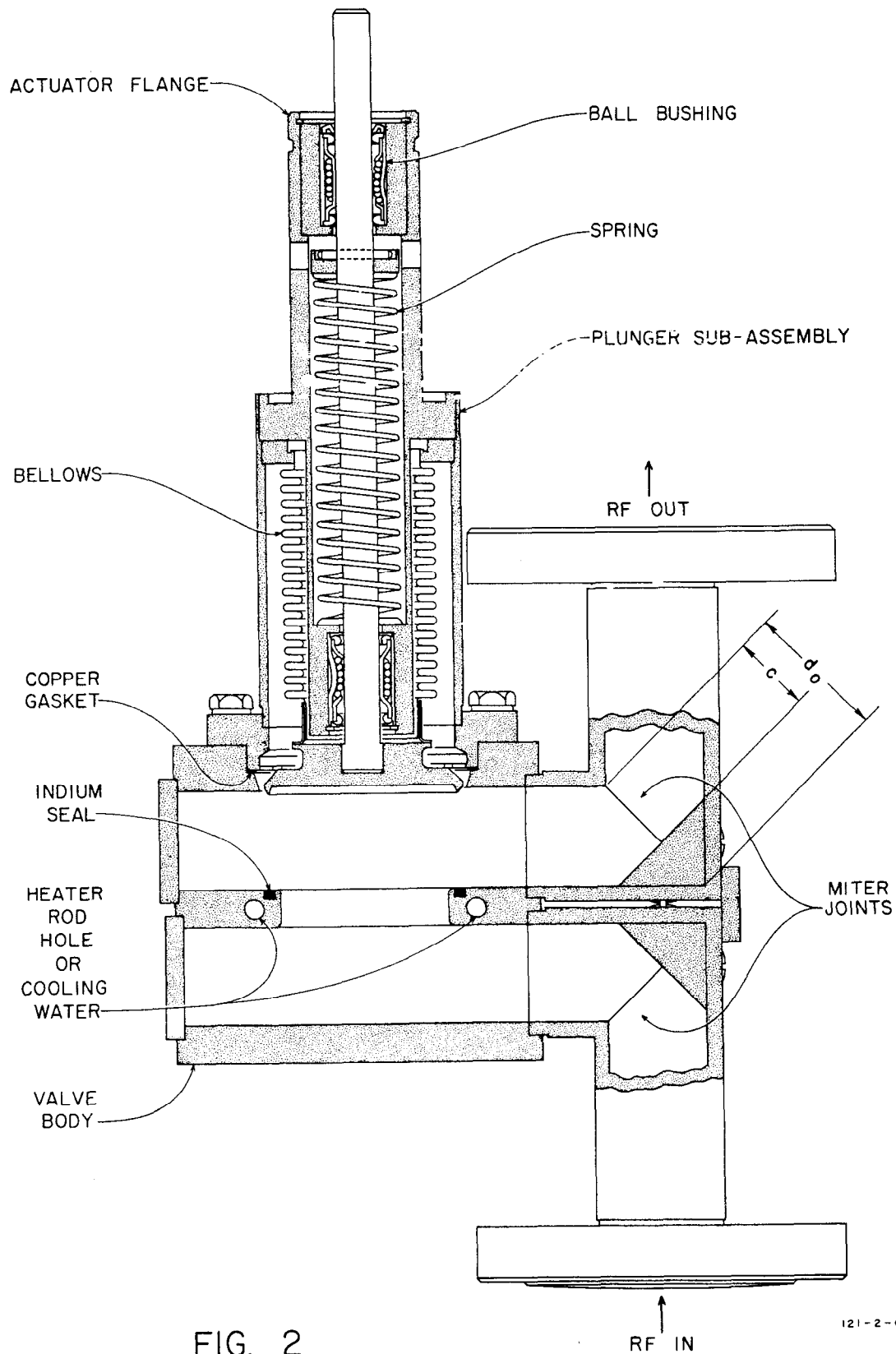
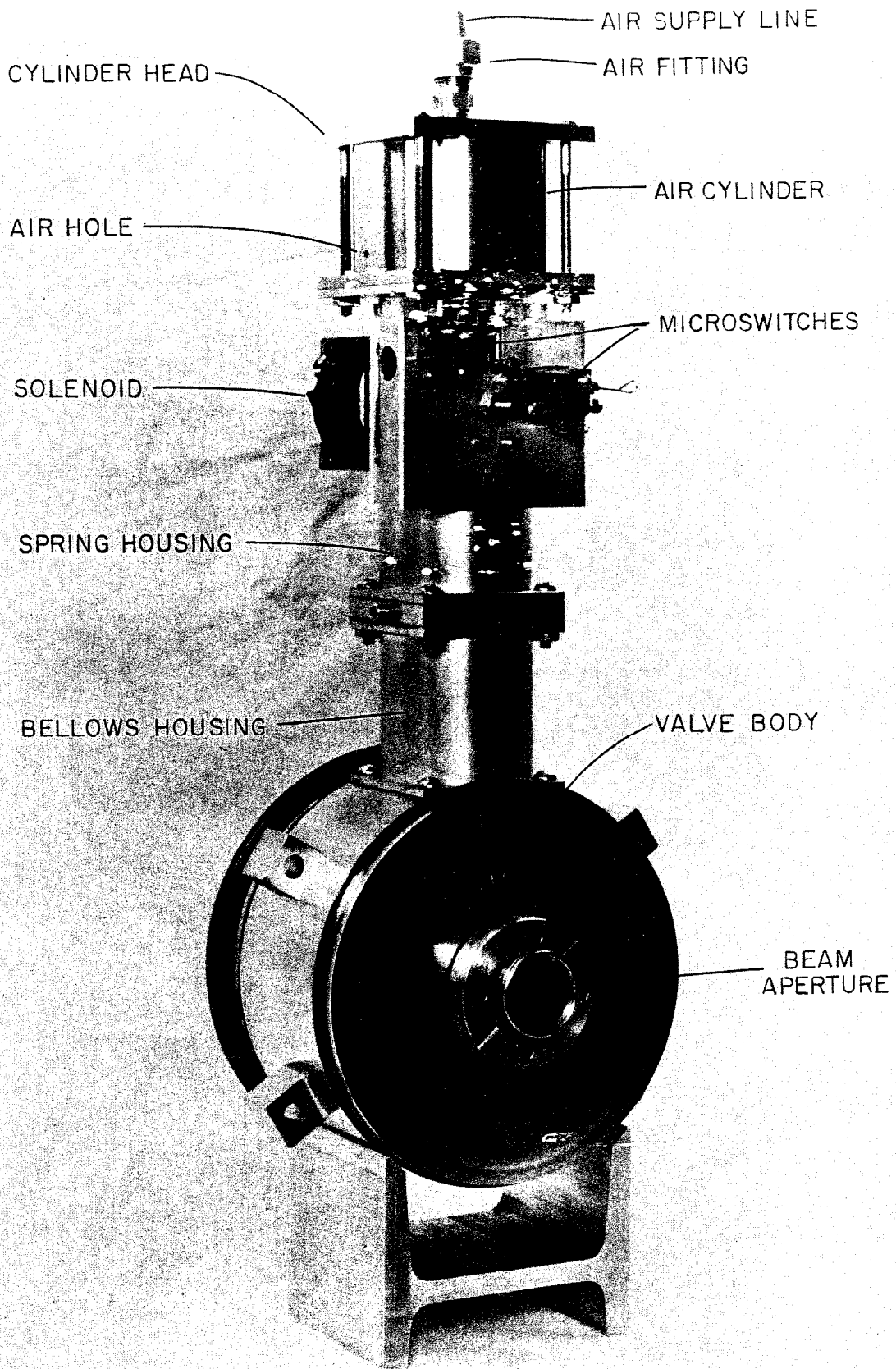

FIG. 2
 WAVEGUIDE VALVE ASSEMBLY
 CROSS-SECTIONAL VIEW

121-2-C



230-1-A

FIG. 3 - ASSEMBLED FAST CLOSING VACUUM VALVE

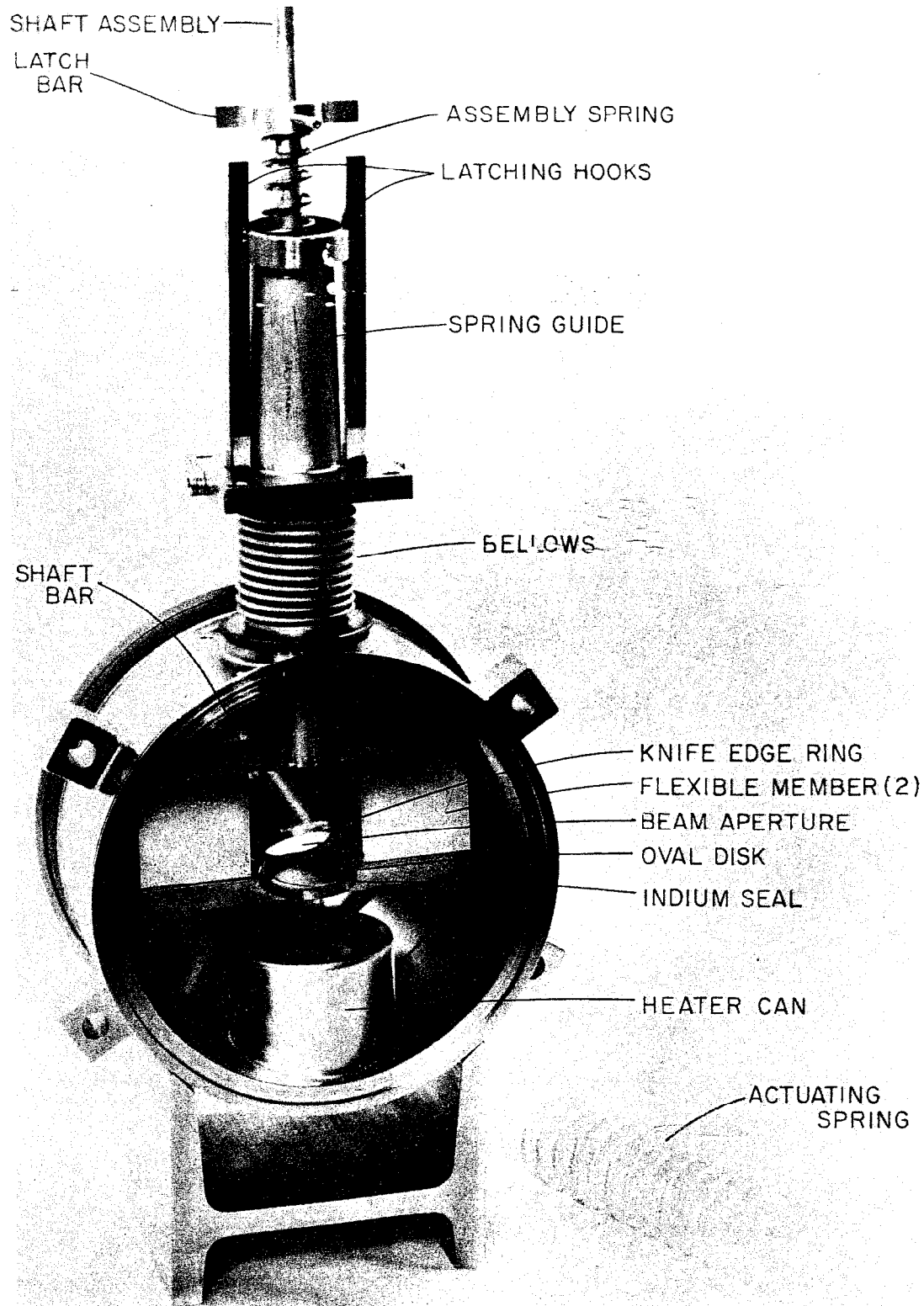

230-3-A

FIG. 4 - FAST CLOSING VALVE, PARTIALLY DISASSEMBLED

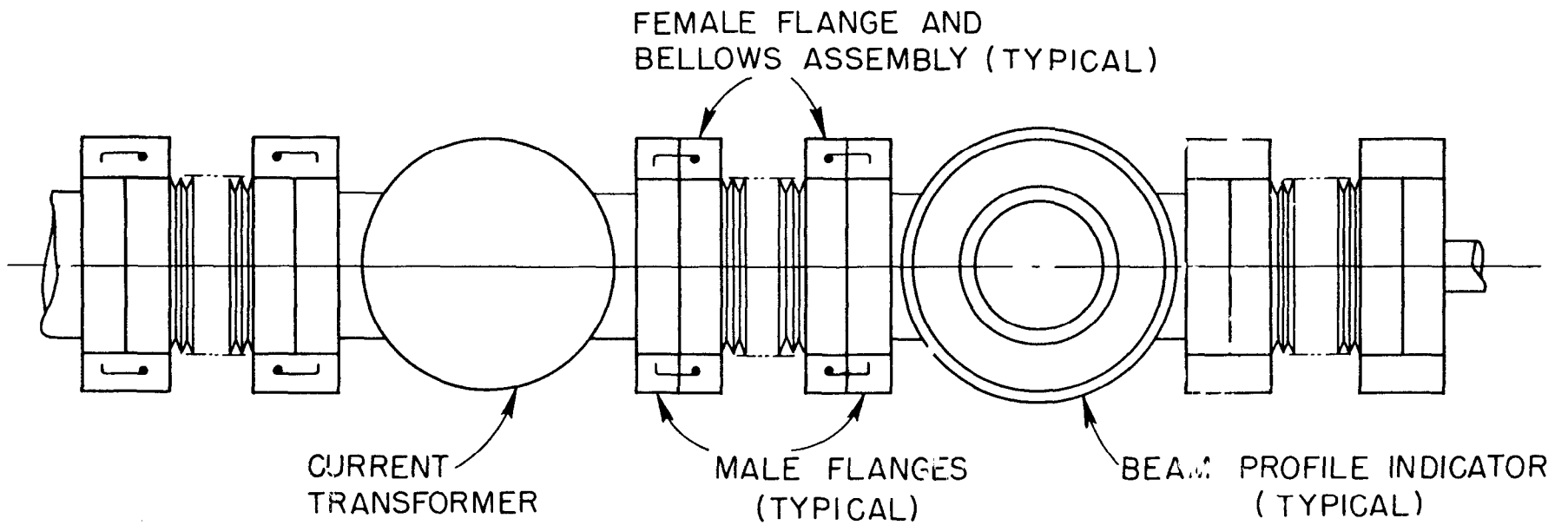
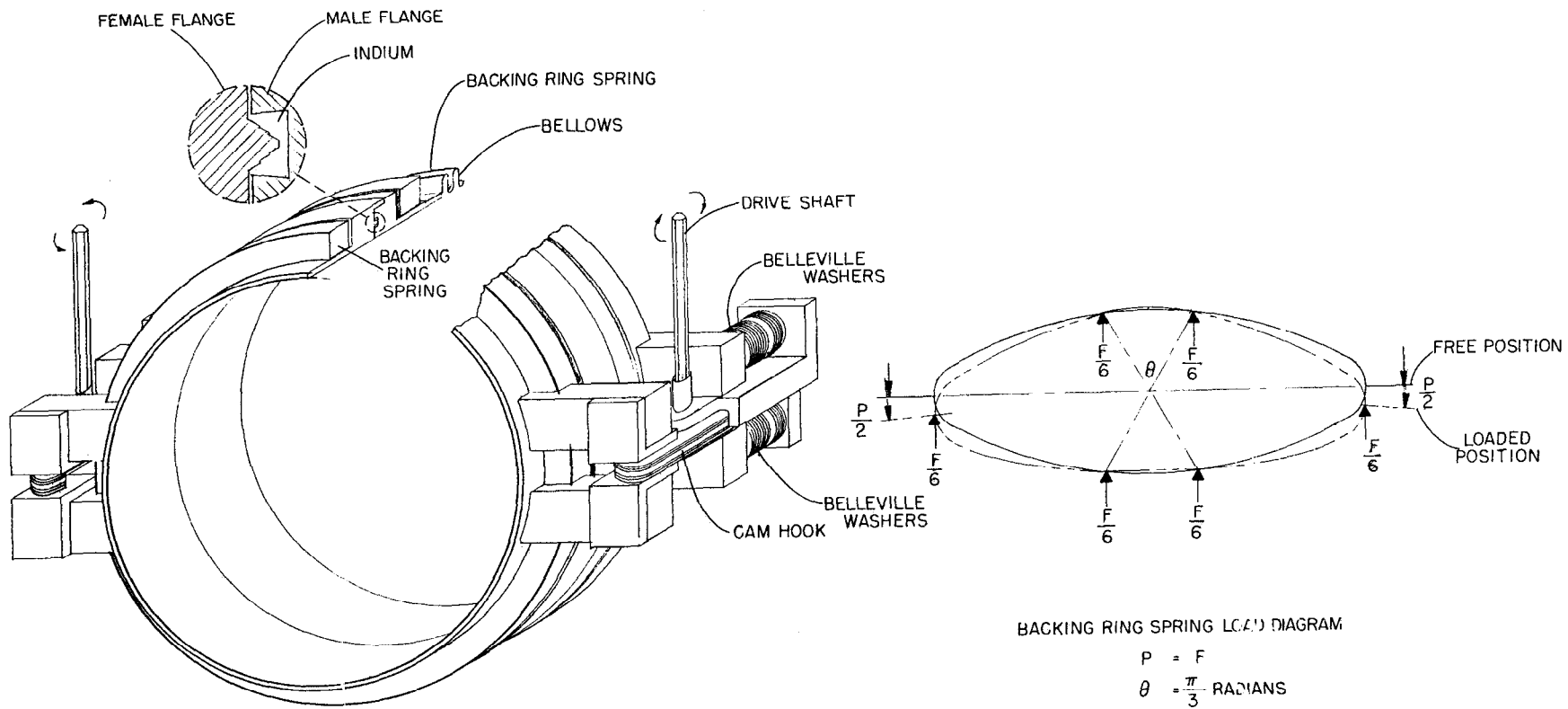

FIG. 5 TYPICAL ARRANGEMENT OF QUICK-DISCONNECT COUPLINGS
AND BSY COMPONENTS



QUICK DISCONNECT VACUUM COUPLING

230-6-C

FIG. 6 - CROSS-SECTION VIEW OF QUICK-DISCONNECT VACUUM COUPLING

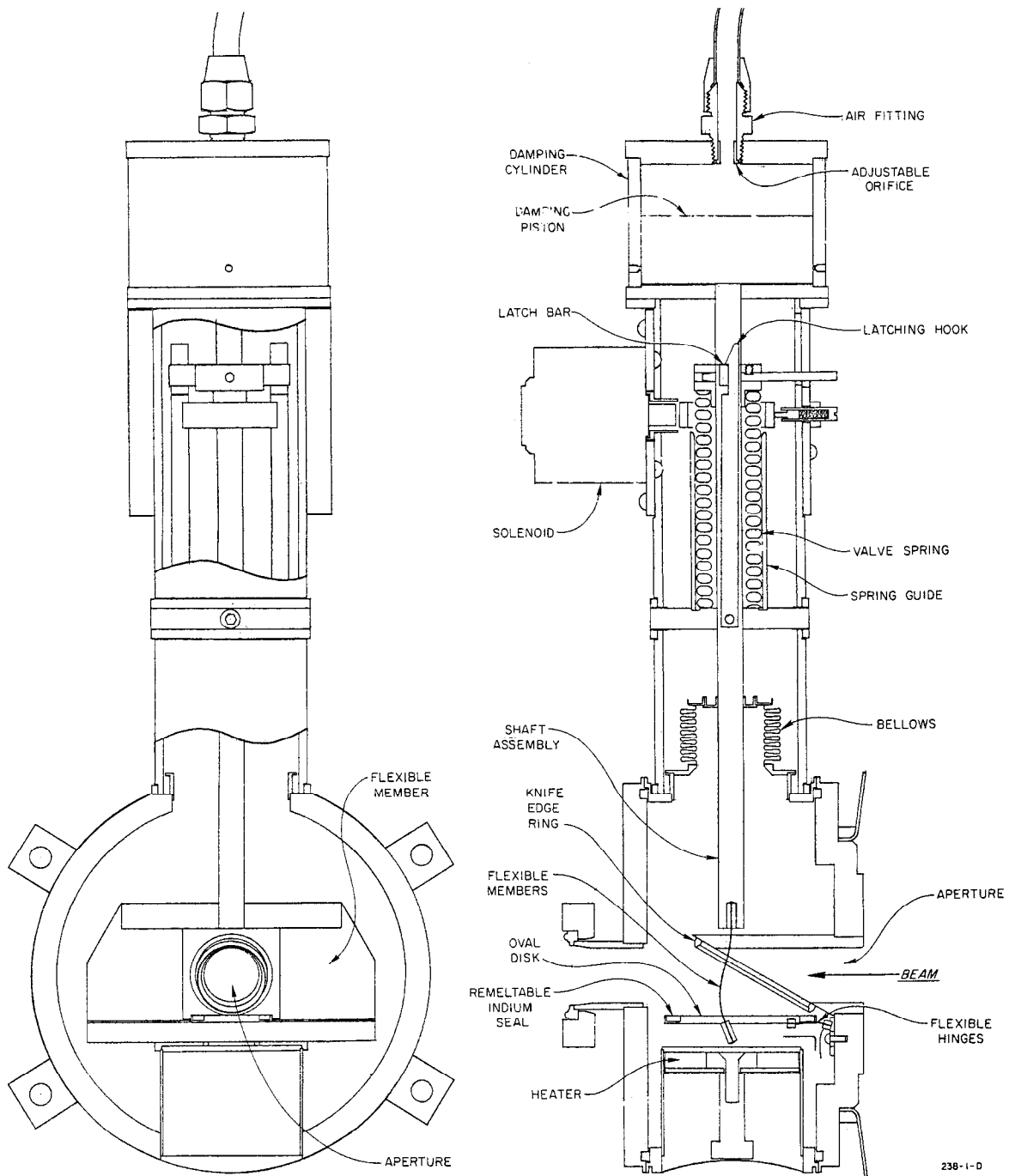

238-1-D

CROSS-SECTIONAL VIEW FAST-ACTING VALVE