

QCD Phenomenology and Nucleon Structure



Stan Brodsky, SLAC

Lecture V



National Nuclear Physics Summer School

QCD Lagrangian

The diagram shows the QCD Lagrangian L_{QCD} enclosed in a red box. Above the box, three labels with arrows point to parts of the equation: 'gluon dynamics' points to the first term, 'quark kinetic energy + quark-gluon dynamics' points to the second term, and 'mass term' points to the third term. Below the box, four labels with arrows point to specific parts: 'QCD color charge' points to $4g^2$, 'field strength tensor' points to $G_{\mu\nu}$, 'covariant derivative' points to D_μ , and 'quark field' points to ψ_f .

$$L_{\text{QCD}} = -\frac{1}{4g^2} \text{Tr}(G^{\mu\nu} G_{\mu\nu}) + \sum_{f=1}^{nf} i \bar{\psi}_f D_\mu \gamma^\mu \psi_f + \sum_{f=1}^{nf} m_f \bar{\psi}_f \psi_f$$

QCD: $N_C = 3$ Quarks: 3_C Gluons: 8_C .

$\alpha_s = \frac{g^2}{4\pi}$ is dimensionless

Classical Lagrangian is scale invariant for massless quarks

If $\beta = \frac{d\alpha_s(Q^2)}{d \log Q^2} = 0$ then QCD is invariant under conformal transformations:

Parisi

Conformal symmetry: Template for QCD

- Initial approximation to PQCD; then correct for non-zero beta function and quark masses
- Commensurate scale relations: relate observables at corresponding scales: Generalized Crewther Relation
- Arguments for Infrared fixed-point for α_s Alhofer, et al.
- Effective Charges: analytic at quark mass thresholds, finite at small momenta
- Eigensolutions of Evolution Equation of distribution amplitudes

The Renormalization Scale Problem

$$\rho = C_1 \alpha_s(\mu_R) + C_2 \alpha_s^2(\mu_R) + C_3 \alpha_s^3(\mu_R) + \dots$$

*How does one set the
renormalization scale μ_R ?*

Electron-Electron Scattering in QED

$$\mathcal{M}_{ee \rightarrow ee}(++; ++)=\frac{8\pi s}{t}\alpha(t)+\frac{8\pi s}{u}\alpha(u)$$

- No renormalization scale ambiguity!
- Two separate physical scales.
- Gauge Invariant. Dressed photon propagator
- Sums all vacuum polarization, non-zero beta terms into running coupling.
- If one chooses a different scale, one must sum an infinite number of graphs -- but then recover same result!
- Number of active leptons correctly set
- Analytic: reproduces correct behavior at lepton mass thresholds

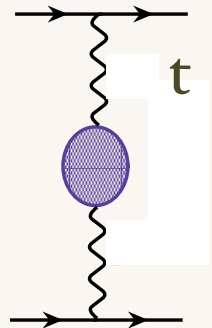

$$e^+ e^- \rightarrow \mu^+ \mu^-$$

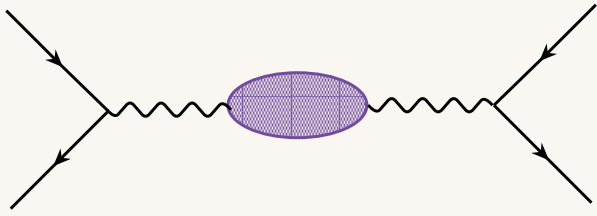

$$\mu_R^2 = s$$

Scale of $\alpha(\mu_r)$ unique !

$$M \propto \alpha(s)$$

The QED Effective Charge

- Complex
- Analytic through mass thresholds
- Distinguishes between timelike and spacelike momenta

Analyticity essential!

The Renormalization Scale Problem

M. Binger, sjb

- No renormalization scale ambiguity in QED
- Gell Mann-Low-Dyson QED Coupling defined from physical observable;
- Sums all Vacuum Polarization Contributions
- Recover conformal series
- Renormalization Scale in QED scheme: Identical to Photon Virtuality
- Analytic: Reproduces lepton-pair thresholds
- Examples: muonic atoms, $g-2$, Lamb Shift
- Time-like and Space-like QED Coupling related by analyticity
- Uses Dressed Skeleton Expansion

Lessons from QED : Summary

- Effective couplings are complex analytic functions with the correct threshold structure expected from unitarity
- Multiple “renormalization” scales appear
- The scales are unambiguous since they are physical kinematic invariants
- Optimal improvement of perturbation theory

BLM Scale Setting

$$\rho = C_0 \alpha_{\overline{\text{MS}}}(Q) \left[1 + \frac{\alpha_{\overline{\text{MS}}}(Q)}{\pi} \left(-\frac{3}{2} \beta_0 A_{\text{VP}} + \frac{33}{2} A_{\text{VP}} + B \right) + \dots \right]$$

Use n_f dependence at NLO to identify A_{VP}

by

$$\rho = C_0 \alpha_{\overline{\text{MS}}}(Q^*) \left[1 + \frac{\alpha_{\overline{\text{MS}}}(Q^*)}{\pi} C_1^* + \dots \right],$$

where

Conformal Coefficient

$$Q^* = Q \exp(3A_{\text{VP}}),$$

$$C_1^* = \frac{33}{2} A_{\text{VP}} + B.$$

The term $33A_{\text{VP}}/2$ in C_1^* serves to remove that part of the constant B which renormalizes the leading-order coupling. The ratio of these gluonic corrections to the light-quark corrections is fixed by $\beta_0 = 11 - \frac{2}{3}n_f$.

*Use skeleton expansion
Gardi, Rathsmann, sjb*

$$R_{e^+e^-}(Q^2) \equiv 3 \sum_{\text{flavors}} e_q^2 \left[1 + \frac{\alpha_R(Q)}{\pi} \right].$$

$$R_{e^+e^-}(Q^2) = 3 \sum_q e_q^2 \left[1 + \frac{\alpha_{\overline{\text{MS}}}(Q)}{\pi} + \frac{\alpha_{\overline{\text{MS}}}^2}{\pi^2} (1.98 - 0.115n_f) + \dots \right]$$

$$\rightarrow 3 \sum_q e_q^2 \left[1 + \frac{\alpha_{\overline{\text{MS}}}(Q^*)}{\pi} + \frac{\alpha_{\overline{\text{MS}}}^2(Q^*)}{\pi^2} 0.08 + \dots \right],$$

$Q^* = 0.710Q$. Notice that $\alpha_R(Q)$ differs from $\alpha_{\overline{\text{MS}}}(Q^*)$ by only $0.08\alpha_{\overline{\text{MS}}}/\pi$, so that $\alpha_R(Q)$ and $\alpha_{\overline{\text{MS}}}(0.71Q)$ are effectively interchangeable (for any value of n_f).

$$V(Q^2) = -\frac{C_F 4\pi\alpha_{\overline{\text{MS}}}(Q)}{Q^2} \left[1 + \frac{\alpha_{\overline{\text{MS}}}}{\pi} \left(\frac{5}{12}\beta_0 - 2 \right) + \dots \right] \quad (19a)$$

$$\rightarrow -\frac{C_F 4\pi\alpha_{\overline{\text{MS}}}(Q^*)}{Q^2} \left[1 - \frac{\alpha_{\overline{\text{MS}}}(Q^*)}{\pi} 2 + \dots \right], \quad (19b)$$

where $Q^* = e^{-5/6} Q$, $Q \cong 0.43Q$. This result shows that the effective scale of the $\overline{\text{MS}}$ scheme should generally be about half of the true momentum transfer occurring in the interaction. In parallel to QED, the effective potential $V(Q^2)$ gives a particularly intuitive scheme for defining the QCD coupling constant

$$V(Q^2) \equiv -\frac{4\pi C_F \alpha_v(Q)}{Q^2} \quad (20)$$

Features of BLM Scale Setting

On The Elimination Of Scale Ambiguities In Perturbative Quantum Chromodynamics.

Lepage, Mackenzie, sjb

Phys.Rev.D28:228,1983

- All terms associated with nonzero beta function summed into running coupling
- BLM Scale Q^* sets the number of active flavors
- Only n_f dependence required to determine renormalization scale at NLO
- Result is scheme independent: Q^* has exactly the correct dependence to compensate for change of scheme
- Correct Abelian limit
- **Resulting series identical to conformal series!**
- Renormalon $n!$ growth of PQCD coefficients from beta function eliminated!
- In general, BLM scale depends on all invariants

Deep-inelastic scattering. The moments of the nonsinglet structure function $F_2(x, Q^2)$ obey the evolution equation

$$\begin{aligned}
 Q^2 \frac{d}{dQ^2} \ln M_n(Q^2) &= -\frac{\gamma_n^{(0)}}{8\pi} \alpha_{\overline{\text{MS}}}(Q) \left[1 + \frac{\alpha_{\overline{\text{MS}}}}{4\pi} \frac{2\beta_0\beta_n + \gamma_n^{(1)}}{\gamma_n^{(0)}} + \dots \right] \\
 &\rightarrow -\frac{\gamma_n^{(0)}}{8\pi} \alpha_{\overline{\text{MS}}}(Q_n^*) \left[1 - \frac{\alpha_{\overline{\text{MS}}}(Q_n^*)}{\pi} C_n + \dots \right],
 \end{aligned}$$

where, for example,

$$Q_2^* = 0.48Q, \quad C_2 = 0.27,$$

$$Q_{10}^* = 0.21Q, \quad C_{10} = 1.1.$$

For n very large, the effective scale here becomes $Q_n^* \sim Q/\sqrt{n}$.

BLM scales for DIS moments

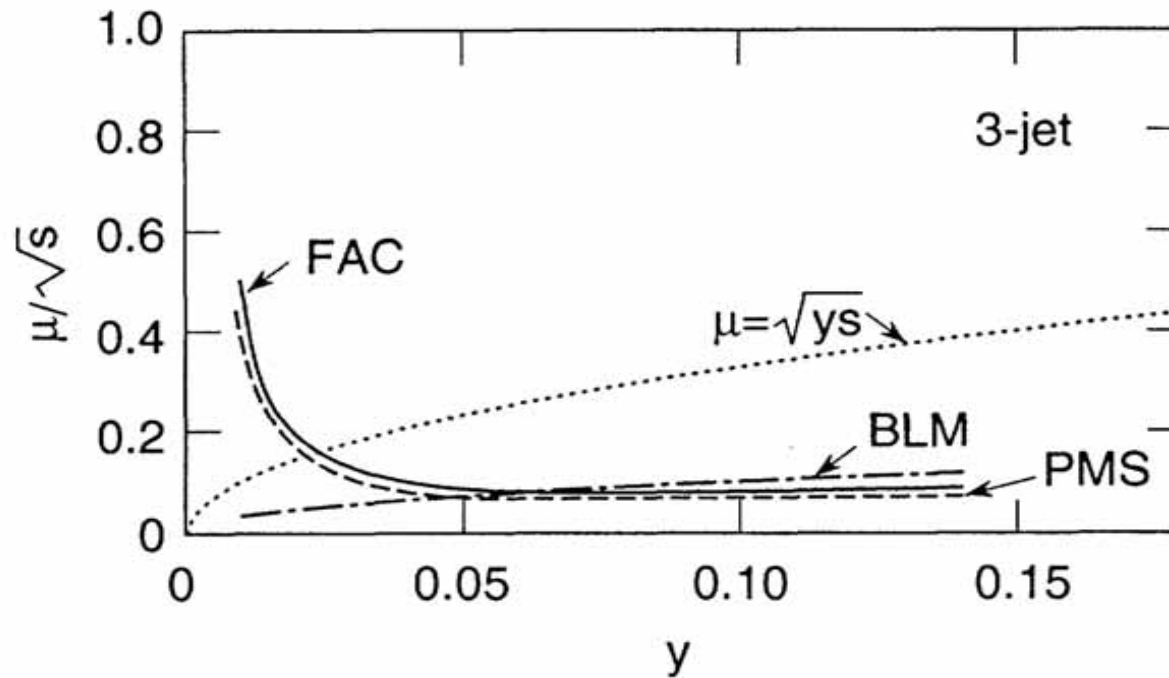

Kramer & Lampe

Three-Jet Rate

The scale μ/\sqrt{s} according to the BLM (dashed-dotted), PMS (dashed), FAC (full), and \sqrt{y} (dotted) procedures for the three-jet rate in e^+e^- annihilation, as computed by Kramer and Lampe [10]. Notice the strikingly different behavior of the BLM scale from the PMS and FAC scales at low y . In particular, the latter two methods predict increasing values of μ as the jet invariant mass $\mathcal{M} < \sqrt{(ys)}$ decreases.

Rathsman

Other Jet Observables:

$$V(Q^2) = -\frac{C_F 4\pi\alpha_{\overline{\text{MS}}}(Q)}{Q^2} \left[1 + \frac{\alpha_{\overline{\text{MS}}}}{\pi} \left(\frac{5}{12}\beta_0 - 2 \right) + \dots \right]$$

$$\rightarrow -\frac{C_F 4\pi\alpha_{\overline{\text{MS}}}(Q^*)}{Q^2} \left[1 - \frac{\alpha_{\overline{\text{MS}}}(Q^*)}{\pi} 2 + \dots \right],$$

where $Q^* = e^{-5/6} Q \cong 0.43Q$. This result shows that the effective scale of the $\overline{\text{MS}}$ scheme should generally be about half of the true momentum transfer occurring in the interaction. In parallel to QED, the effective potential $V(Q^2)$ gives a particularly intuitive scheme for defining the QCD coupling constant

$$V(Q^2) \equiv -\frac{4\pi C_F \alpha_v(Q)}{Q^2}$$

*Application of BLM
to Multi-Scale Threshold Production*

Hoang, Kuhn, Tuebner, SJB
Phys.Lett.B359:355-361,1995

Perturbative Qcd Effects In Heavy Meson Decays.

Adam Szczepaniak, Ernest M. Henley (Washington U., Seattle),
 Stanley J. Brodsky (SLAC). SLAC-PUB-5228, Mar 1990. 14pp.
 Published in Phys.Lett.B243:287-292,1990

$$B \rightarrow \pi \ell \bar{\nu}$$

$$B \rightarrow \pi \pi$$

$$\langle L_i | V^\mu | H \rangle =$$

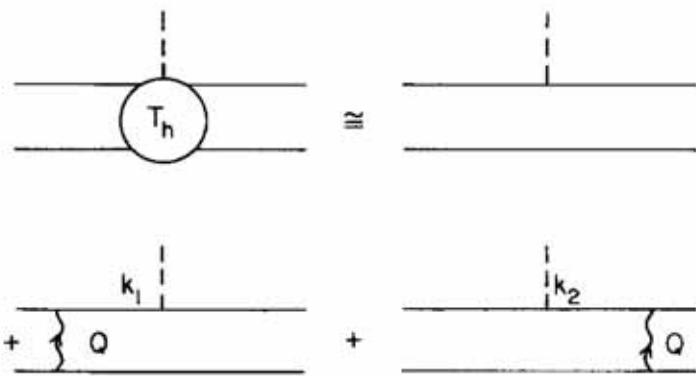
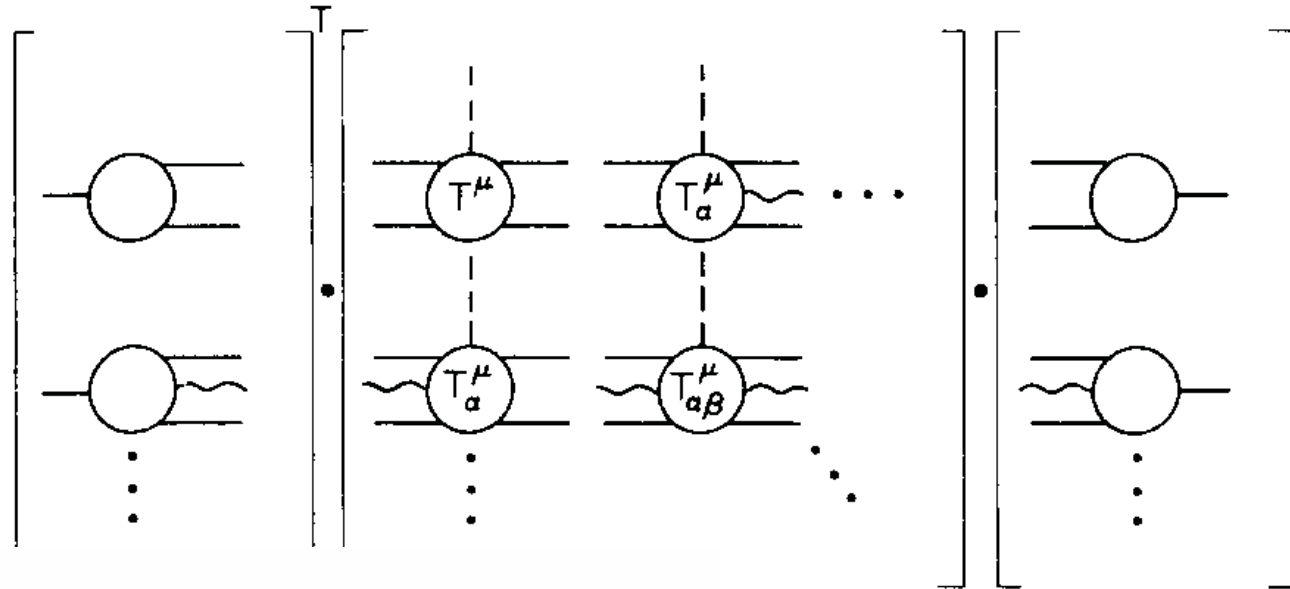

Multiple BLM scales

$$\alpha_{\overline{MS}}(e^{-5/3} Q^2)$$

Features of BLM Scale Setting

- All terms associated with nonzero beta function summed into running coupling
- Conformal series preserved
- BLM Scale Q^* sets the number of active flavors
- Correct analytic dependence in the quark mass
- Only n_f dependence required to determine renormalization scale at NLO
- Result is scheme independent: Q^* has exactly the correct dependence to compensate for change of scheme
- Correct Abelian limit!

$\lim N_C \rightarrow 0$ at fixed $\alpha = C_F \alpha_s, n_\ell = n_F / C_F$

QCD \rightarrow Abelian Gauge Theory

*Analytic Feature of
SU(Nc) Gauge
Theory*

Huet, sjb

Relate Observables to Each Other

- Eliminate intermediate scheme
- No scale ambiguity
- Transitive!
- Commensurate Scale Relations
- Example: Generalized Crewther Relation

$$\begin{aligned}
\frac{\alpha_R(Q)}{\pi} = & \frac{\alpha_{\overline{\text{MS}}}(Q)}{\pi} + \left(\frac{\alpha_{\overline{\text{MS}}}(Q)}{\pi} \right)^2 \left[\left(\frac{41}{8} - \frac{11}{3} \zeta_3 \right) C_A - \frac{1}{8} C_F + \left(-\frac{11}{12} + \frac{2}{3} \zeta_3 \right) f \right] \\
& + \left(\frac{\alpha_{\overline{\text{MS}}}(Q)}{\pi} \right)^3 \left\{ \left(\frac{90445}{2592} - \frac{2737}{108} \zeta_3 - \frac{55}{18} \zeta_5 - \frac{121}{432} \pi^2 \right) C_A^2 + \left(-\frac{127}{48} - \frac{143}{12} \zeta_3 + \frac{55}{3} \zeta_5 \right) C_A C_F - \frac{23}{32} C_F^2 \right. \\
& + \left[\left(-\frac{970}{81} + \frac{224}{27} \zeta_3 + \frac{5}{9} \zeta_5 + \frac{11}{108} \pi^2 \right) C_A + \left(-\frac{29}{96} + \frac{19}{6} \zeta_3 - \frac{10}{3} \zeta_5 \right) C_F \right] f \\
& \left. + \left(\frac{151}{162} - \frac{19}{27} \zeta_3 - \frac{1}{108} \pi^2 \right) f^2 + \left(\frac{11}{144} - \frac{1}{6} \zeta_3 \right) \frac{d^{abc} d^{abc}}{C_F d(R)} \frac{\left(\sum_f Q_f \right)^2}{\sum_f Q_f^2} \right\}.
\end{aligned}$$

$$\begin{aligned}
\frac{\alpha_{g_1}(Q)}{\pi} = & \frac{\alpha_{\overline{\text{MS}}}(Q)}{\pi} + \left(\frac{\alpha_{\overline{\text{MS}}}(Q)}{\pi} \right)^2 \left[\frac{23}{12} C_A - \frac{7}{8} C_F - \frac{1}{3} f \right] \\
& + \left(\frac{\alpha_{\overline{\text{MS}}}(Q)}{\pi} \right)^3 \left\{ \left(\frac{5437}{648} - \frac{55}{18} \zeta_5 \right) C_A^2 + \left(-\frac{1241}{432} + \frac{11}{9} \zeta_3 \right) C_A C_F + \frac{1}{32} C_F^2 \right. \\
& \left. + \left[\left(-\frac{3535}{1296} - \frac{1}{2} \zeta_3 + \frac{5}{9} \zeta_5 \right) C_A + \left(\frac{133}{864} + \frac{5}{18} \zeta_3 \right) C_F \right] f + \frac{115}{648} f^2 \right\}.
\end{aligned}$$

**Apply BLM, Eliminate MSbar,
Find Amazing Simplification**

$$\int_0^1 dx \left[g_1^{ep}(x, Q^2) - g_1^{en}(x, Q^2) \right] \equiv \frac{1}{3} \left| \frac{g_A}{g_V} \right| \left[1 - \frac{\alpha_{g_1}(Q)}{\pi} \right]$$

$$\frac{\alpha_{g_1}(Q)}{\pi} = \frac{\alpha_R(Q^*)}{\pi} - \left(\frac{\alpha_R(Q^{**})}{\pi} \right)^2 + \left(\frac{\alpha_R(Q^{***})}{\pi} \right)^3$$

Geometric Series in Conformal QCD

Generalized Crewther Relation

add Light-by-Light

Lu, Kataev, Gabadadze, Sjb

Generalized Crewther Relation

$$\left[1 + \frac{\alpha_R(s^*)}{\pi}\right] \left[1 - \frac{\alpha_{g_1}(q^2)}{\pi}\right] = 1$$

$$\sqrt{s^*} \simeq 0.52Q$$

*Conformal relation true to all orders in
perturbation theory*

Transitivity property - Renormalization Group

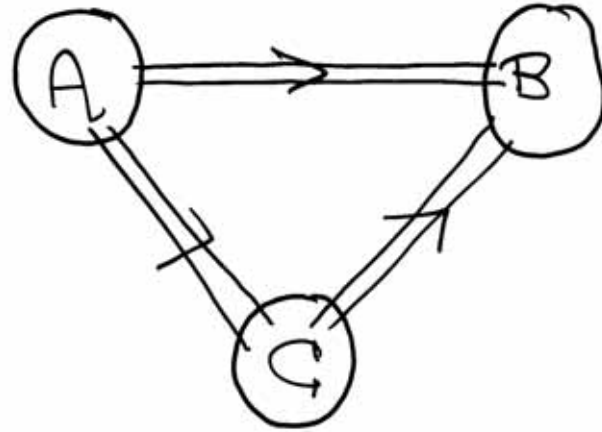

$$\boxed{A \Rightarrow C \Rightarrow B}$$

same as $\boxed{A \Rightarrow B}$

indep of \boxed{C}

Relation between observable $A \Leftrightarrow B$
independent of choice of G
independent of scheme or
theoretical convention!

PMS violates
transitivity

Commensurate Scale Relation:

$$* \alpha_B(Q_B) = \alpha_A(Q_A) \left[1 + C_{A/B}^{(1)} \frac{\alpha_A}{\pi} + \dots \right]$$

↑
conformal coeff.

$$Q_B/Q_A = \lambda_{B/A}$$

Peterman	}	$\lambda_{B/A} = \lambda_{B/C} / \lambda_{A/C}$	transitive
Stüchelberg		$\lambda_{B/A} = \lambda_{A/B}^{-1}$	symmetry
Renormalization "Group"		$\lambda_{A/A} = I$	identity

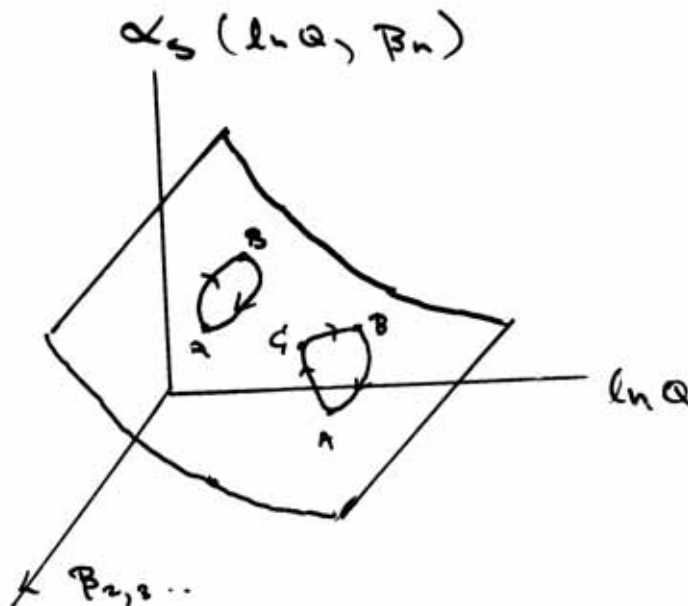

Leading Order Commensurate Scales

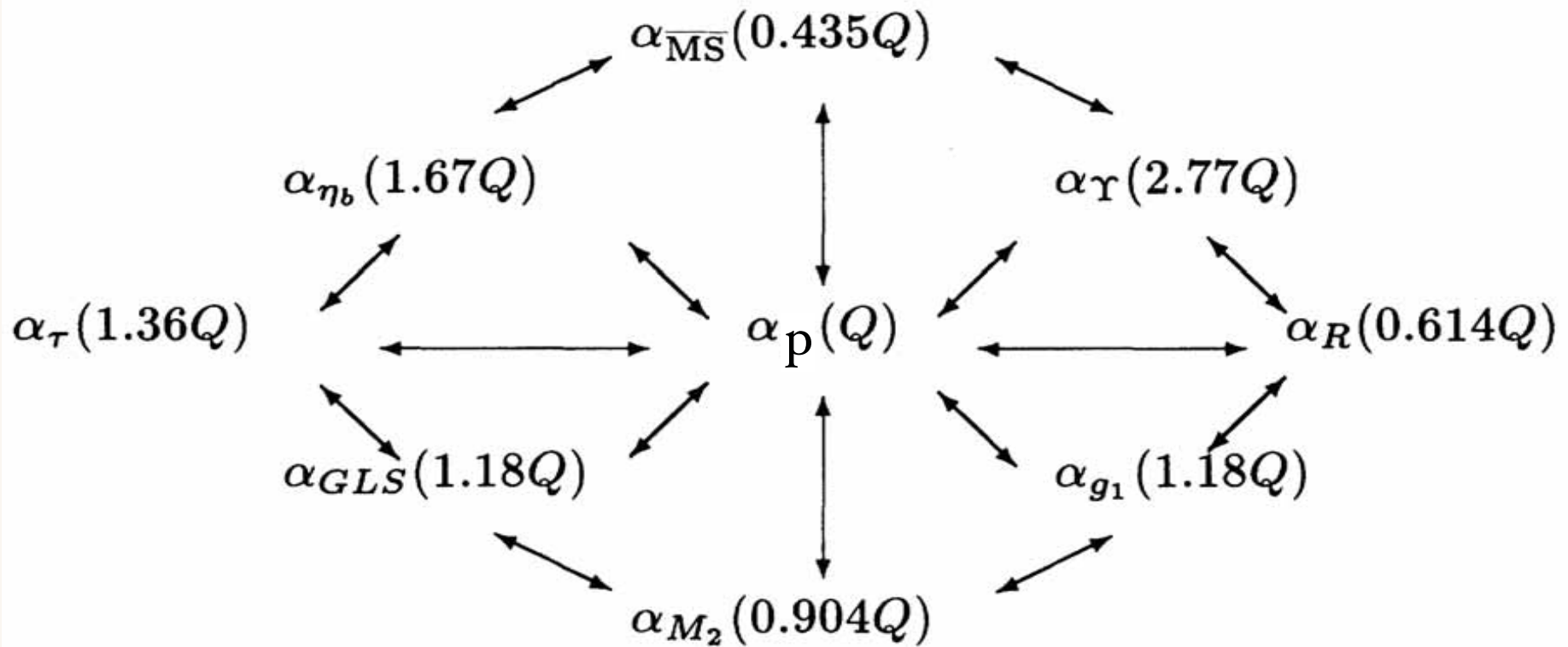

Translate between schemes at LO

Production of four heavy-quark jets

M. Binger, sjb

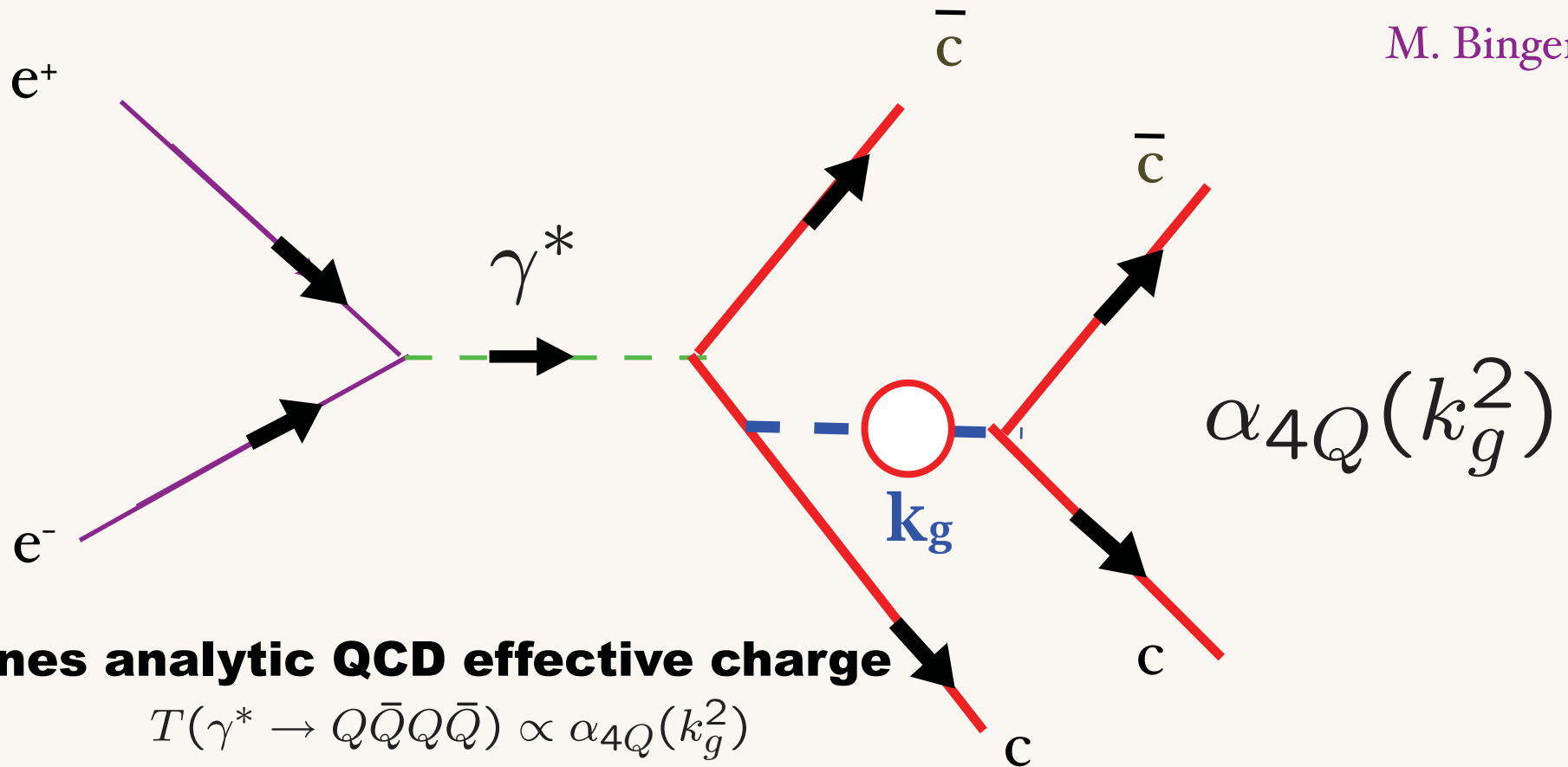

Defines analytic QCD effective charge

$$T(\gamma^* \rightarrow Q\bar{Q}Q\bar{Q}) \propto \alpha_{4Q}(k_g^2)$$

time-like values not same as space-like

coupling similar to “pinch” scheme

complex for time-like argument

Conventional renormalization scale-setting method:

- Guess arbitrary renormalization scale and take arbitrary range. Wrong for QED and Precision Electroweak.
- Prediction depends on choice of renormalization scheme
- Variation of result with respect to renormalization scale only sensitive to nonconformal terms; no information on genuine (conformal) higher order terms
- Conventional procedure has no scientific basis.
- FAC and PMS give unphysical results; have no validity.
- Renormalization scale not arbitrary! Sets # active flavors

The Pinch Technique

(Cornwall, Papavassiliou)

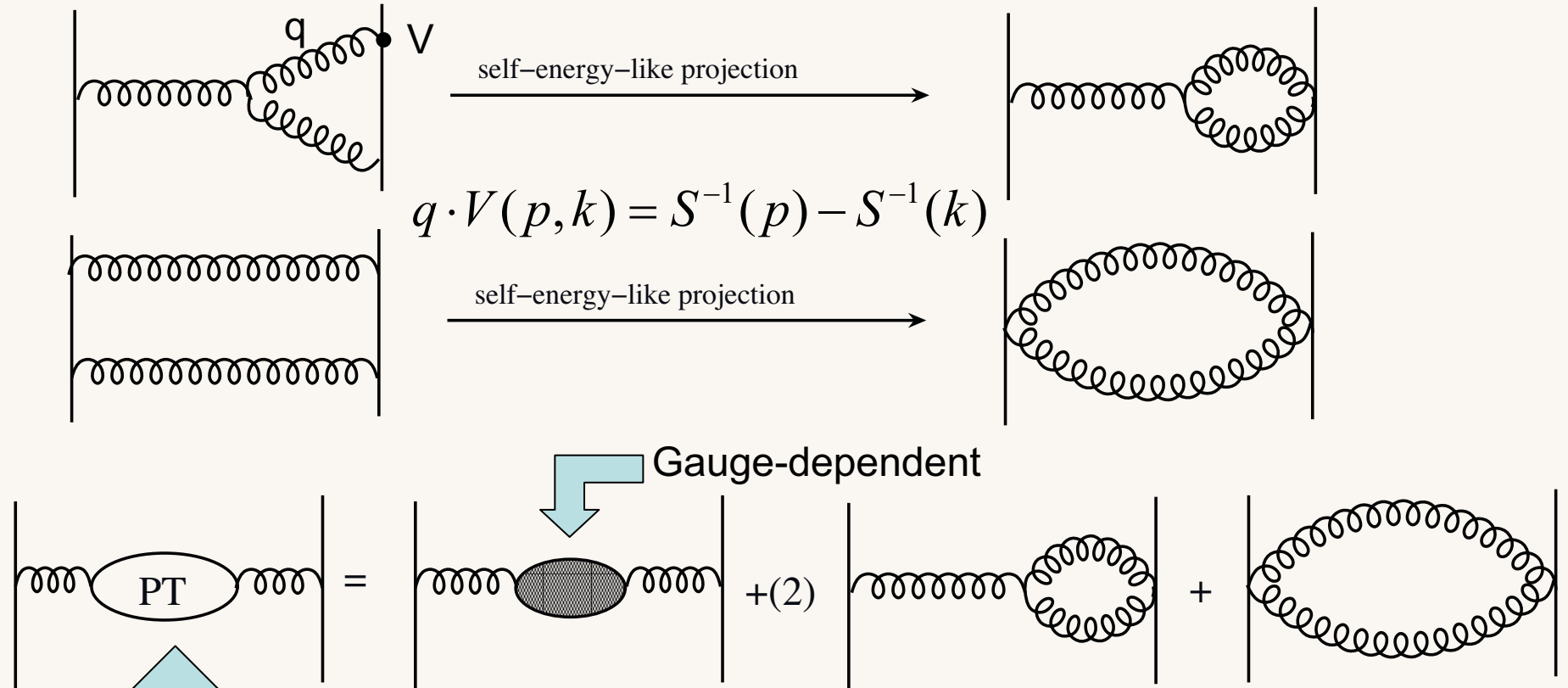

Gauge-invariant gluon self-energy!

natural generalization of QED charge

13

Use Physical Scheme to Characterize QCD Coupling

- Use Observable to define QCD coupling or Pinch Scheme
- Analytic: Smooth behavior as one crosses new quark threshold
- New perspective on grand unification

Asymptotic Unification

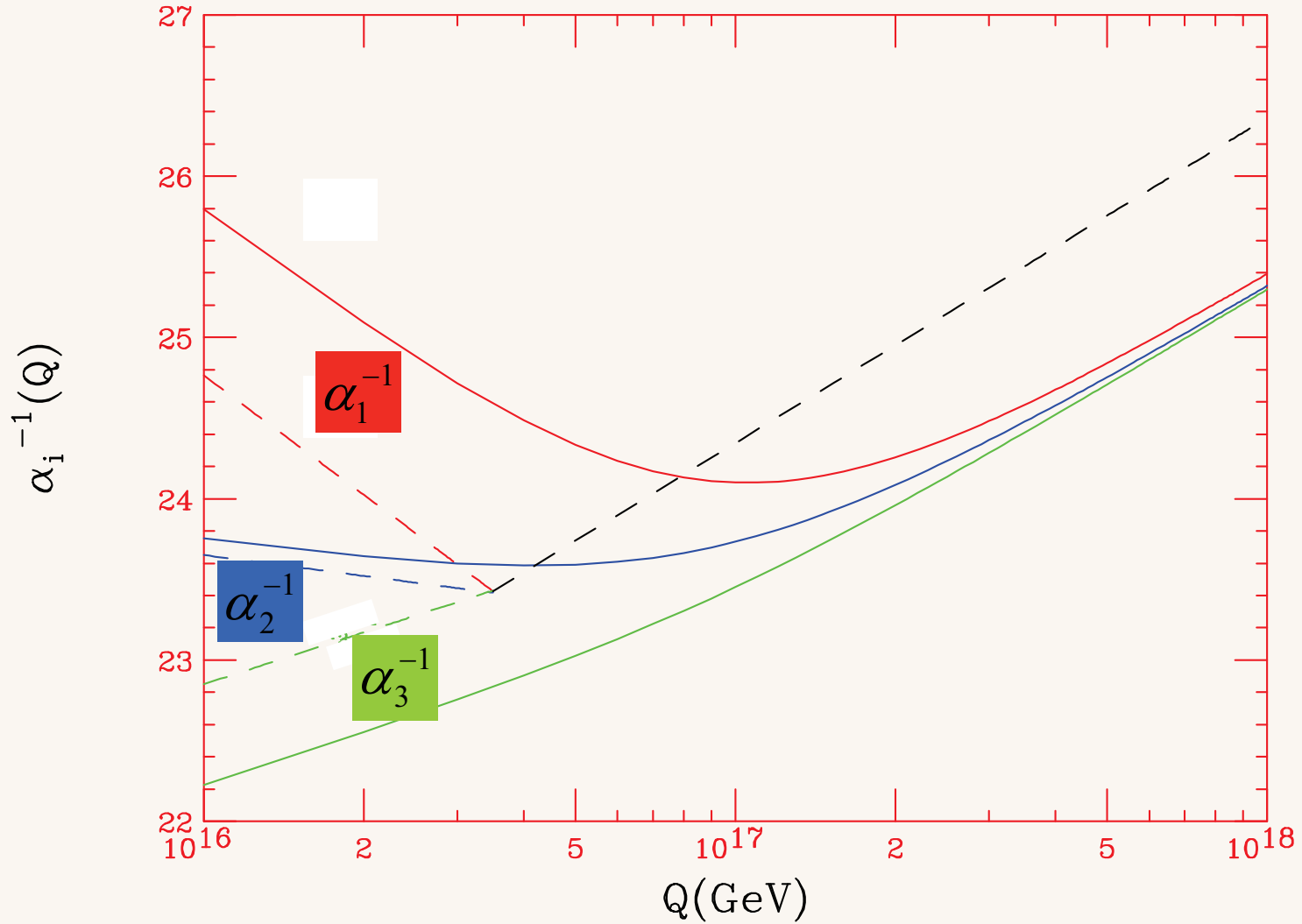

Binger, sjb

QCD Phenomenology

Stan Brodsky, SLAC

NNPSS
July 2006

Analyticity and Mass Thresholds

\overline{MS} does not have automatic decoupling of heavy particles



Must define a set of schemes in each desert region and match

$$\alpha_s^{(f)}(M_Q) = \alpha_s^{(f+1)}(M_Q)$$

- The coupling has **discontinuous derivative** at the matching point
- At higher orders the coupling itself becomes **discontinuous!**
- Does not distinguish between spacelike and timelike momenta

“AN ANALYTIC EXTENSION OF THE \overline{MS} -BAR RENORMALIZATION SCHEME”

S. Brodsky, M. Gill, M. Melles, J. Rathsman. **Phys.Rev.D58:116006,1998**

Unification in Physical Schemes

- Smooth analytic threshold behavior with automatic decoupling
- More directly reflects the unification of the forces
- Higher “unification” scale than usual

General Structure of the Three-Gluon Vertex

"THE FORM-FACTORS OF THE GAUGE-INVARIANT THREE-GLUON VERTEX"

Binger, sjb

hep-ph/0602199.

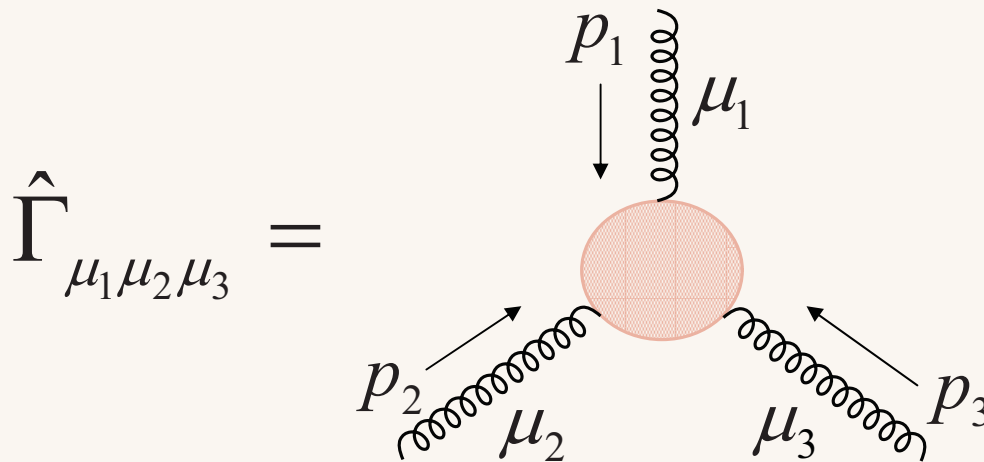

*Full calculation,
general masses, spin*

3 index tensor $\hat{\Gamma}_{\mu_1\mu_2\mu_3}$ built out of $g_{\mu\nu}$ and p_1, p_2, p_3
with $p_1 + p_2 + p_3 = 0$

➔ 14 basis tensors and form factors

The Gauge Invariant Three Gluon Vertex

Cornwall and Papavassiliou performed the PT construction :

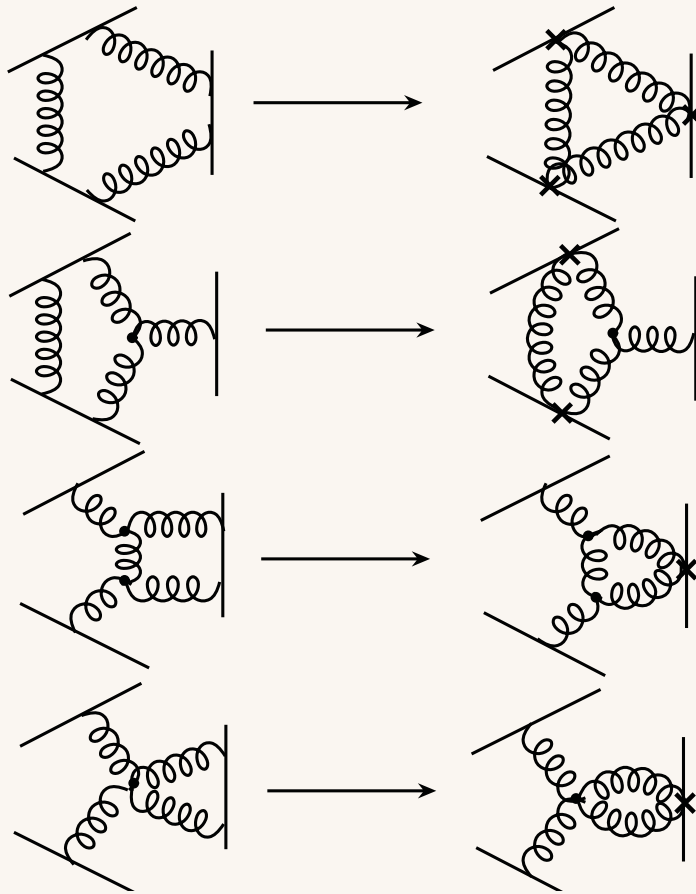

The “pinched” parts are added to the “regular” 3 gluon vertex

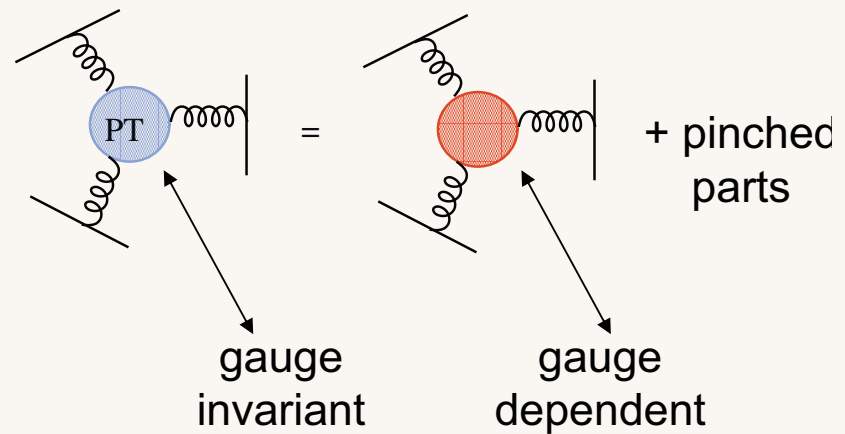

Summary of Supersymmetric Relations

Massless

$$F_G + 4F_Q + (10 - d)F_S = 0$$

$$\Sigma_{QG}(F) \equiv \frac{d-2}{2} F_Q + F_G$$

= simple

Massive

$$F_{MG} + 4F_{MQ} + (9 - d)F_{MS} = 0$$

$$\Sigma_{MQG}(F) \equiv \frac{d-1}{2} F_{MQ} + F_{MG}$$

= simple

Multi-scale Renormalization of the Three-Gluon Vertex

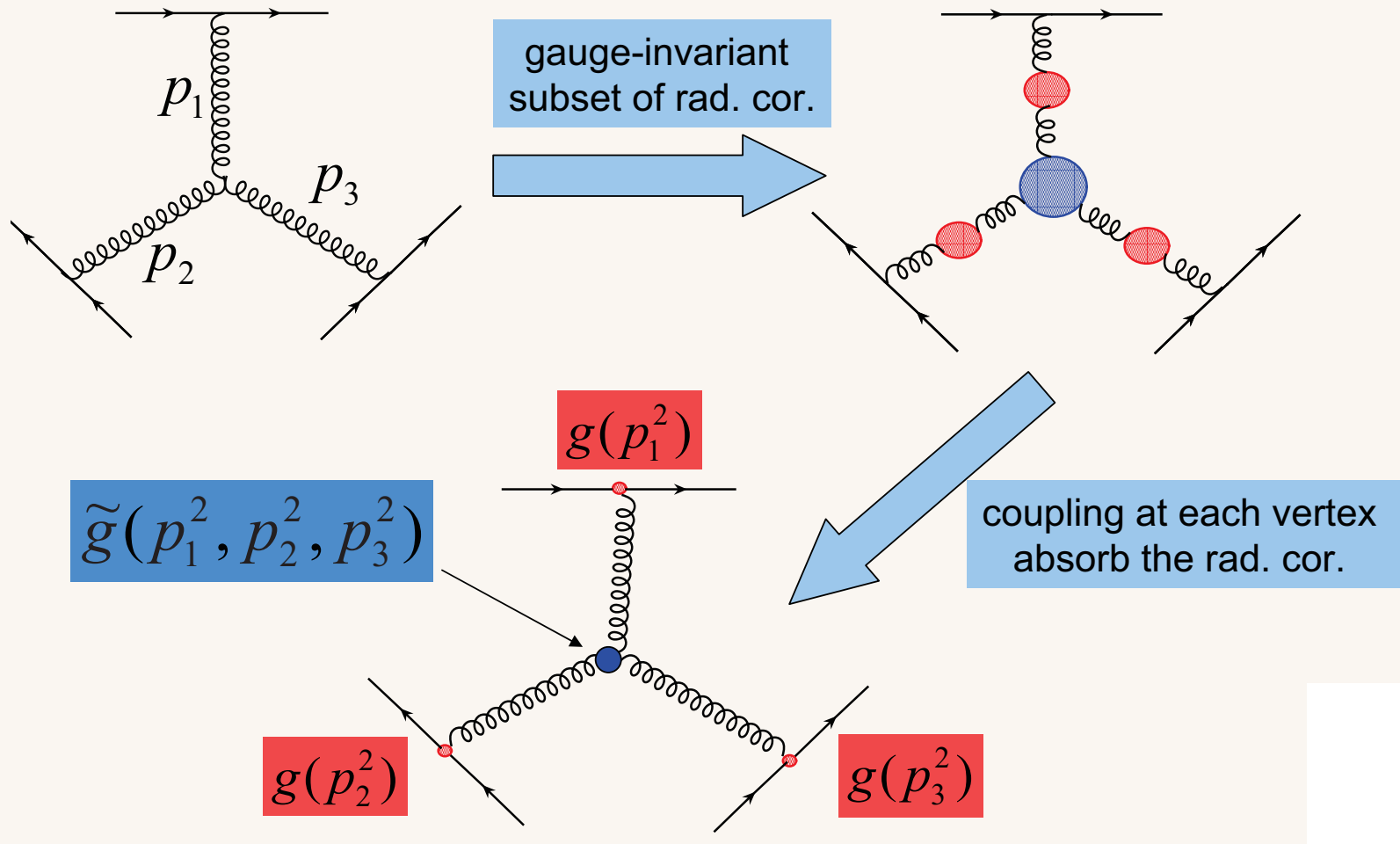

3 Scale Effective Charge

$$\tilde{\alpha}(a,b,c) \equiv \frac{\tilde{g}^2(a,b,c)}{4\pi} \quad (\text{First suggested by H.J. Lu})$$

$$\frac{1}{\tilde{\alpha}(a,b,c)} = \frac{1}{\alpha_{bare}} + \frac{1}{4\pi} \beta_0 \left(L(a,b,c) - \frac{1}{\varepsilon} + \dots \right)$$

$$\frac{1}{\tilde{\alpha}(a,b,c)} = \frac{1}{\tilde{\alpha}(a_0,b_0,c_0)} + \frac{1}{4\pi} \beta_0 [L(a,b,c) - L(a_0,b_0,c_0)]$$

$L(a,b,c)$ = 3-scale “log-like” function

$L(a,a,a) = \log(a)$

3 Scale Effective Scale

$$L(a, b, c) \equiv \log(Q_{eff}^2(a, b, c)) + i \text{Im} L(a, b, c)$$

Governs strength of the three-gluon vertex

$$\frac{1}{\tilde{\alpha}(a, b, c)} = \frac{1}{\tilde{\alpha}(a_0, b_0, c_0)} + \frac{1}{4\pi} \beta_0 [L(a, b, c) - L(a_0, b_0, c_0)]$$

$$\hat{\Gamma}_{\mu_1 \mu_2 \mu_3} \propto \sqrt{\tilde{\alpha}(a, b, c)}$$

Generalization of BLM Scale to 3-Gluon Vertex

Properties of the *Effective Scale*

$$Q_{\text{eff}}^2(a, b, c) = Q_{\text{eff}}^2(-a, -b, -c)$$

$$Q_{\text{eff}}^2(\lambda a, \lambda b, \lambda c) = |\lambda| Q_{\text{eff}}^2(a, b, c)$$

$$Q_{\text{eff}}^2(a, a, a) = |a|$$

$$Q_{\text{eff}}^2(a, -a, -a) \approx 5.54 |a|$$

$$Q_{\text{eff}}^2(a, a, c) \approx 3.08 |c| \quad \text{for } |a| \gg |c|$$

$$Q_{\text{eff}}^2(a, -a, c) \approx 22.8 |c| \quad \text{for } |a| \gg |c|$$

$$Q_{\text{eff}}^2(a, b, c) \approx 22.8 \frac{|bc|}{|a|} \quad \text{for } |a| \gg |b|, |c|$$

Surprising dependence on Invariants

The Effective Scale

$$Q_{eff}^2(10 \text{ GeV}^2, 10 \text{ GeV}^2, p^2)$$

$$Q_{eff}^2(-10 \text{ GeV}^2, -10 \text{ GeV}^2, p^2)$$

$$Q_{eff}^2(10 \text{ GeV}^2, p^2, p^2)$$

$$Q_{eff}^2(-10 \text{ GeV}^2, p^2, p^2)$$

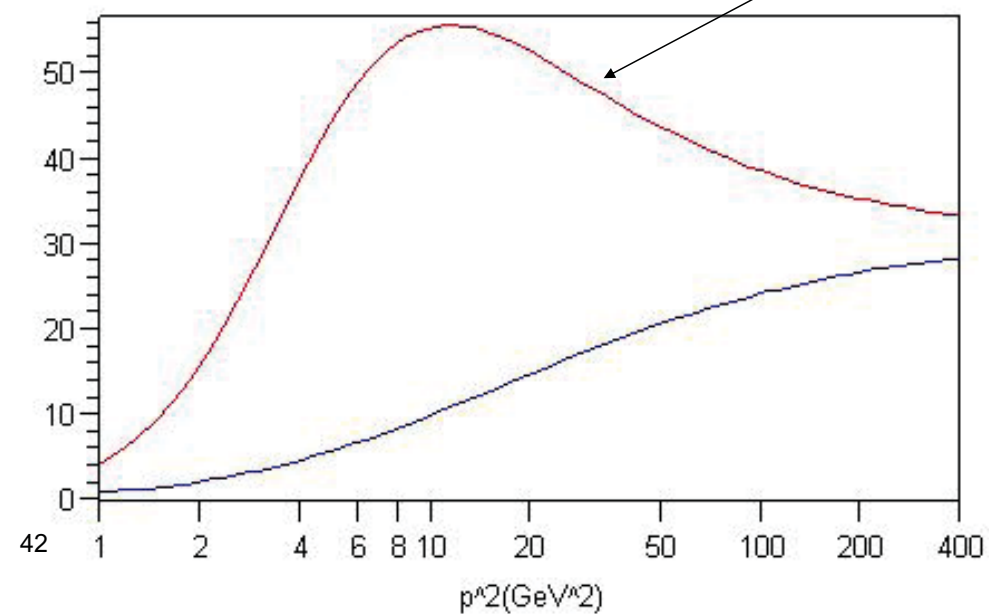
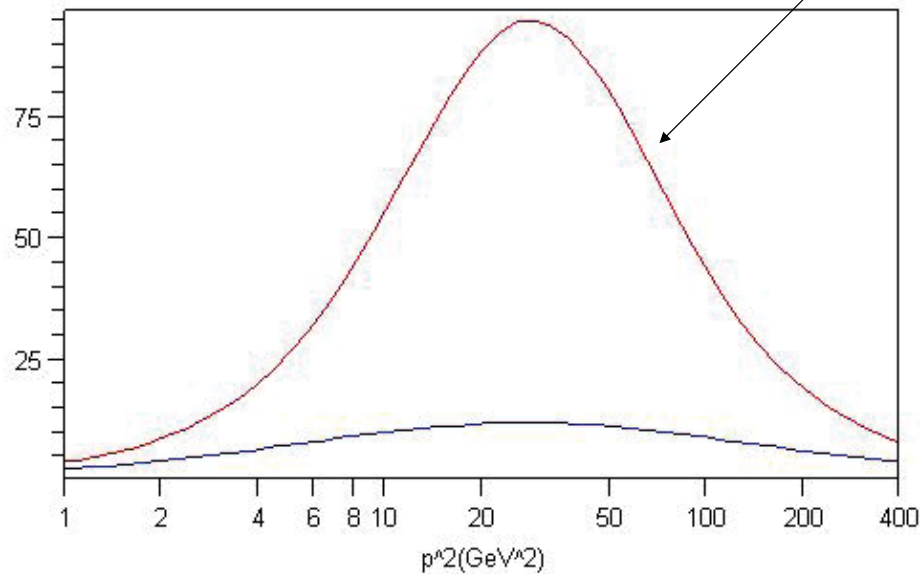

Heavy Quark Hadro-production

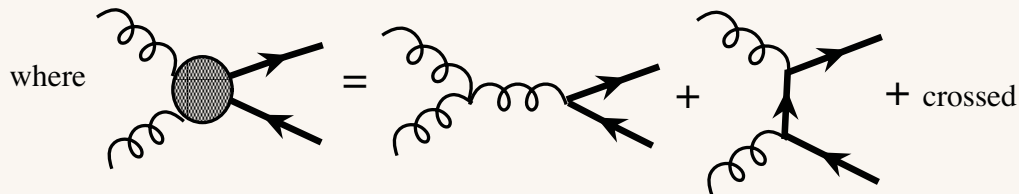
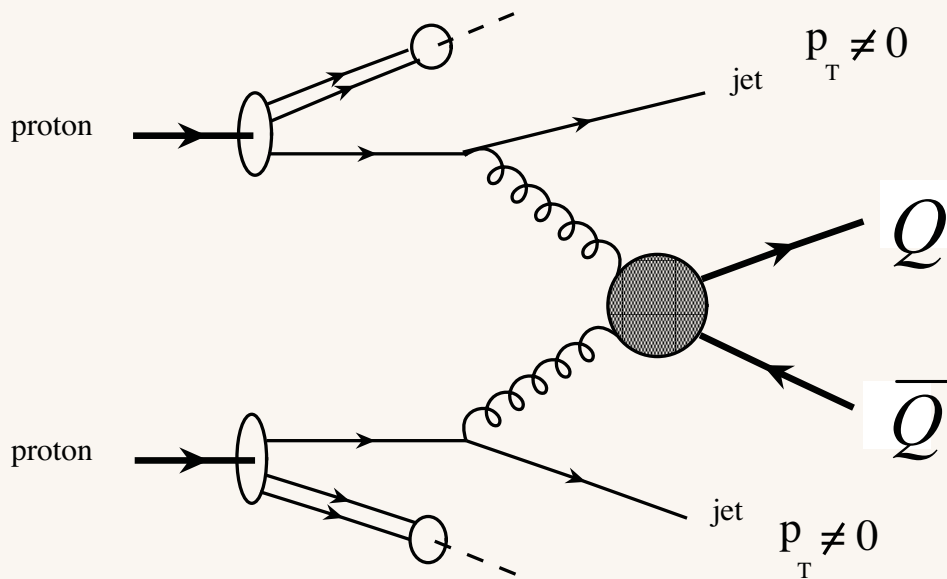

- Preliminary calculation using (massless) results for tree level form factor
- Very low effective scale
➔ much larger cross section than \overline{MS} with scale $\mu_R = M_{Q\bar{Q}}$ or M_Q
- Future : repeat analysis using the full mass-dependent results and include all form factors

Expect that this approach accounts for most of the one-loop corrections

Future Directions

Gauge-invariant four gluon vertex

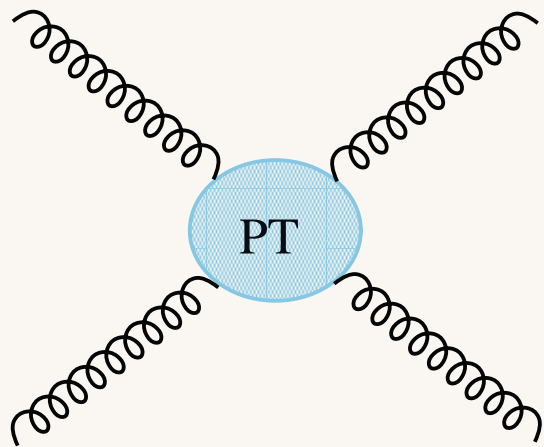

$$L_4(p_1, p_2, p_3, p_4)$$

$$Q_{4\text{eff}}^2(p_1, p_2, p_3, p_4)$$

Hundreds of form factors!

Summary and Future

- ***Multi-scale analytic*** renormalization based on ***physical, gauge-invariant*** Green's functions
- ***Optimal*** improvement of perturbation theory with ***no scale-ambiguity*** since physical kinematic invariants are the arguments of the (multi-scale) couplings

Conventional renormalization scale-setting method:

- Guess arbitrary renormalization scale and take arbitrary range. Wrong for QED and Precision Electroweak.
- Prediction depends on choice of renormalization scheme
- Variation of result with respect to renormalization scale only sensitive to nonconformal terms; no information on genuine (conformal) higher order terms
- Conventional procedure has no scientific basis.
- FAC and PMS give unphysical results.
- Renormalization scale not arbitrary: Analytic constraint from flavor thresholds

Use BLM!

- Satisfies Transitivity, all aspects of Renormalization Group; scheme independent
- Analytic at Flavor Thresholds
- Preserves Underlying Conformal Template
- Physical Interpretation of Scales; Multiple Scales
- Correct Abelian Limit ($N_c = 0$)
- Eliminates unnecessary source of imprecision of PQCD predictions
- Commensurate Scale Relations: Fundamental Tests of QCD free of renormalization scale and scheme ambiguities
- BLM used in many applications, QED, LGTH, BFKL, ...

Factorization scale

$$\mu_{\text{factorization}} \neq \mu_{\text{renormalization}}$$

- Arbitrary separation of soft and hard physics
- Dependence on factorization scale not associated with beta function - present even in conformal theory
- Keep factorization scale separate from renormalization scale $\frac{d\mathcal{O}}{d\mu_{\text{factorization}}} = 0$
- Residual dependence when one works in fixed order in perturbation theory.

Light-Front QCD Phenomenology

- Hidden color, Intrinsic glue, sea, Color Transparency
- Near Conformal Behavior of LFWFs at Short Distances; PQCD constraints
- Vanishing anomalous gravitomagnetic moment
- Relation between edm and anomalous magnetic moment
- Cluster Decomposition Theorem for relativistic systems
- OPE: DGLAP, ERBL evolution; invariant mass scheme

New Perspectives for QCD from AdS/CFT

- LFWFs: Fundamental description of hadrons at amplitude level
- Holographic Model from AdS/CFT : Confinement at large distances and conformal behavior at short distances
- Model for LFWFs, meson and baryon spectra: many applications!
- New basis for diagonalizing Light-Front Hamiltonian
- Physics similar to MIT bag model, but covariant. No problem with support $0 < x < 1$.
- Quark Interchange dominant force at short distances

Essential to test QCD

- J-PARC
- GSI antiprotons
- 12 GeV Jlab
- BaBar/Belle: ISR, two-gamma, timelike DVCS
- RHIC/LHC Nuclear Collisions; LHCb
- electron-proton, electron-nucleus collisions

Novel Tests of QCD at GSI

Polarized antiproton Beam Secondary Beams

- Characteristic momentum scale of QCD: 300 MeV
- Many Tests of AdS/CFT predictions possible
- Exclusive channels: Conformal scaling laws, quark-interchange
- $\bar{p}p$ scattering: fundamental aspects of nuclear force
- Color transparency: Coherent color effects
- Nuclear Effects, Hidden Color, Anti-Shadowing
- Anomalous heavy quark phenomena
- Spin Effects: A_N, A_{NN}

QCD Phenomenology and Nucleon Structure



Thanks to Adam and Steve!



National Nuclear Physics Summer School