

Key QCD Experiment at J-PARC

Double-Diffractive Drell-Yan

$$pp \rightarrow p + \ell^+ \ell^- + p$$

Large-Mass Timelike Muon Pairs in Hadronic Interactions

S. M. Berman*, D. J. Levy, and T. L. Neff§

Phys. Rev. Lett. 23, 1363–1365 (1969)

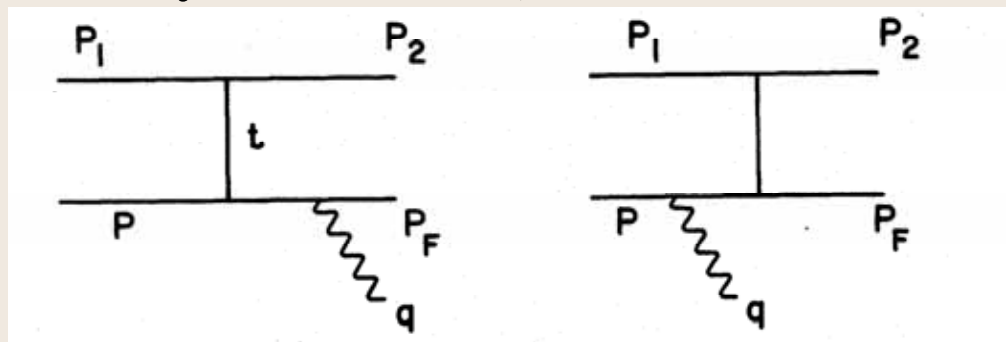

Prototype for exclusive Higgs production

Key QCD Experiment at J-PARC

Measure diffractive hidden charm production
at forward x_F

$$\frac{d\sigma}{dt_1 dt_2 dx_F} (pp \rightarrow p + J/\psi + p)$$

$$\frac{d\sigma}{dt dx_F} (pp \rightarrow p + J/\psi + X)$$

Anomalous nuclear dependence

$$\frac{d\sigma}{dx_F} (pA \rightarrow J/\psi + X)$$

$A^{\alpha(x_2)}$ versus $A^{\alpha(x_F)}$

Important Tests of Intrinsic Charm

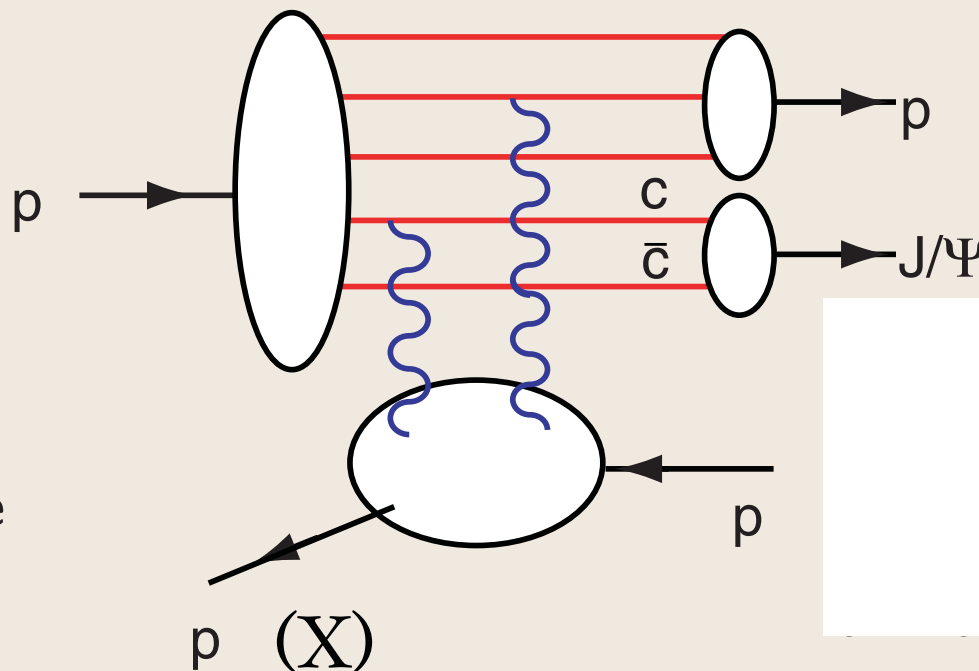

$$|p, S_z\rangle = \sum_{n=3} \Psi_n(x_i, \vec{k}_{\perp i}, \lambda_i) |n; \vec{k}_{\perp i}, \lambda_i\rangle$$

The Light Front Fock State Wavefunctions

$$\Psi_n(x_i, \vec{k}_{\perp i}, \lambda_i)$$

are boost invariant; they are independent of the hadron's energy and momentum P^μ .

The light-cone momentum fraction

$$x_i = \frac{k_i^+}{p^+} = \frac{k_i^0 + k_i^z}{P^0 + P^z}$$

are boost invariant.

$$\sum_i^n k_i^+ = P^+, \quad \sum_i^n x_i = 1, \quad \sum_i^n \vec{k}_i^\perp = \vec{0}^\perp.$$

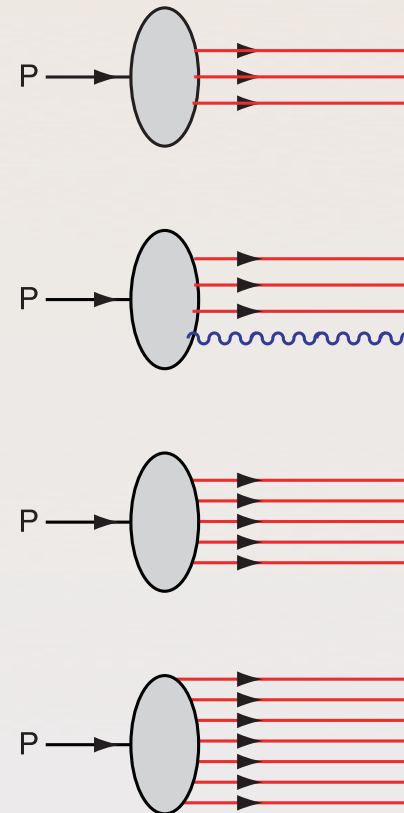

Hadrons Fluctuate in Particle Number

- Proton Fock States

$$|uud\rangle, |uudg\rangle, |uuds\bar{s}\rangle, |uudc\bar{c}\rangle, |uudb\bar{b}\rangle \dots$$

- Strange and Anti-Strange Quarks not Symmetric

$$s(x) \neq \bar{s}(x)$$

- “**Intrinsic Charm**”: High momentum heavy quarks
- “**Hidden Color**”: Deuteron not always $p + n$
- Orbital Angular Momentum Fluctuations - Anomalous Magnetic Moment

Novel Tests of QCD
at J-PARC

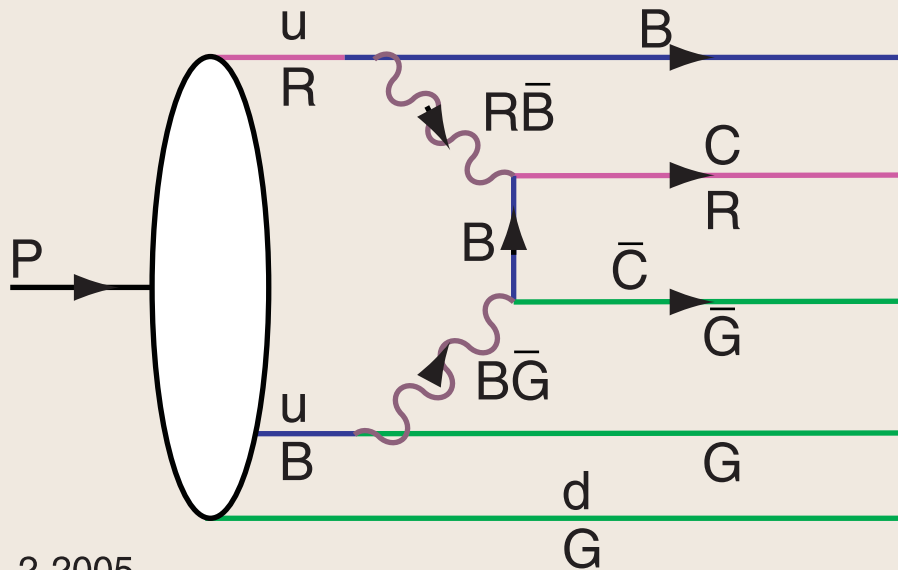

$|uudc\bar{c}\rangle$ Fluctuation in Proton
 QCD: Probability $\sim \frac{\Lambda_{QCD}^2}{M_Q^2}$

OPE derivation - M.Polyakov et al.
 $c\bar{c}$ in Color Octet

High x charm

Distribution peaks at equal rapidity (velocity)
 Therefore heavy particles carry the largest momentum fractions

In contrast:

$|e^+e^-\ell^+\ell^-\rangle$ Fluctuation in Positronium
 QED: Probability $\sim \frac{(m_e\alpha)^4}{M_\ell^4}$

Novel Tests of QCD
 at J-PARC

Measure $c(x)$ in Deep Inelastic Lepton-Proton Scattering

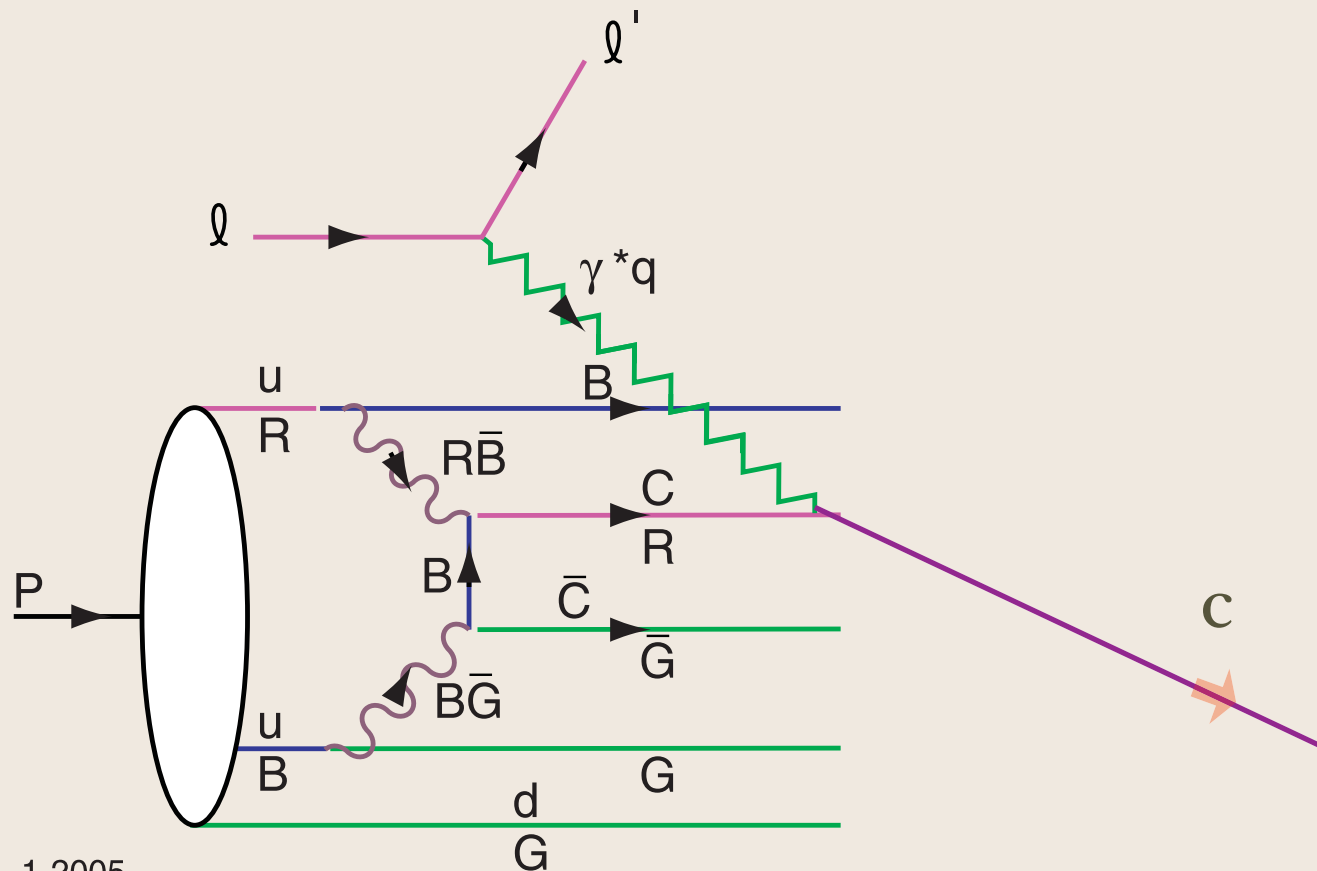

1-2005
8711A83

Hoyer, Peterson, SJB

Novel Tests of QCD
at J-PARC

Stan Brodsky, SLAC

KEK
II-30-05

Measurement of Charm Structure Function

Evidence for Intrinsic Charm

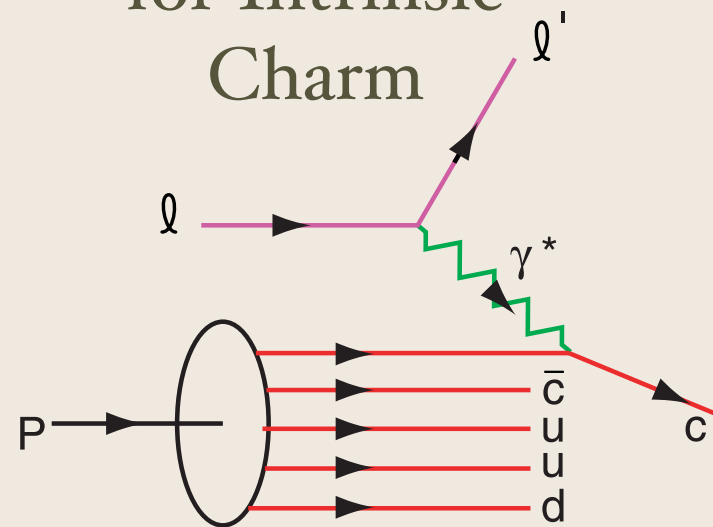

1-2005
8711A59

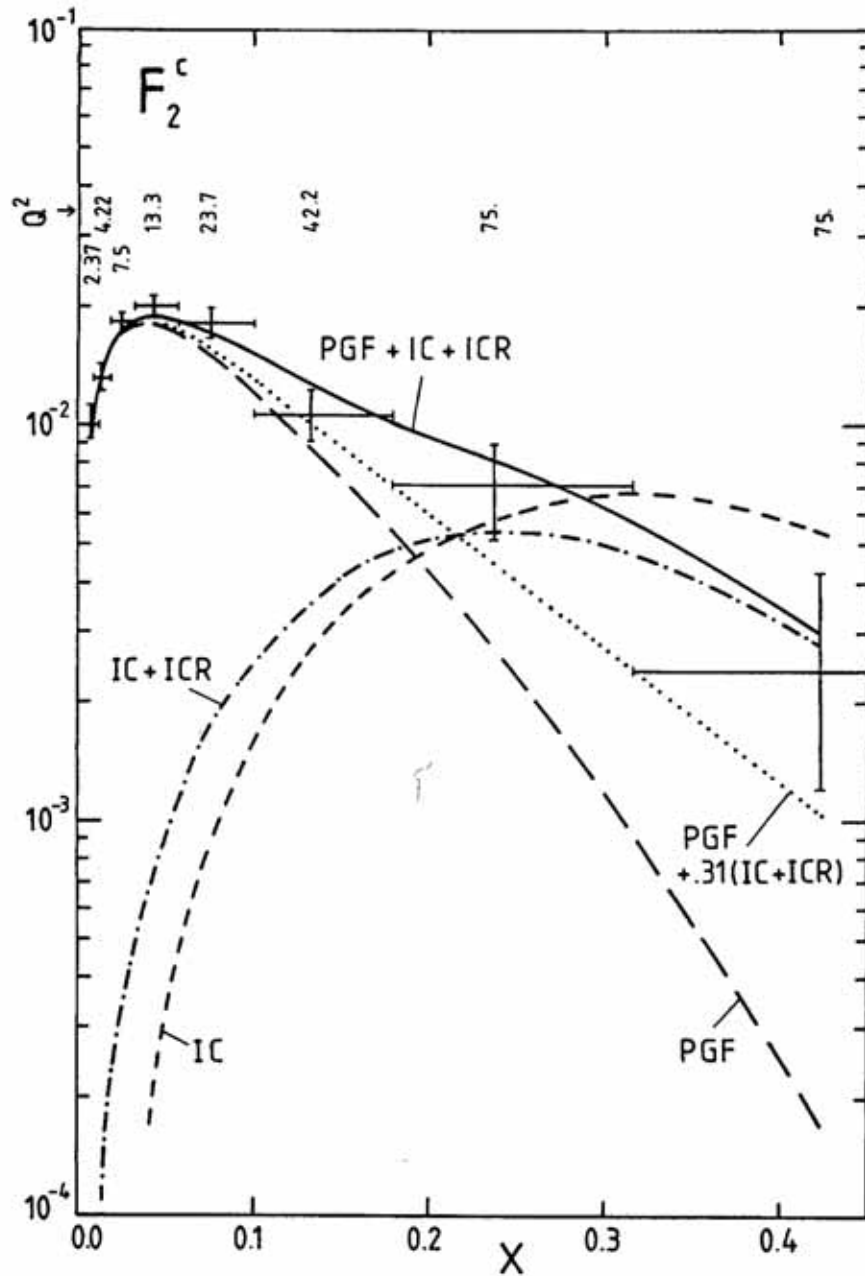

J. J. Aubert et al. [European Muon Collaboration], "Production Of Charmed Particles In 250-GeV μ^+ - Iron Interactions," Nucl. Phys. B **213**, 31 (1983).

Stan Brodsky, SLAC

KEK
II-30-05

EMC Measurements of the Charm Structure Function

Photon Gluon Fusion Factor 30 too small !

J. J. Aubert et al. [European Muon Collaboration], "Production Of Charmed Particles In 250-GeV μ^+ - Iron Interactions," Nucl. Phys. B 213, 31 (1983).

1% IC

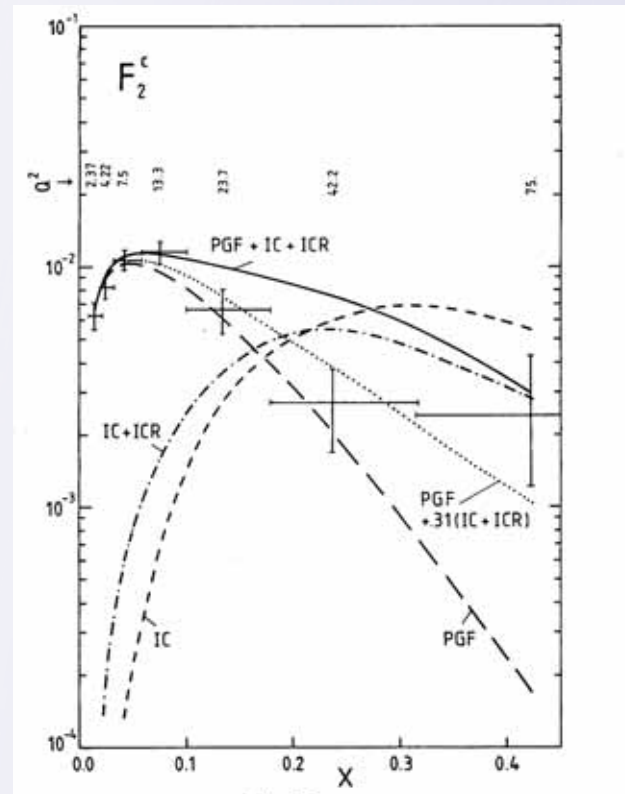
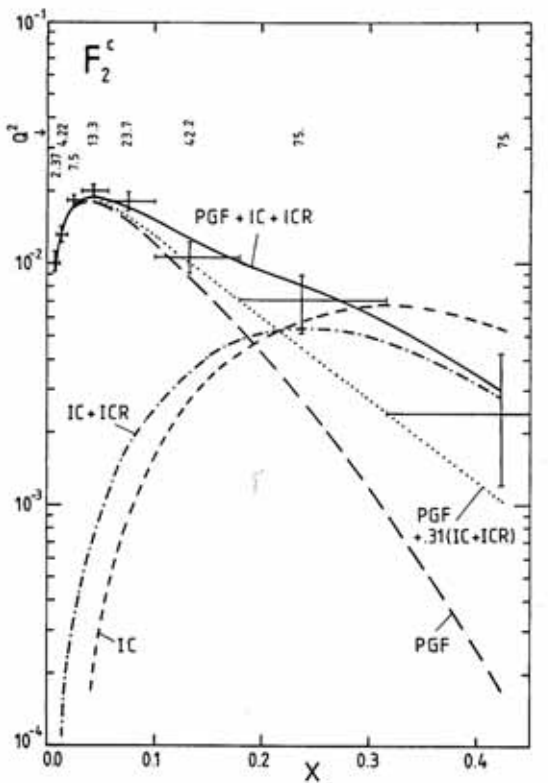

Analysis by

E. Hoffmann and R. Moore, Z. Phys. C 20, 71 (1983).

Novel Tests of QCD

at J-PARC

108

KEK
II-30-05

Stan Brodsky, SLAC

- EMC data: $c(x, Q^2) > 30 \times \text{DGLAP}$
 $Q^2 = 75 \text{ GeV}^2, x = 0.42$
- High x_F $pp \rightarrow J/\psi X$ NA3
- High x_F $pp \rightarrow J/\psi J/\psi X$ NA3
- High x_F $pp \rightarrow \Lambda_c X$ ISR
- High x_F $pp \rightarrow \Lambda_b X$ ISR
- High x_F $pp \rightarrow \Xi(ccd) X$ (SELEX)

Key QCD Experiment at J-PARC

Diffractive Dissociation of Intrinsic Charm

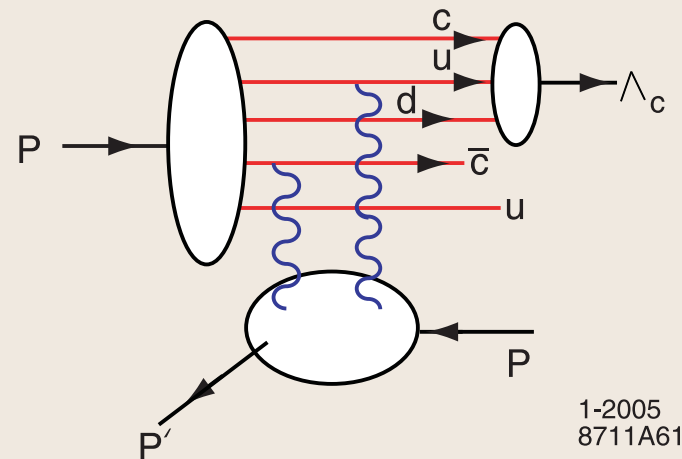
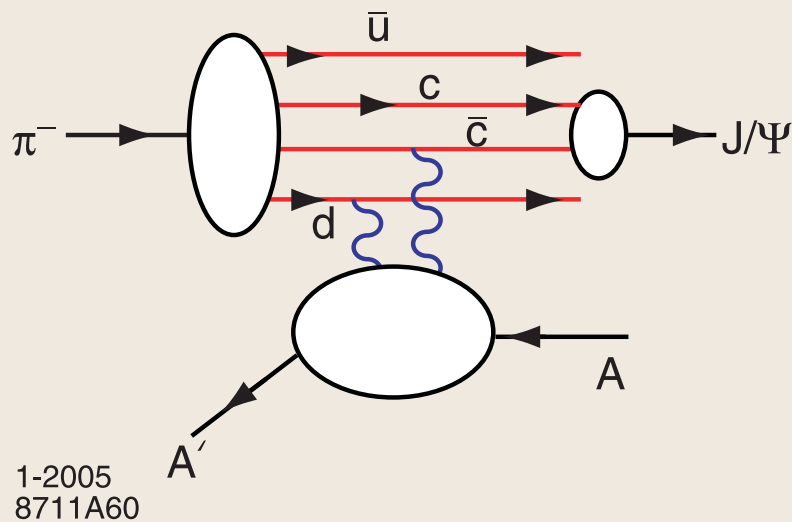

Coalescence of Comoving Charm and Valence Quarks
Produce J/ψ , Λ_c and other Charm Hadrons at High x_F

$$p p \rightarrow p \Lambda_c X$$

Diffractive Dissociation of Intrinsic Charm

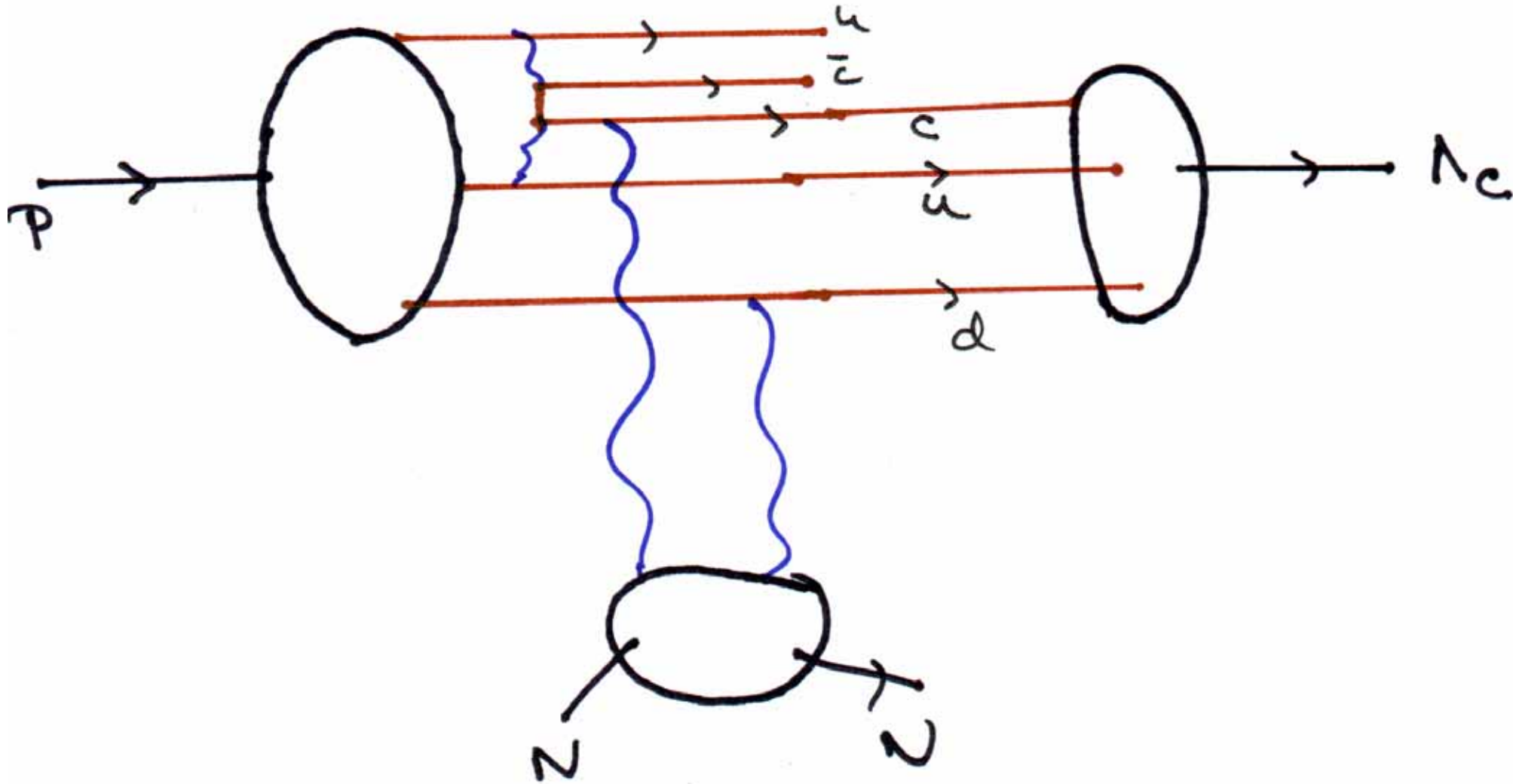

Production of Charm Hadrons at the ISR

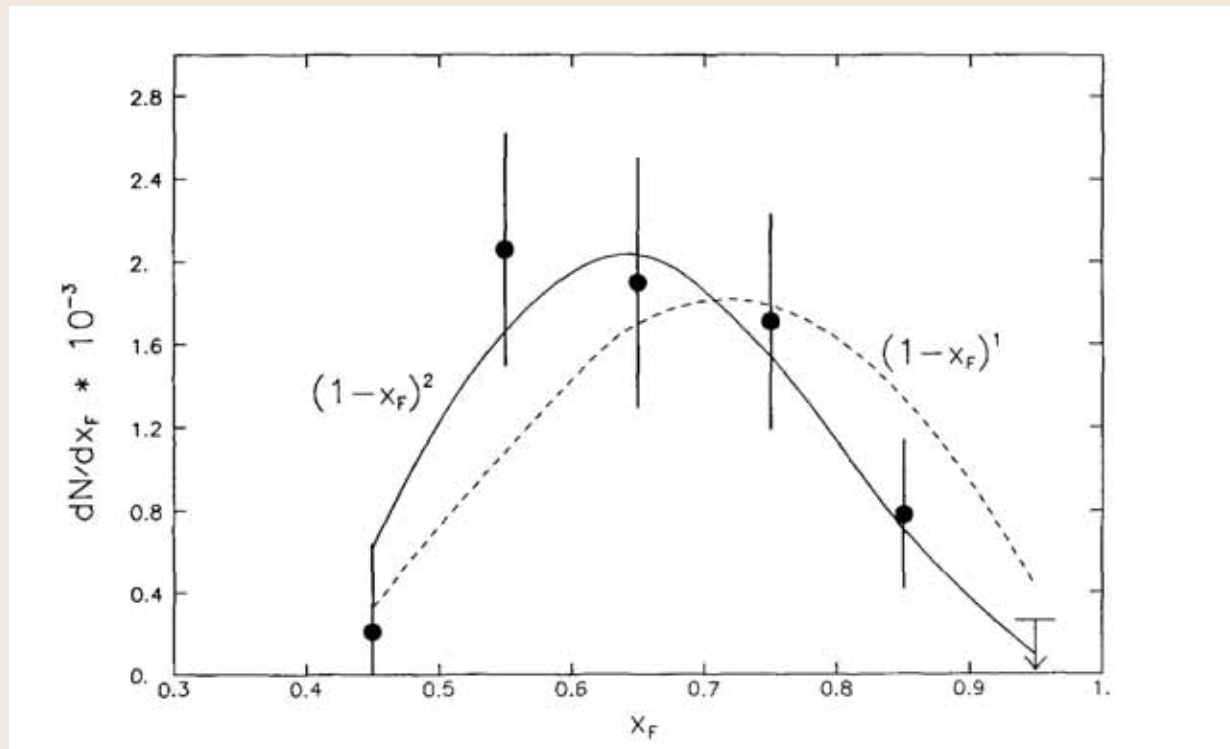

P. M. Chauvat et al. [R608 Collaboration],
“Production of Λ_C With Large x_F At The ISR,”
Phys. Lett. B 199, 304 (1987).

$pp \rightarrow p\Lambda_C X$

KEK
II-30-05

Novel Tests of QCD
at J-PARC

II2

Stan Brodsky, SLAC

Key QCD Experiment at J-PARC

Measure diffractive open charm production at forward x_F

$$\frac{d\sigma}{dt dx_F}(pp \rightarrow p + \Lambda_C + X)$$

$$\mathcal{M}^2 \geq 16 \text{ GeV}^2$$

$$s = 80 \text{ GeV}^2$$

$$\Delta p_L = \frac{\mathcal{M}^2 - 1 \text{ GeV}^2}{2E_{lab}} \geq 0.4 \text{ GeV}$$

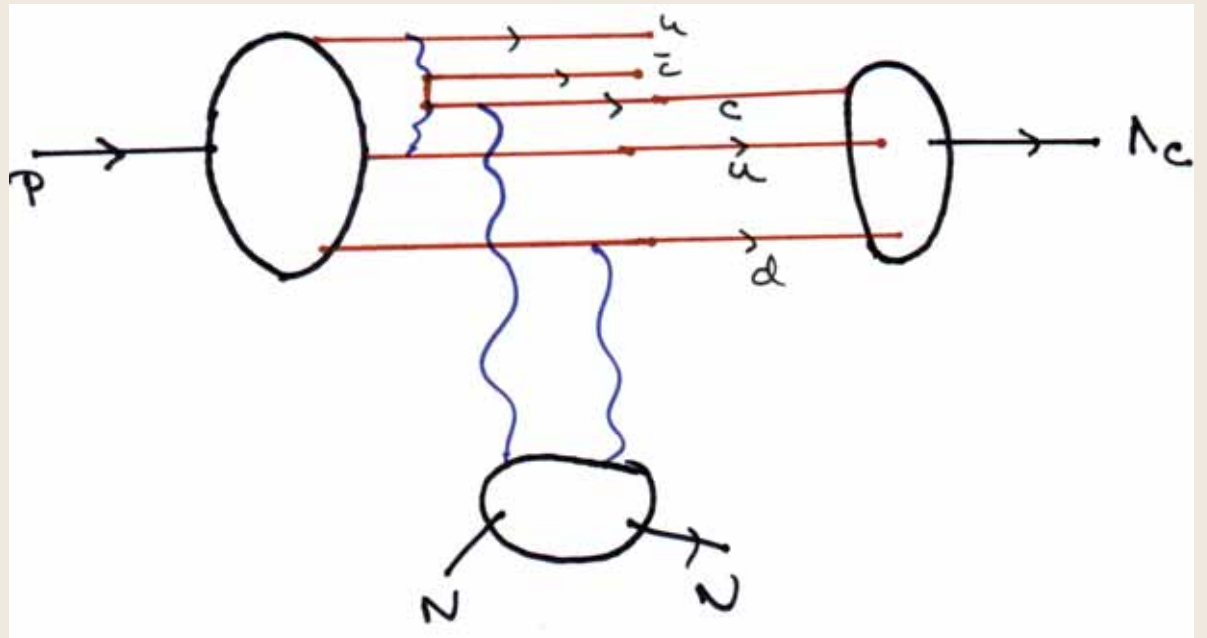

Important Test of Intrinsic Charm

$$\pi A \rightarrow J/\psi J/\psi X$$

Intrinsic charm contribution to double quarkonium hadroproduction^{*}

R. Vogt^a, S.J. Brodsky^b

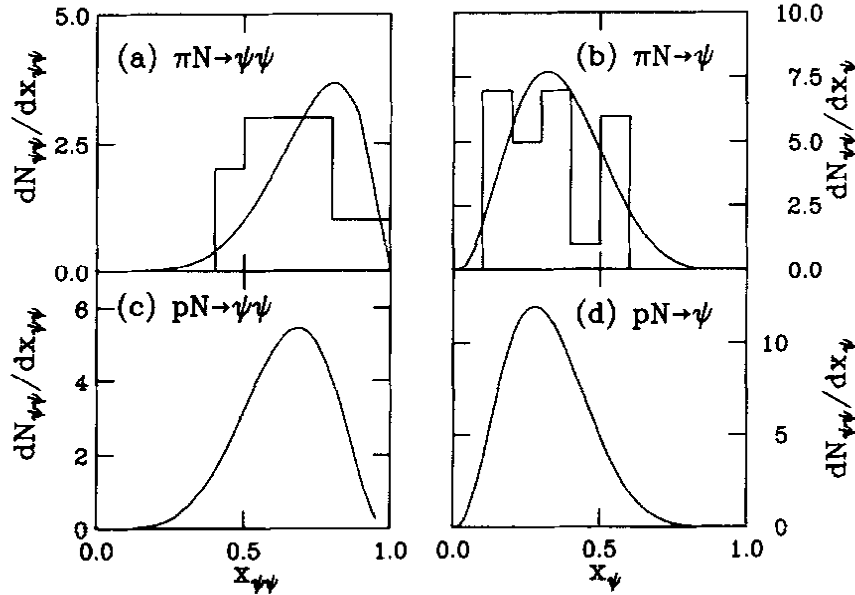
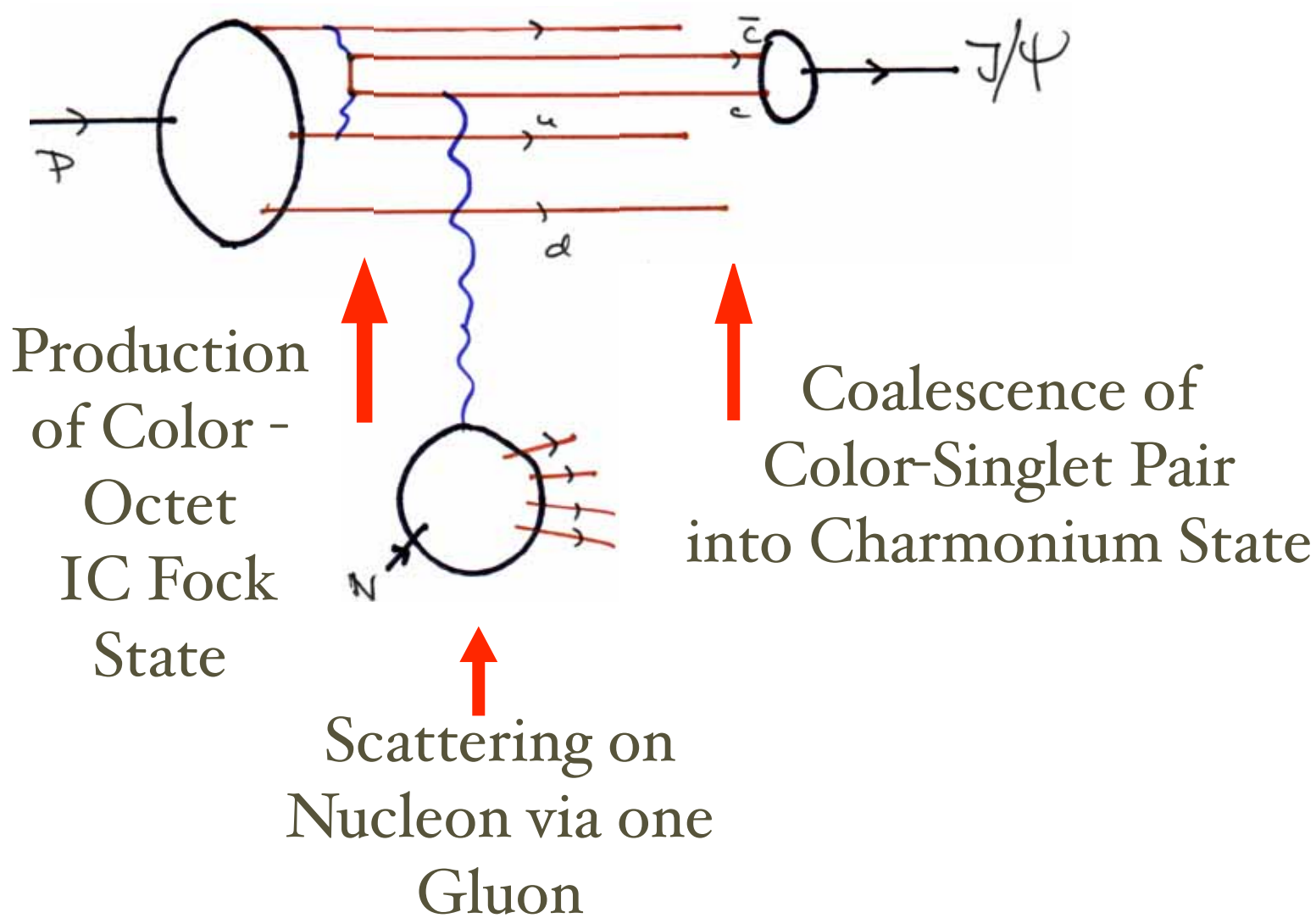

Fig. 3. The $\psi\psi$ pair distributions are shown in (a) and (c) for the pion and proton projectiles. Similarly, the distributions of J/ψ 's from the pairs are shown in (b) and (d). Our calculations are compared with the π^-N data at 150 and 280 GeV/c [1]. The $x_{\psi\psi}$ distributions are normalized to the number of pairs from both pion beams (a) and the number of pairs from the 400 GeV proton measurement (c). The number of single J/ψ 's is twice the number of pairs.

NA3 Data

The probability distribution for a general n -parton intrinsic $c\bar{c}$ Fock state as a function of x and k_T written as

$$\frac{dP_{ic}}{\prod_{i=1}^n dx_i d^2k_{T,i}} = N_n \alpha_s^4 (M_{c\bar{c}}) \frac{\delta(\sum_{i=1}^n k_{T,i}) \delta(1 - \sum_{i=1}^n x_i)}{(m_h^2 - \sum_{i=1}^n (m_{T,i}^2/x_i))^2},$$



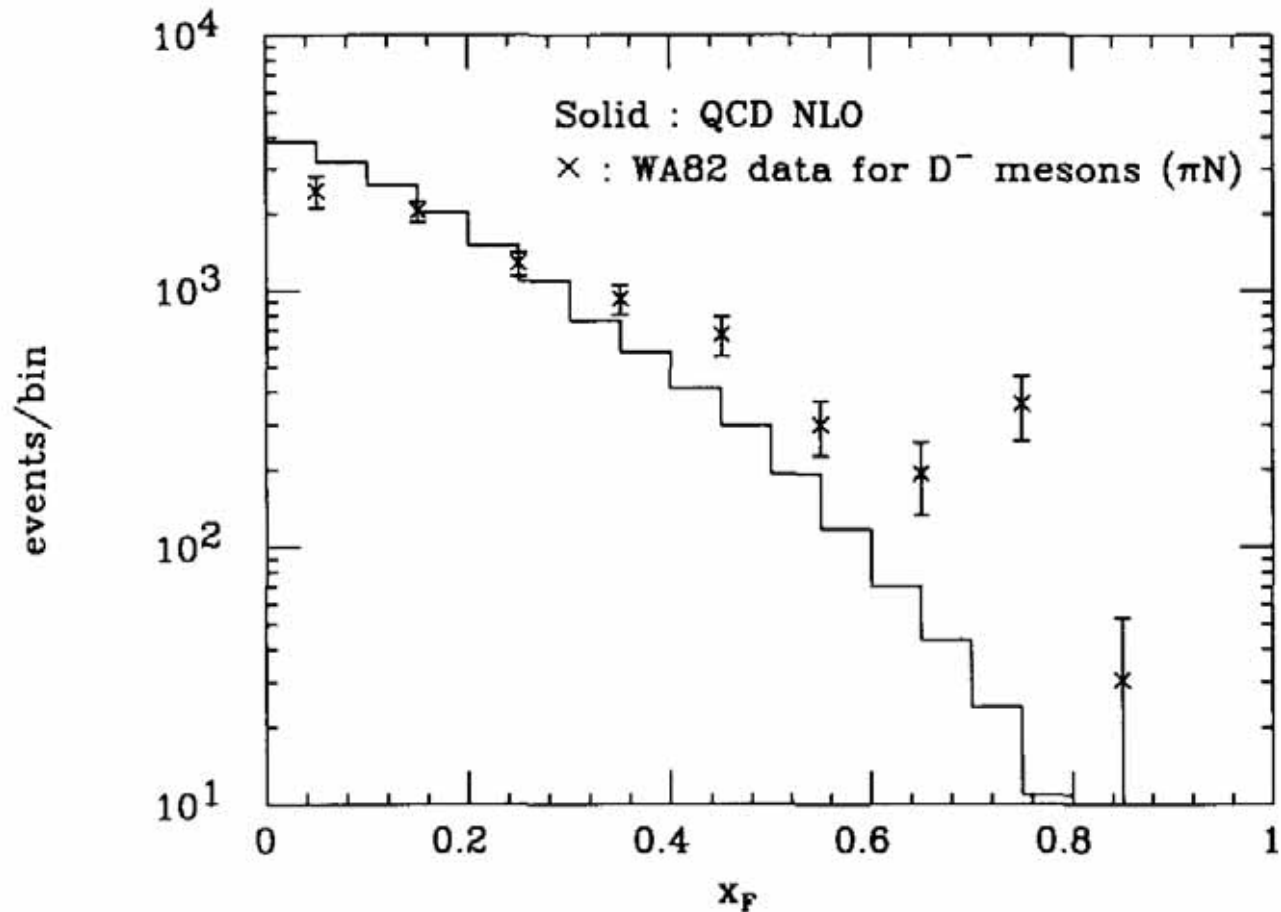

S. Frixione, M. L. Mangano, P. Nason and G. Ridolfi, “Heavy-Quark Production,”
 Adv. Ser. Direct. High Energy Phys. 15, 609
 (1998) [arXiv:hep-ph/9702287].

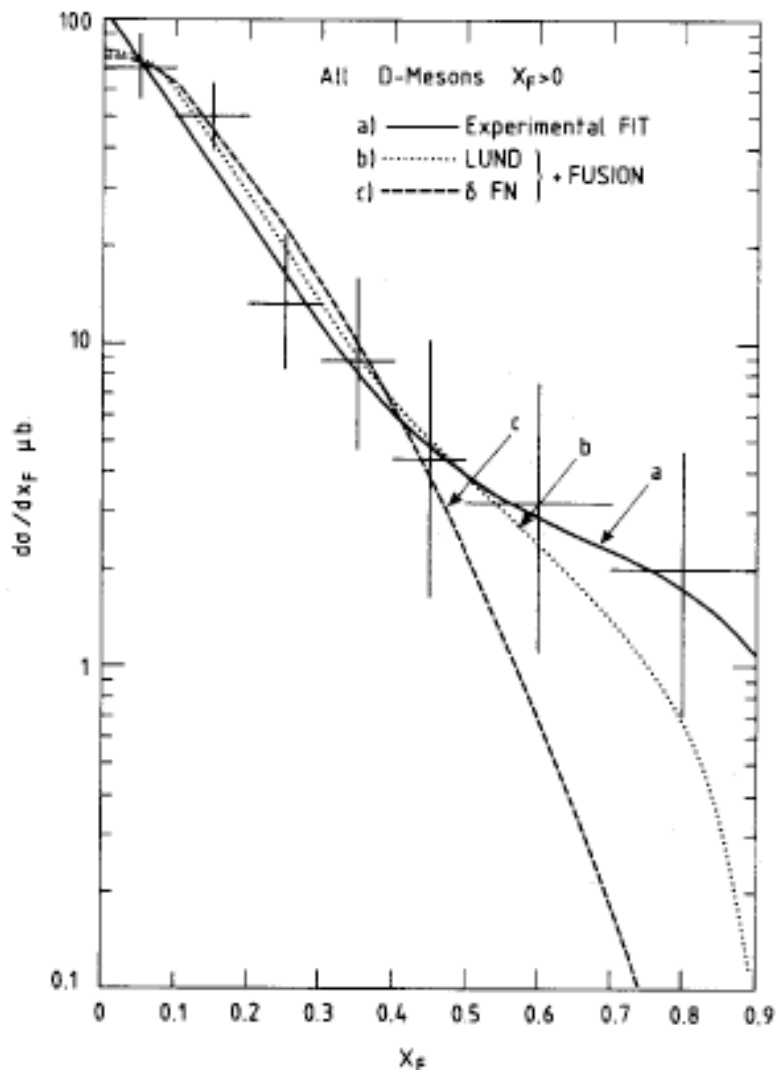

Fig. 1. The differential distribution x_F for all D mesons having $x_F > 0$. Curve (a) is the two-component fit to the data as described in the text. Curve (b) is the prediction of the Lund fusion calculation. Curve (c) is the prediction of the bare QCD fusion calculation (δ -function fragmentation). Note that both theoretical curves have been normalised to the observed total cross section for $x_F > 0$.

M. Aguilar-Benitez et al.
 [NA27 Collaboration],
 “Inclusive Properties Of *D* Mesons
 Produced In 360-GeV πp Interaction
 Phys. Lett. B 161, 400 (1985).

- IC Explains Anomalous $\alpha(x_F)$ not $\alpha(x_2)$ dependence of $pA \rightarrow J/\psi X$
(Mueller, Gunion, Tang, SJB)
- Color Octet IC Explains $A^{2/3}$ behavior at high x_F (NA3, Fermilab)
(Kopeliovitch, Schmidt, Soffer, SJB)
- IC Explains $J/\psi \rightarrow \rho\pi$ puzzle
(Karliner, SJB)
- IC leads to new effects in B decay
(Gardner, SJB)

Key QCD Experiment at J-PARC

Measure diffractive hidden charm production
at forward x_F

$$\frac{d\sigma}{dt_1 dt_2 dx_F} (pp \rightarrow p + J/\psi + p)$$

$$\frac{d\sigma}{dt dx_F} (pp \rightarrow p + J/\psi + X)$$

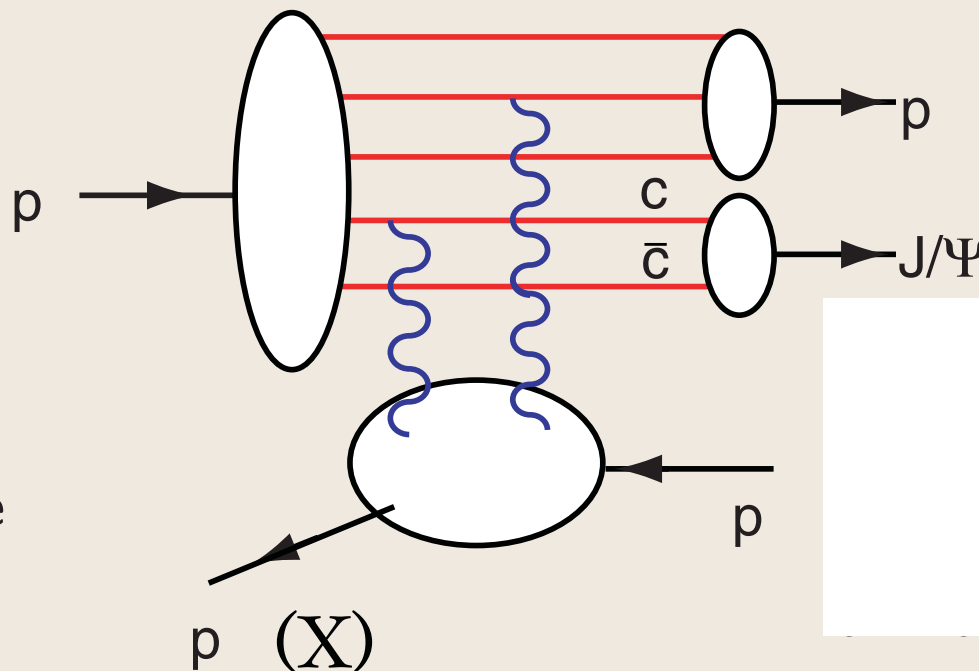

Anomalous nuclear dependence

$$\frac{d\sigma}{dx_F} (pA \rightarrow J/\psi + X)$$

$$A^{\alpha(x_2)} \text{ versus } A^{\alpha(x_F)}$$

Important Tests of Intrinsic Charm

Key QCD Experiment at J-PARC

Intrinsic Charm Mechanism for Double Diffraction

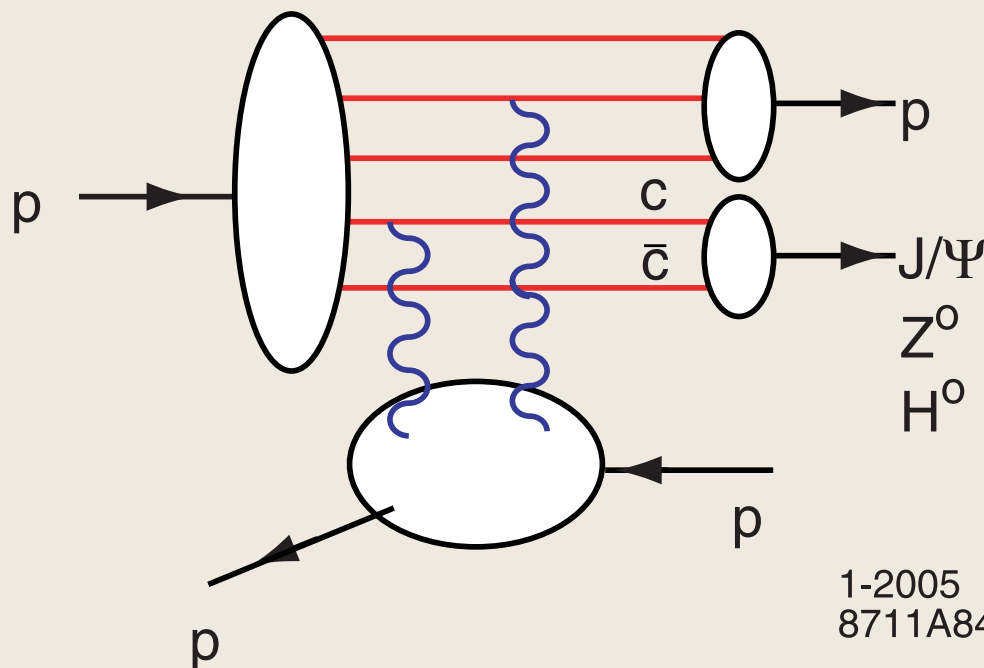

$$p p \rightarrow J/\psi p p$$

$$x_{J/\psi} = x_c + x_{\bar{c}}$$

High x_F !

Kopeliovitch, Schmidt, Soffer, sjb

Possible J-PARC
experiment

Intrinsic $c\bar{c}$ pair formed in color octet 8_C in proton wavefunction Large Color Dipole

Collision produces color-singlet J/ψ through color exchange

Production of Two Charmonia at High x_F

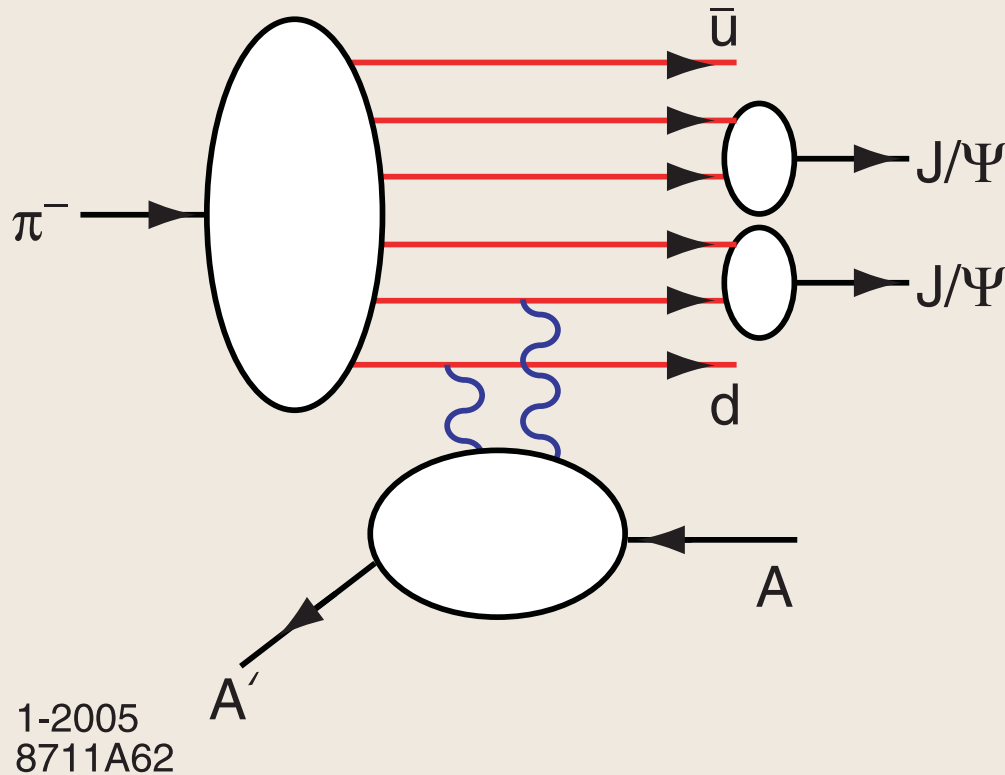

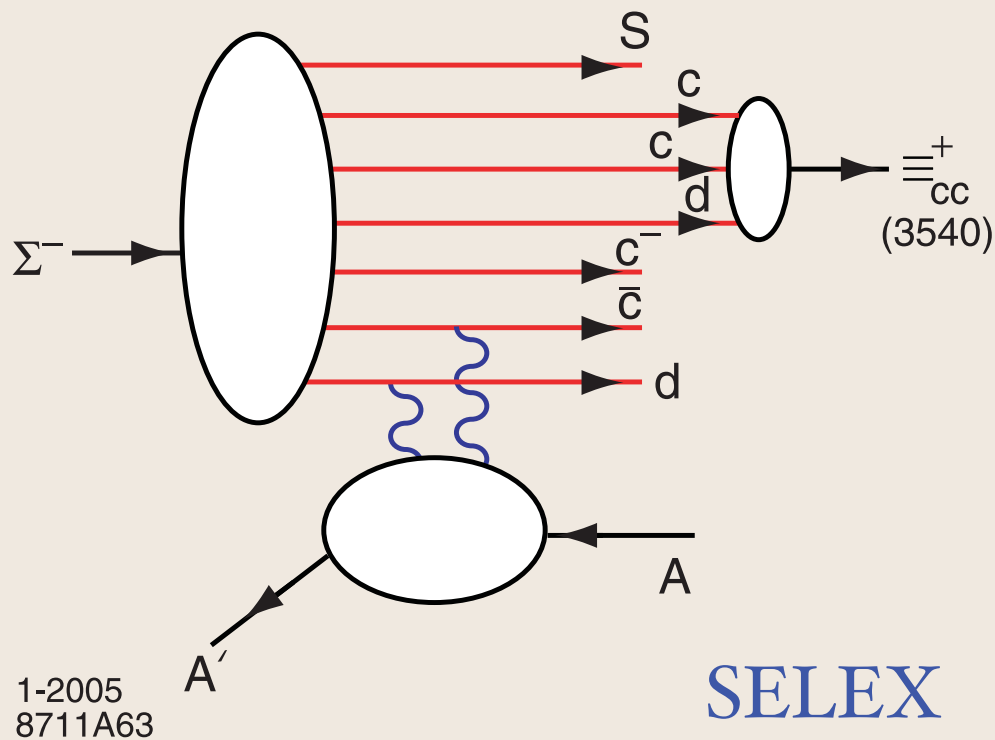

Production of a Double-Charm Baryon

Nuclear Dependence of Quarkonium Production

NA3 data for $\frac{d\sigma}{dx_F}(p(\pi)A \rightarrow J/\psi X)$: hard A^1 and “diffractive” $A^{2/3}$ components

Diffractive contribution extends to large x_F

$A^{\alpha(x_F)}$ not $A^{\alpha(x_2)}$: PQCD Factorization Violated!

NA3 COLLABORATION

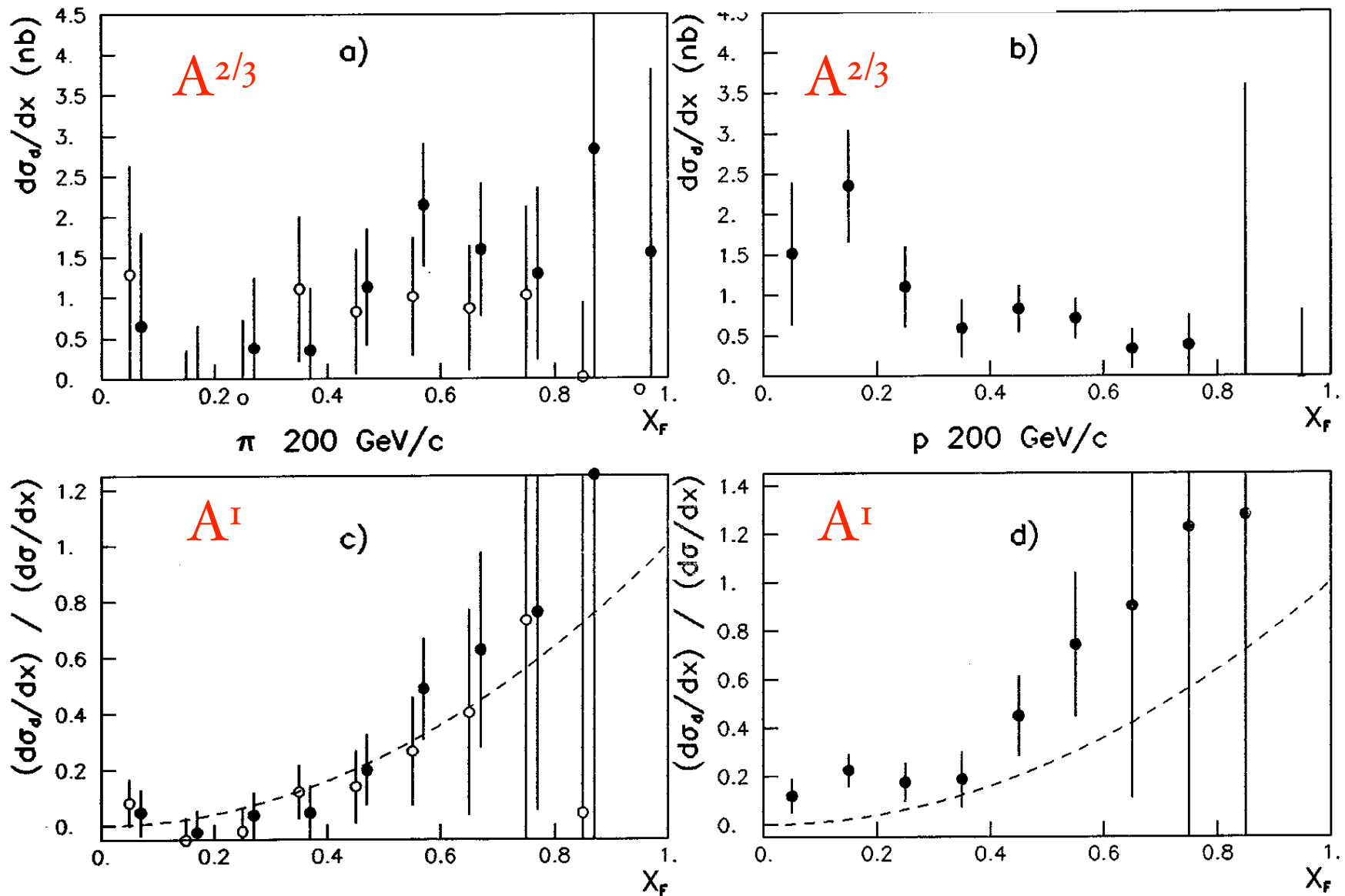

800 GeV p-A (FNAL) $\sigma_A = \sigma_p * A^\alpha$
PRL 84, 3256 (2000); PRL 72, 2542 (1994)

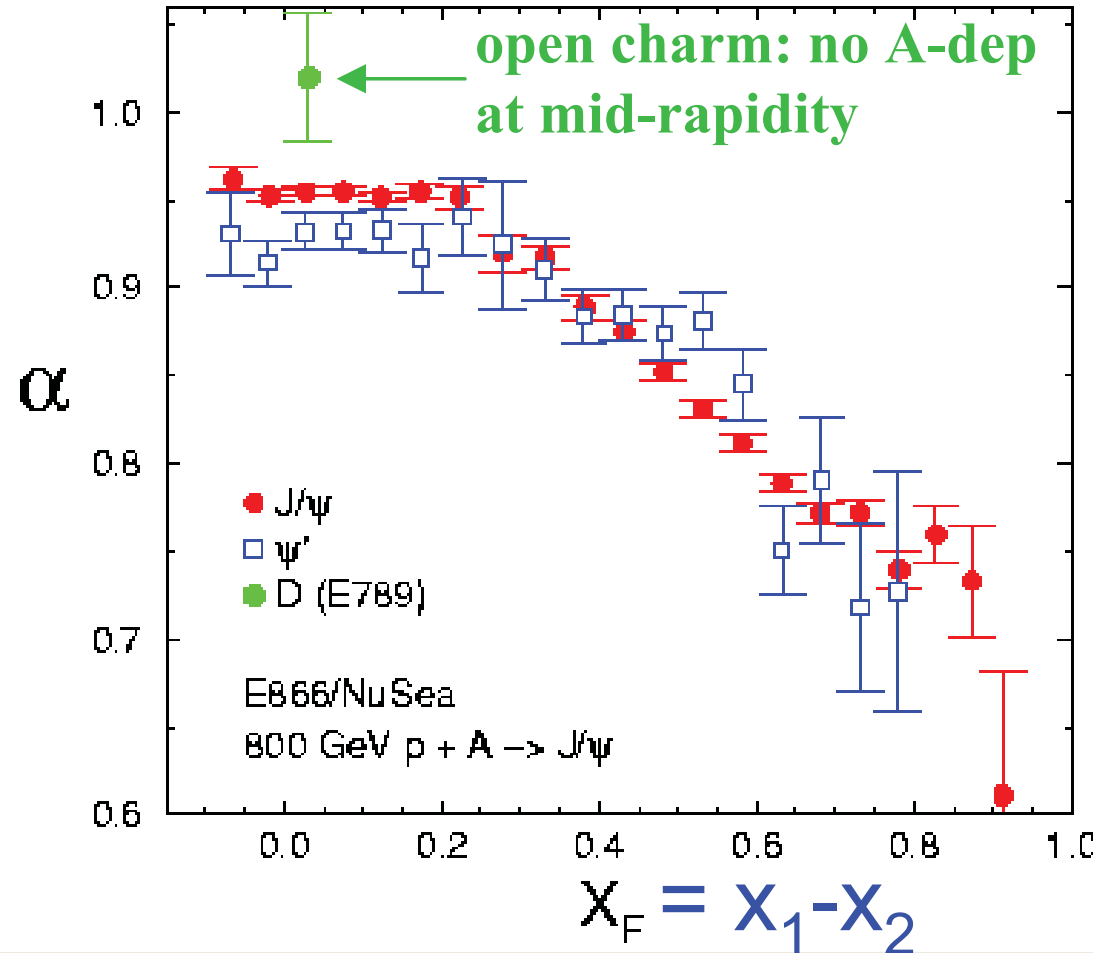

Remarkably Strong Nuclear
 Dependence for Fast
 Charmonium

M. Leitch

Nuclear effects in Quarkonium production

$p + A$ at $s^{1/2} = 38.8$ GeV

$$\sigma(p+A) = A^\alpha \sigma(p+N)$$

E772 data

Strong x_F - dependence

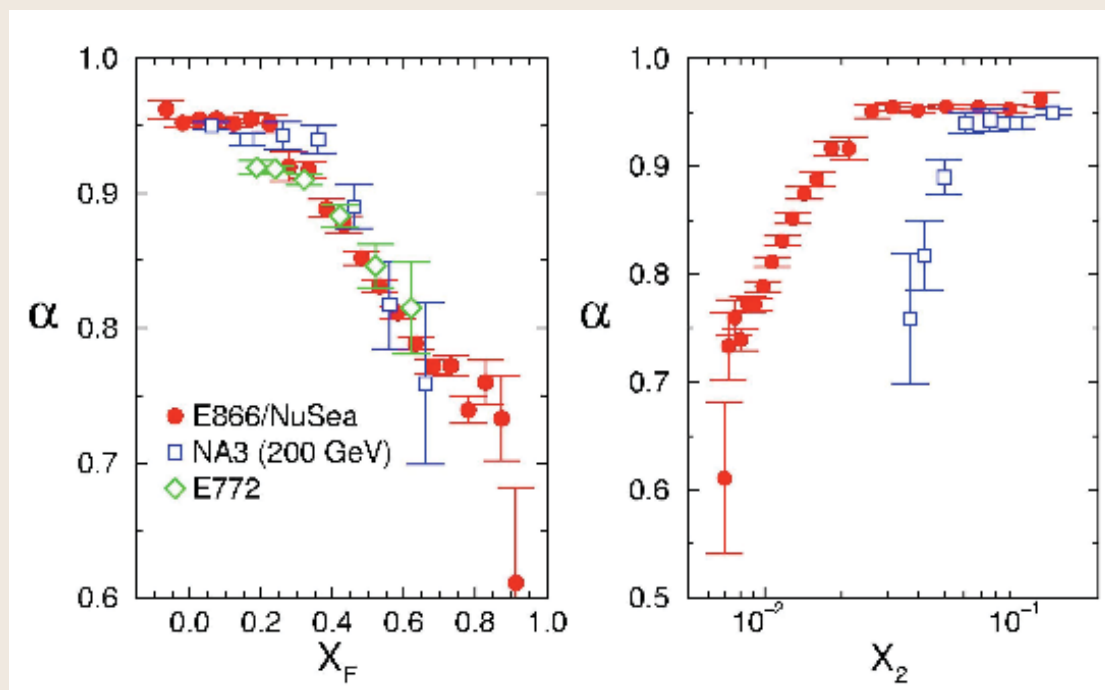
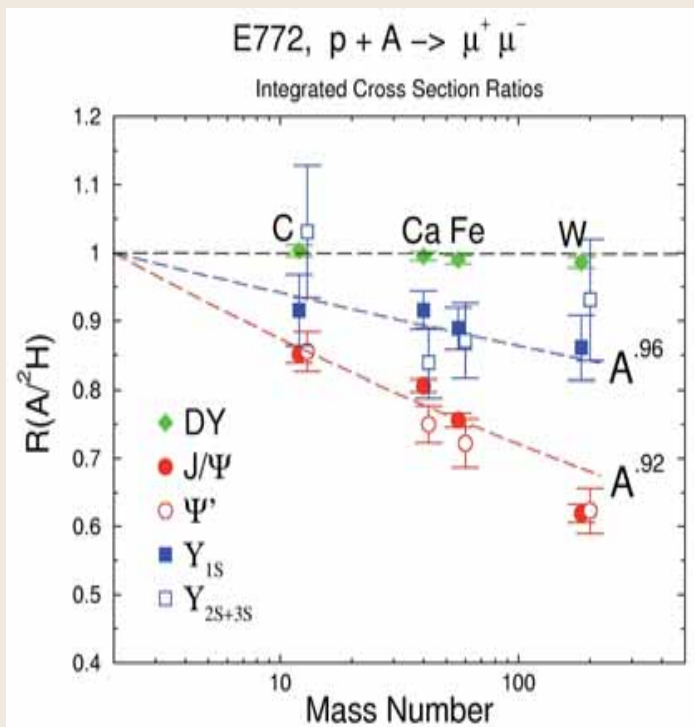

Nuclear effects scale with x_F , not x_2 !!!

M. Leitch

800 GeV p + A -> J/ψ

E866/NuSea Preliminary, $\sigma_A = \sigma_p * A^\alpha$

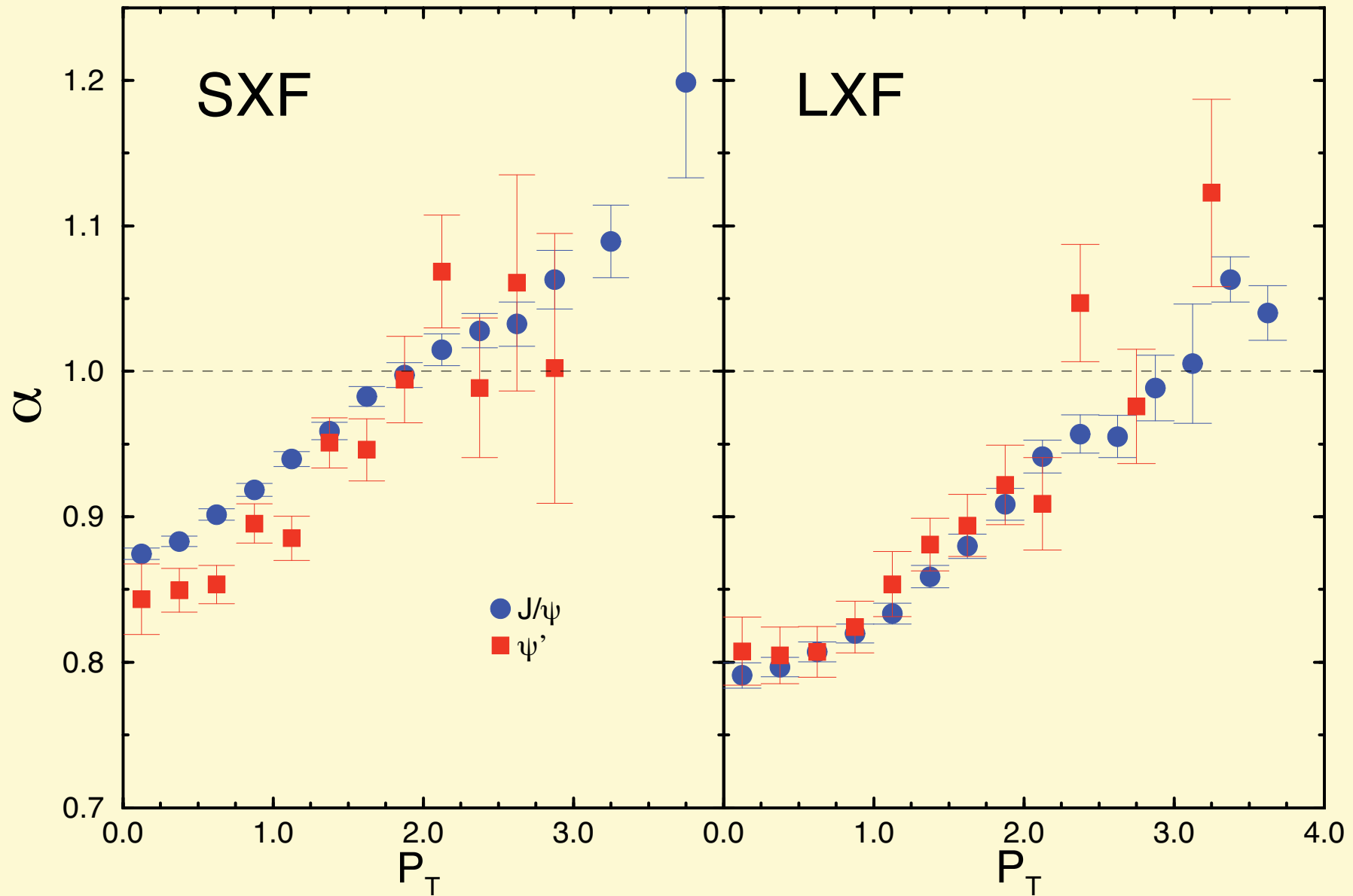

Key QCD Experiment at J-PARC

Measure Nuclear Dependence of $J/\psi, \eta_c$
open charm production production

Understand breakdown
of QCD Factorization

Intrinsic Charm, Color Octet Dipole Physics,
Energy Loss Mechanisms

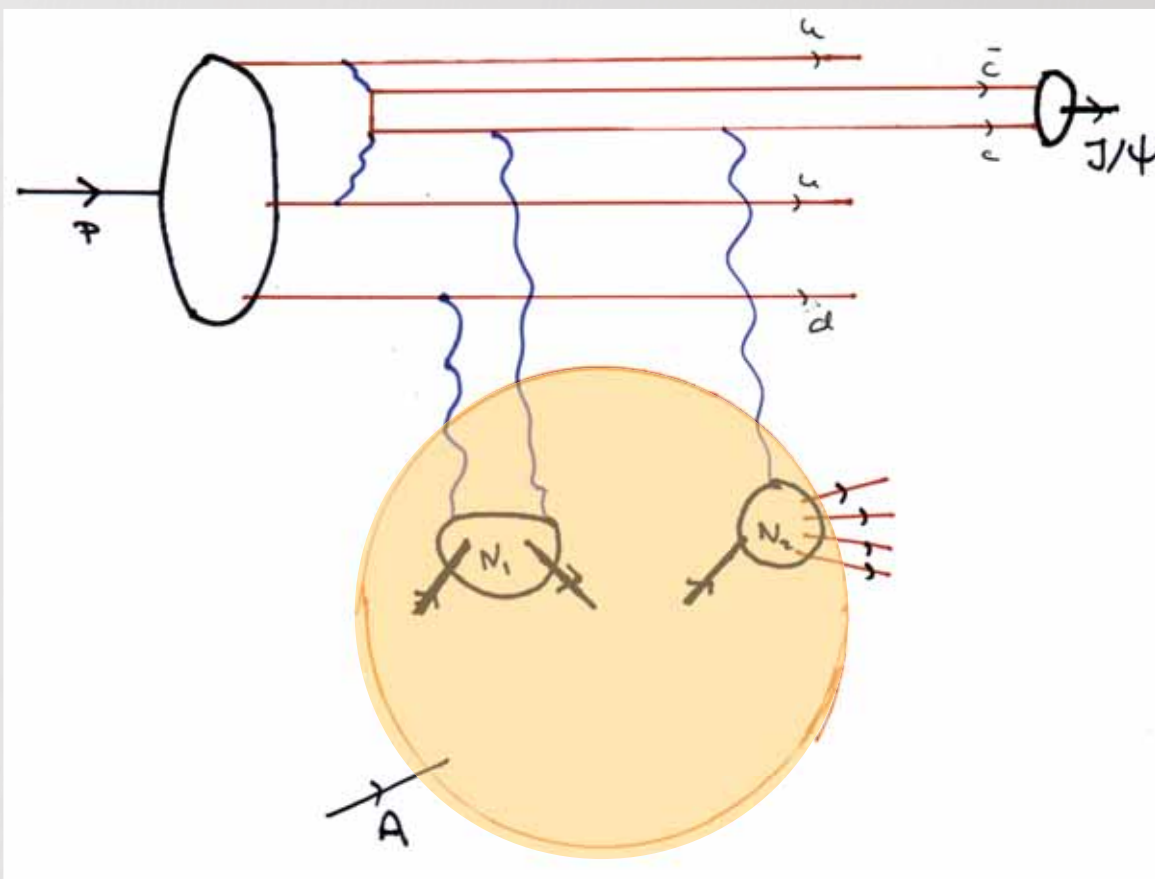

Shadowing of $pA \rightarrow J/\Psi X$

J/Ψ Production on Front Surface
No Absorption of Propagating J/Ψ

$$\sigma(p + A \rightarrow J/\Psi + X) \propto A^{2/3}$$

Elastic scattering of IC Fock state:

$$|[uud]_{8_c}[c\bar{c}]_{8_c} \rangle + N_1 \rightarrow |[uud]_{8_c}[c\bar{c}]_{8_c} \rangle + N_1$$

followed by:

$$|[uud]_{8_c}[c\bar{c}]_{8_c} \rangle + N_2 \rightarrow J/\Psi + X$$

Depleted flux on downstream nucleons

Key QCD Experiment at J-PARC

Measure nuclear shadowing, antishadowing at J-PARC in Drell-Yan reactions

$$pA \rightarrow \ell^+ \ell^- X$$

$$Q^2 = x_1 x_2 s \quad x_1 x_2 = .05, x_F = x_1 - x_2$$

$$A^\alpha(x_1) = \frac{2 \frac{d\sigma}{dQ^2 dx_F}(pA \rightarrow \ell^+ \ell^- X)}{A \frac{d\sigma}{dQ^2 dx_F}(pd \rightarrow \ell^+ \ell^- X)}$$

Higher twist effects at high x_F :

Deviations from $(1 + \cos^2 \theta)$

$\cos 2\phi$ correlation.

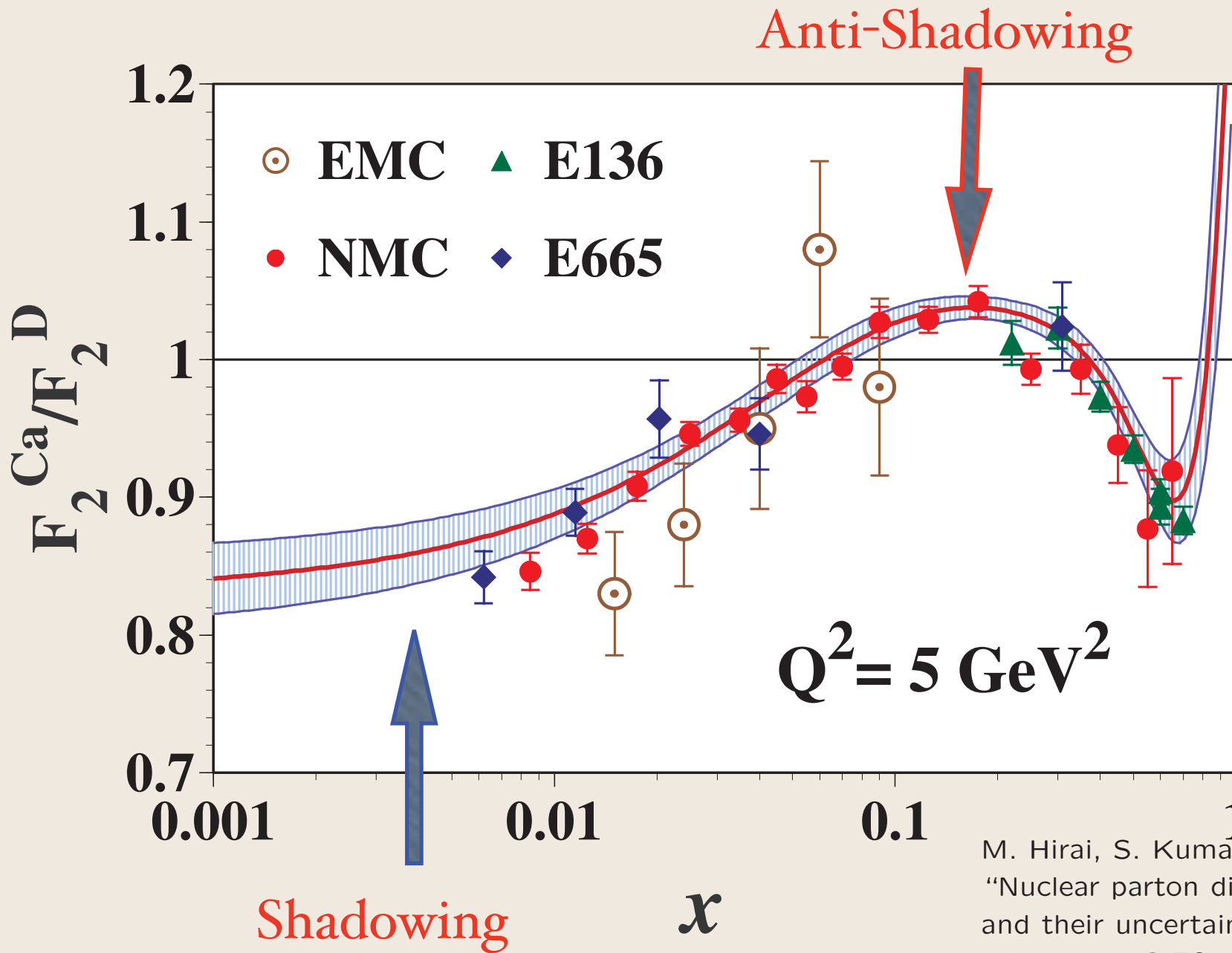

M. Hirai, S. Kumano and T. H. Nagai,
 "Nuclear parton distribution functions
 and their uncertainties,"
 Phys. Rev. C **70**, 044905 (2004)
 [arXiv:hep-ph/0404093].

Origin of Nuclear Shadowing in Glauber - Gribov Theory

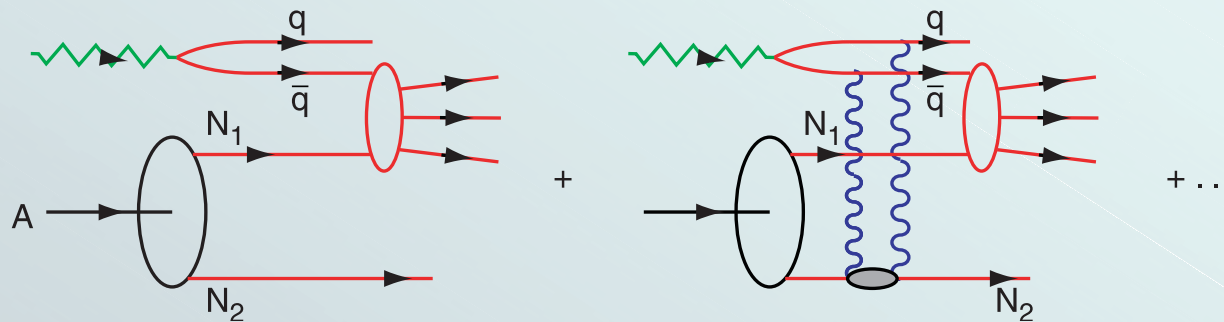

Interference of one-step and two-step processes
 Interaction on upstream nucleon diffractive
 Phase $i \times i = -1$ produces destructive interference
 No Flux reaches down stream nucleon

Nuclear Shadowing in QCD

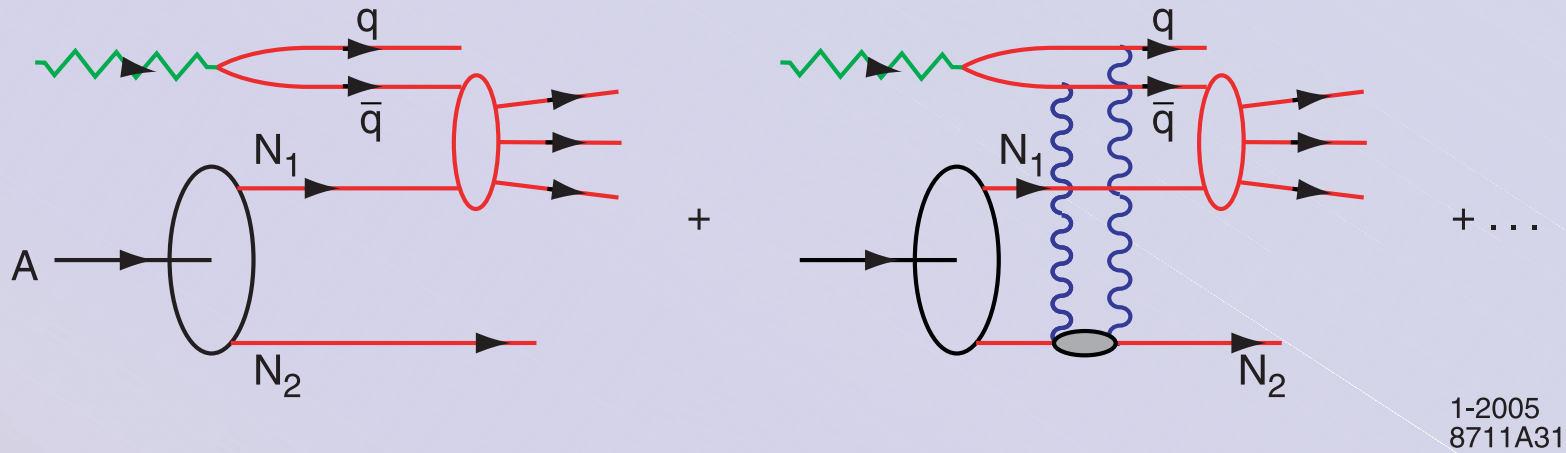

Nuclear Shadowing not included in nuclear LFWF !
Connection to DDIS

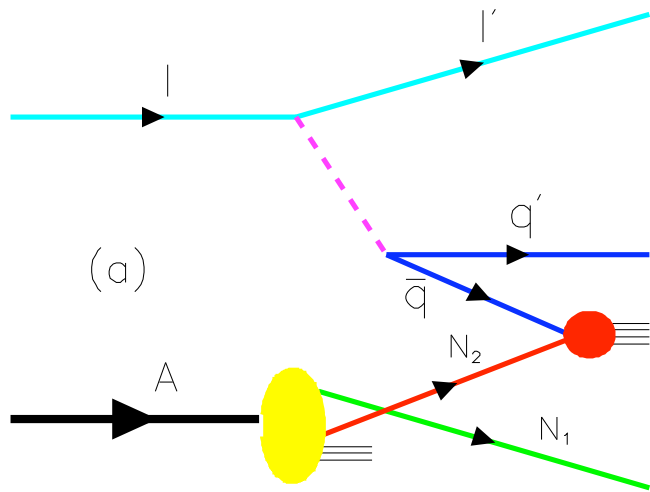

The one-step and two-step processes in DIS on a nucleus.

Coherence at small Bjorken x_B :
 $1/Mx_B = 2\nu/Q^2 \geq L_A$.

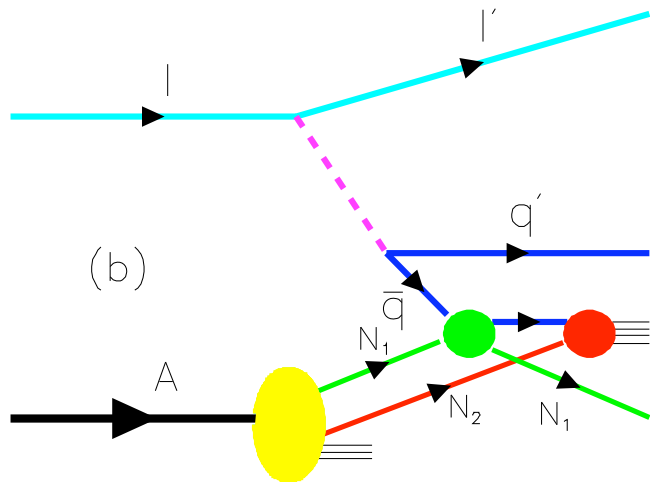

If the scattering on nucleon N_1 is via pomeron exchange, the one-step and two-step amplitudes are opposite in phase, thus diminishing the \bar{q} flux reaching N_2 .

→ Shadowing of the DIS nuclear structure functions.

Kowalski: HERA DDIS produces observed nuclear shadowing

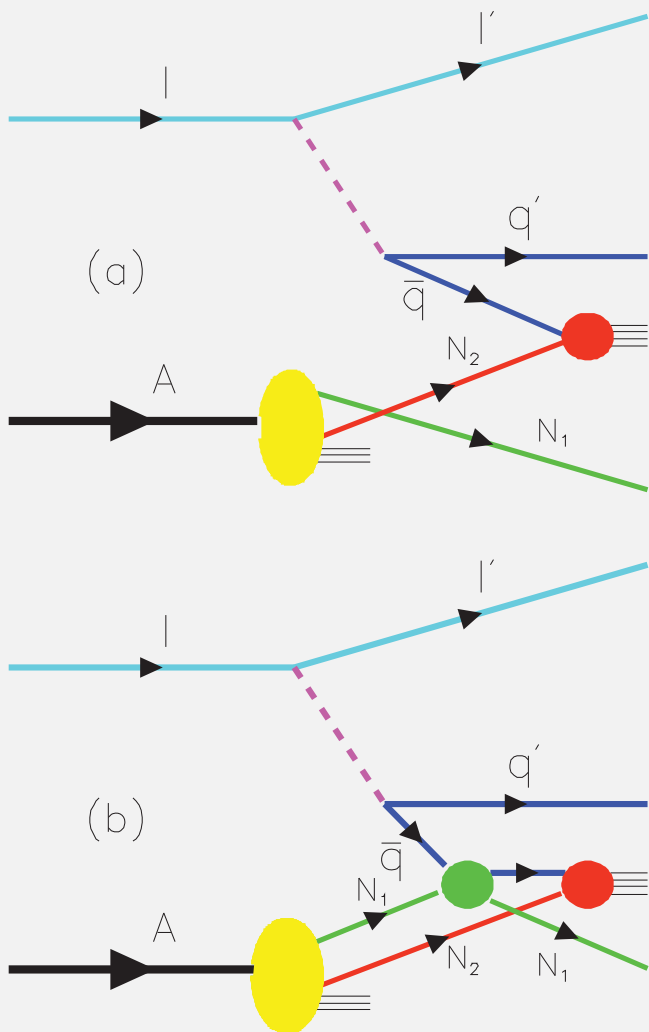

The one-step and two-step processes in DIS on a nucleus.

If the scattering on nucleon N_1 is via $C = -$ Reggeon or Odderon exchange, the one-step and two-step amplitudes are

constructive in phase, enhancing the \bar{q} flux reaching N_2

→ **Antishadowing** of the DIS nuclear structure functions

Reggeon Exchange

Phase of two-step amplitude relative to one step:

$$\frac{1}{\sqrt{2}}(1 - i) \times i = \frac{1}{\sqrt{2}}(i + 1)$$

Constructive Interference

Depends on quark flavor!

Thus antishadowing is not universal

Different for couplings of γ^* , Z^0 , W^\pm

Shadowing and Antishadowing in Lepton-Nucleus Scattering

- Shadowing: **Destructive Interference**
of Two-Step and One-Step Processes
Pomeron Exchange
- Antishadowing: **Constructive Interference**
of Two-Step and One-Step Processes!
Reggeon and Odderon Exchange
- Antishadowing is Not Universal!
Electromagnetic and weak currents:
different nuclear effects !
Potentially significant for NuTeV Anomaly}

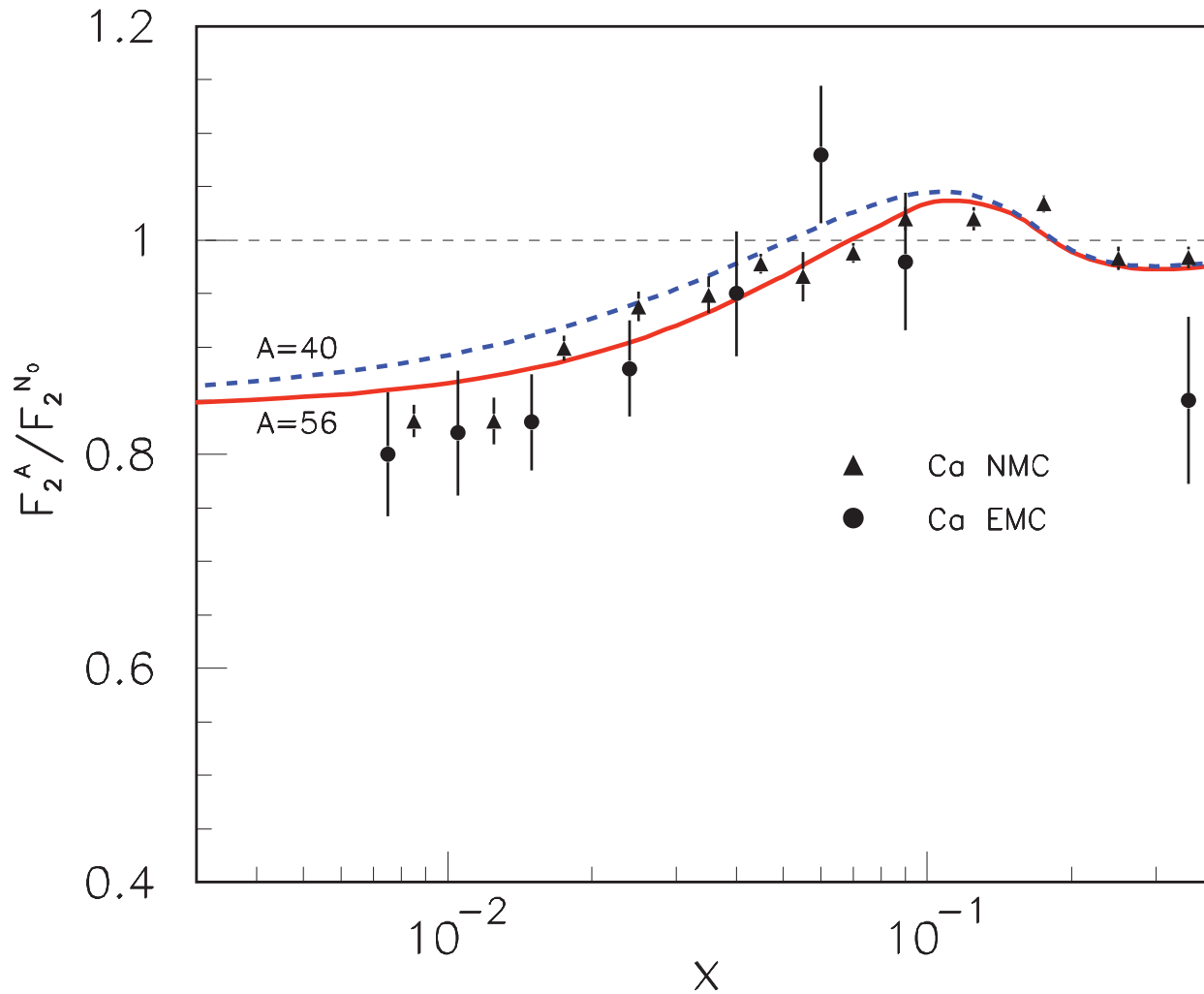

The nuclear shadowing and antishadowing effects at $\langle Q^2 \rangle = 1 \text{ GeV}^2$.

S. J. Brodsky, I. Schmidt and J. J. Yang,
 “Nuclear Antishadowing in
 Neutrino Deep Inelastic Scattering,”
 Phys. Rev. D 70, 116003 (2004)
 [arXiv:hep-ph/0409279].

Shadowing and Antishadowing in Lepton-Nucleus Scattering

- Shadowing and Antishadowing in DIS arise from interference of multi-nucleon processes in nucleus **Phases!**

- Not due to nuclear wavefunction
Wavefunction of stable nucleus is real.
Effect of multi-scattering of $q\bar{q}$ in nucleus.

- Bjorken Scaling :
Interference requires leading-twist diffractive DIS processes

See: Talk by I. Schmidt

Estimate 20% effect on extraction of $\sin^2 \theta_W$
for NuTeV

Need new experimental studies of
antishadowing in

- Parity-violating DIS
- Spin Dependent DIS
- Charged and Neutral Current DIS

Key QCD Experiment at J-PARC

Measure nuclear shadowing, antishadowing at J-PARC in Drell-Yan reactions

$$pA \rightarrow \ell^+ \ell^- X$$

$$Q^2 = x_1 x_2 s \quad x_1 x_2 = .05, x_F = x_1 - x_2$$

$$A^\alpha(x_1) = \frac{2 \frac{d\sigma}{dQ^2 dx_F}(pA \rightarrow \ell^+ \ell^- X)}{A \frac{d\sigma}{dQ^2 dx_F}(pd \rightarrow \ell^+ \ell^- X)}$$

Higher twist effects at high x_F :

Deviations from $(1 + \cos^2 \theta)$

$\cos 2\phi$ correlation.

Physics of Rescattering

- Diffractive DIS: New Insight into Final State Interactions in QCD
- Origin of Hard Pomeron
- Structure Functions not Probability Distributions
- T-odd SSAs, Shadowing, Antishadowing
- Diffractive dijets/ trijets, doubly diffractive Higgs
- Novel Effects: Color Transparency, Color Opacity, Intrinsic Charm, Odderon

Novel Tests of QCD
at J-PARC

Hadron Dynamics at the Amplitude Level

- DIS studies have primarily focussed on probability distributions: integrated and unintegrated
- We need to determine hadron wavefunctions!
- Test QCD at the amplitude level!
- Phases, multi-parton correlations, spin, angular momentum

New Perspectives on QCD from AdS/CFT

- LFWFs: Fundamental description of hadrons at amplitude level
- QCD is Nearly Conformal
- Holographic Model from AdS/CFT : Confinement at large distances and conformal behavior at short distances
- Model for LFWFs, meson and baryon spectra
- Quark-interchange dominates scattering amplitudes

Hard Diffraction from Rescattering

- Diffractive DIS: New Insight into Final State Interactions in QCD
- Origin of Hard Pomeron
- Structure Functions not Probability Distributions
- T-odd Single-Spin Asymmetries
- Diffractive dijets/ trijets
- Color Transparency, Color Opaqueness

Novel Tests of QCD
at J-PARC

Essential to test QCD

- J-PARC
- GSI antiprotons
- 12 GeV Jlab
- BaBar/Belle: ISR, two-gamma, timelike DVCS
- RHIC/LHC Nuclear Collisions; LHCb
- photon-photon collider at the ILC
- electron-proton, electron-nucleus collisions

Novel Tests of QCD
at J-PARC

Novel Tests of QCD at J-PARC

- Color Transparency
- Intrinsic Charm, Octoquarks
- Hidden Color
- Testing Conformal Invariance; Counting Rules IR Fixed Point
- Impact of AdS/CFT
- Single-Spin Effects
- Novel Spin Correlations
- Antishadowing
- Single and Double Diffractive processes

Novel Tests of QCD
at J-PARC