



Series 6000
VME, VME64x, VME64xP VXI

User's Manual

General Remarks

The only purpose of this manual is a description of the product. It must not be interpreted as a declaration of conformity for this product including the product and software.

W-IE-Ne-R revises this product and manual without notice. Differences of the description in manual and product are possible.

W-IE-Ne-R excludes completely any liability for loss of profits, loss of business, loss of use or data, interrupt of business, or for indirect, special incidental, or consequential damages of any kind, even if **W-IE-Ne-R** has been advised of the possibility of such damages arising from any defect or error in this manual or product.

Any use of the product which may influence health of human beings requires the express written permission of **W-IE-Ne-R**.

Products mentioned in this manual are mentioned for identification purposes only. Product names appearing in this manual may or may not be registered trademarks or copyrights of their respective companies.

No part of this product, including the product and the software may be reproduced, transmitted, transcribed, stored in a retrieval system, or translated into any language in any form by any means with the express written permission of **W-IE-Ne-R**.

Mains Voltage

The Power supplies are equipped with a “World”- mains input, which works properly from 94VAC up to 264VAC and within a frequency range of 47 to 63Hz.

Before connecting to the mains please double-check correspondence.

Safety

After connecting the Power box to the mains, the mains input module is powered permanently. Filter and storage capacitors of the power factor correction module are charged with about **400VDC**. The DC-On-Signal as well as a power switch at control board (if any installed) operates as a DC on/off switch only and not as a mains breaker. **Therefore it becomes dangerous if the box cover is open. In this case a lot of components on high voltage potential get touchable!**

Before starting any kind of work inside the power box remove the unit from mains and wait a couple of minutes with your activities! Discharge the primary DC Filter-capacitors by use of a well isolated 22 ohm 10W resistor.

Declaration of Conformity

Art. 10.2 of 89/336 and 89/392 / ECC

W-IE-NE-R
Plein & Baus GmbH

declare under our own responsibility that the product

VME / VXI 6021/23 Crate
Items: 0B0x.xxxx, 0F00.xxxx, 0P00.xxxx C, E

to which this declaration relates, is in conformity with the following standards or normative documents :

1. EN 50 081 - 1
2. EN 61 000 3 - 2
3. EN 50 082 - 1
4. EN 60 950

Conditions:

This crate is not a final product. The use after installation and powered modules inside needs possibly additional screenings to be in conformity of the definition. Admitted for powering by all mains.

Name and signature of authorized person

Place and Date

Name und Unterschrift des Befugten

Ort und Datum

Juergen Baus

Techn. Director

Febr. 2000

Table of contents:

1	General Information	1
1.1	6021 Crates.....	1
1.2	6020 Fan Trays	1
1.2.1	LX Fan Trays.....	1
1.2.2	EC Fan Trays.....	2
1.3	6021 Power Supplies.....	2
2	Operation, Function and Connections.....	2
2.1	Fan Tray Operation and Control.....	2
2.1.1	Function of Fan Tray Switches.....	3
2.1.2	Additional temperature sensors	4
2.1.3	Information by Fan Tray LED's.....	4
2.1.4	Hot Swapping of Fan Tray	4
2.1.5	Programming of Fan tray.....	5
2.1.6	Standard Measurement Ranges	7
2.2	6021-6023 Bin Technical details:.....	8
2.2.1	VME-Bus Terminology, Signal Identification	8
2.2.2	VME (VXI) Bus Current Ratings.....	9
2.2.3	Pin Assignments of J1 and J2 VME Bus.....	11
2.2.4	Pin Assignment Jaux of VME 430-Bus.....	12
2.2.5	Pin Assignments of VME 64x-Bus	14
2.2.6	Special Pin Assignment Jo of VME 64xP (VIPA)-Bus.....	17
2.2.7	Pin Assignments of VXI-Bus	18
2.3	Power Supply UEP6021	22
2.3.1	Power Connector Board	22
2.3.2	Sense and Signal Connector-SUB D 37	23
2.3.3	Fan tray and Control Connector	23
2.3.4	Control and Adjustment of 6021 Power Supply.....	24
2.3.5	Connection of a Personal Computer to the Power Supply UEP6021	26
2.3.6	Output Voltage Adjustments	27
3	CANbus (optional).....	27
	APPENDIX A : Technical Details of 6021 Power Supplies	28
	APPENDIX B : Technical Details of Fan Trays	29
	APPENDIX C : VME 430 Backplane, Situation of Jaux Connector	30

1 General Information

1.1 6021 Crates

The VME/VXI-Crate 6021 consist of a power supply (UEP 6021), bin (UEV 6021 / 6023) and a fan tray (UEL 6020). All these components are plugable and easily to exchange.. Divider sets 6U/9U can be mounted into bins for 9U format modules. For powering of 6021 and 6023 bins same UEP 6021 power supplies have to be used.

Standard crates are available for different module formats: 160, 220, 280, 340, as well as 400mm deep and 6 or 9 units high. 6021 bins are additionally two units and the 6023 bins three units higher (fan tray space). Available W-IE-NE-R VME backplanes: VME64 with J1/J2, VME430 with J1/Jaux/J2, VME64x, VME64xP, VME64xC with Jo special (Cern).

1.2 6020 Fan Trays

The-fan trays are plugged into the bin from the front side. For efficient cooling, controlling and monitoring of the crate various fan trays are constructed according to the slot deepness, whereas both, front and bottom air supply, is possible. Fan rotation speed is shown by use of LX fan trays and can be regulated; every fan is single controlled. Furthermore temperature of the air entry and optionally the exhaust above selected slots.

The UEL 6020 fan tray and control unit occupies two units of a 6021 crate below the VME / VXI-bus slots.

For 6023 crates an additional plenum chamber of 1 unit homogenized the cooling air flow. Fan trays with a depth of 160 and 220mm are equipped with three axial D.C. blowers, while 280, 340 and 400mm deep fan trays have 6 blowers. To cool the rear transition area a 9 fold one is available.

Among the a. m. fan trays high performance super blower with four or six blowers can be used, too. The super blower fan tray is outfitted with a topped plenum and generates a high efficient homogenous cooling air flow through the VME modules.

The 3 fold fan-tray can operate in two different modes. Either the air is taken from the front and then pushed upwards to the modules or from bottom side, which gives full cooling efficiency.

The maximal air flow reached by a 3-fold W-IE-NE-R fan-tray with bottom inlet is greater than 540 m³/h (LX) and shows a good homogeneity. Working with front air inlet only a reduced air flow of about 400 m³/h is available. Due to the lower homogeneity of the air distribution in this mode only the power dissipation of about 800 W can be cooled. The static pressure is equal to 10 mm water column.

The EC fan tray is the economic version and equipped with same blower than the LX version. Therefore both types give the same cooling performance

1.2.1 LX Fan Trays

All DC voltages (up to 8) at backplane level and the corresponding currents among other are shown by the LX monitoring. The threshold-limits (minimum / maximum voltages and currents) can be set manually or piloted by remote control and remain stored even after lack of voltage. In case of global trip off, the fault will be displayed by the diagnostic system.

VME-signals ACFAIL and SYSRESET are generated according to VME-Specs. SYSRESET can also be released manually.

Remote-control by network (CANbus, IEC-Bus or H.S.CAENET) is optionally possible, whereas IEC and H.S. CAENET need the intelligent version of fan trays (LX) the CANbus may operated with all kind of fan trays.

Furthermore, remote control and monitoring of several crates is possible through a PC's compatible program. Change of trip off limits (specially for currents) through menu is possible (Option). Piloting circuits are isolated from VME-potential.

1.2.2 EC Fan Trays

The simplified fan tray, UEL 6020 EC, has no further facilities than DC on / off switch and Power LED which works also as Status indicator.

Optionally outfitted with CANbus connection.

1.3 6021 Power Supplies

The VME power supply of the 6000 series is a micro-processor controlled switching power supply designed in the high density W-IE-Ne-R - cavity technology, which provides a extremely low noise output voltage.

The mains input includes a power factor correction module (PFC) with main filters, soft start- circuit and fuses. For H and K inputs and VHC power supplies an external fuse or circuit breaker has to be installed with a capability of 16A (H) and 32A(K). which works according to EN 60 555-2/IEEE 555-2

The AC- input module is permanently powered after connecting the unit to the AC- mains. POWER ON/OFF activates only the DC on/off function of the power inverter modules. The EN 50 081-1 for generic emissions as well as the EN 50 082-1 or 2 for immunity standards, in particular EN 55 011 RFI rejection (incl. VDE 0871 class B) and EN 55 022 electromagnetic compatibility is accomplished. The insulation performs the EN 60 950, ISO 380, VDE 0805 (SELV)! Furthermore are considered UL 1950, UL 1012, UL 478, C 22.2.950, C 22.2.220/234.

Therefore the UEP 6021 power supplies can fulfil the CE rules comprehensively and will CE marked for use at all power nets.

Turning on the power supply all voltages reach the nominal values nearly simultaneously within $50^{+/-}2.5$ ms (start-end-time) whereby the voltage versus time curve shows a monotonic behavior. The start-off-time which corresponds to a value of 10% of the nominal voltages is reached after $2.5^{+/-}2.5$ ms. The turn-on inrush current is limited by a soft start-circuit to a maximum value of 12 A.

The power packs are readily replaceable. The maximum output power is 700... 2000W with C input and 1400... >3000W with H input, correspondence with 92... 264VAC input voltage. For 6U power packs the output can be increased to the double if two mains input modules work in parallel (E or K suffix).

2 Operation, Function and Connections

2.1 Fan Tray Operation and Control.

All monitoring and control operations are performed by a micro-processor based alarm and control circuit placed inside the UEP 6021 power supply monitored by UEL 6020LX (EC via CANbus only) fan trays. To protect both the power supply and the VME modules, a DC cut-off is started in the case of:

- **overheat:** in the power modules (each module is equipped with temperature sensors);

- **overload:** if maximal current is exceeded (trip-off due to programmed lower values is not indicated as overload)
- **overvoltage:** if voltage >125% (default, crow bar function) and if voltage >105% (default, can be changed via LX fan tray or network)
- **undervoltage:** if voltage <97.5% % (default, can be changed via LX fan tray or network)
- **fan failure:** if one or more fans fail

The reasons of a trip off will be displayed on the alphanumerical LX display.

Voltages, currents, cooling air temperatures (selectable °F - °C), fan speed, power dissipation of inserted modules, operation time of power supply and fan tray and optional net parameters, can be shown on the alphanumeric display of the fan-tray. The ADC resolution is 10 bit. The accuracy of the voltage measurement is better than 0.5%. The total accuracy of the current measurement depends on the corresponding voltage, i.e. for ±5V it is better than 2A in the range between 5A - 50A and for -2V it is better than 1A in the range between 1A - 20A. Above these current ranges the accuracy is <5% of the final value. In the case of ±12V and ±15V the accuracy is better than 0.2 in the whole current range.

2.1.1 Function of Fan Tray Switches

POWER ON /Off	main switch for ventilation and power supply
MODE SELECT	selection switch to choose items and values for fan-tray and power supply monitoring and control
SYS RES	protected located switch for VME SYSRESET circuit activation
FAN SPEED	push button for step wise in- or decrease of fan speed.
FAN AUTO OFF	switch to choose between local and remote warning or D.C. cut-off after fan-failure
ADDRESS	Optional if remote network is installed
LOCAL	Optional if remote network is installed (IEC Bus only)

The adjusting range of fan speed is from 1200 RPM up to >3000 RPM. Pre selected reference speed and displayed value are average RPM. The display shows the fan speed in flashing mode if the selected speed is not equal with the true speed. This happens when either the fans are still accelerated to the higher turns or the selected value is not reachable (if >3000 RPM and higher density of modules inserted in the bin, etc.). After a certain time the FAN FAIL circuit will detect this status as fan fail! While the display shows average speed of all fans only, the CANbus option (or other supported remote interfaces) will transmit the turns of each blower situated inside the fan tray.

2.1.2 Additional temperature sensors

Optionally installed temperature sensor(s), measuring the exhaust air, allows to switch the fan to stop. That will be achieved by keeping pushed the FAN SPEED button to lower speed about 10 seconds.

Also the sensor(s) will

- accelerate the fan speed to the maximum if the first (FanUp) programmed temperature threshold exceeds (default: 45°C) . During the out coming cooling air is above these thresholds, adjustment to lower fan turns is disabled, until the exhaust temperature is below the limits again.
- switch off the power supply if the second (PsOff) programmed temperature threshold exceeds (default: disabled) .

The sensors are placed normally above selected slots at the bin. In combination with EC fan trays these sensors can substitute the function of the LX fan fail circuit, partially.

2.1.3 Information by Fan Tray LED's

AC POWER	green large LED if <i>POWER</i> is on
STATUS	green LED if all voltages are within the limit
FAN FAIL	yellow LED if a fan failure is recognized
OVERHEAT	yellow LED if an overheat in the power supply occurs
SYS FAIL	red LED if VME-bus system generates the <i>SYSFAIL</i> signal (system failure)
FAN SPEED	Red LED if fan speed below 100%
AUTO OFF	red LED indicates DC cut off disabled, remote warning only, hot swapping of fan tray possible now
LOCAL	Optional if remote network is installed

2.1.4 Hot Swapping of LX Fan Tray

When the FAN AUTO OFF circuit is disabled (no trip off in case of any fan failure) the crate may be fully powered during withdrawal of the fan tray. The max. DC- on time has to be programmed (default 10s).

If programmed PsOff- limits of optional installed temperature sensors exceed during fan tray exchange the power supply will trip off to prevent any damage to inserted modules.

2.1.5 Programming of Fan tray

Fan tray parameters (and in the same way many power supply parameters!!) may be changed via the alphanumeric control.

The general procedure is:

- Switch the POWER and the MODE switch up simultaneous for 5 seconds. The display shows „Config: Wait....“ and „Config: Ready !“. Then release both switches.
- If a sub-menu exists, you may now select the sub-menu item (MODE switch up/down). If no sub-menu exists, you may change the parameter value (MODE switch up/down)
- To change a parameter of a sub-menu, select it (POWER switch up). The selected parameter is flashing now.
- You may alter the parameter now (MODE switch up/down)
- After finishing the parameter programming, leave the submenu or configuration menu (POWER switch down).

Programmable parameters of a fan tray:

Mode	associated parameter submenu	Description
Fans	Watching x Fans	Display of the number of monitored fans
Fan Temp	Temp Display: °C Temp Display: °F	Select the temperature unit: Celsius or Fahrenheit
	Hot Swap time	The time after which the power supply will switch off after the fan tray has been removed (disabled, 5...30 seconds, never), must be activated with the AUTO OFF switch)
Bin Temp x (up to 8 sensors)	PsOff	If the temperature of sensor x is above this limit, the power supply will switch off.
	FanUp	If the temperature of sensor x is above this limit, the fan speed will increase to full speed.

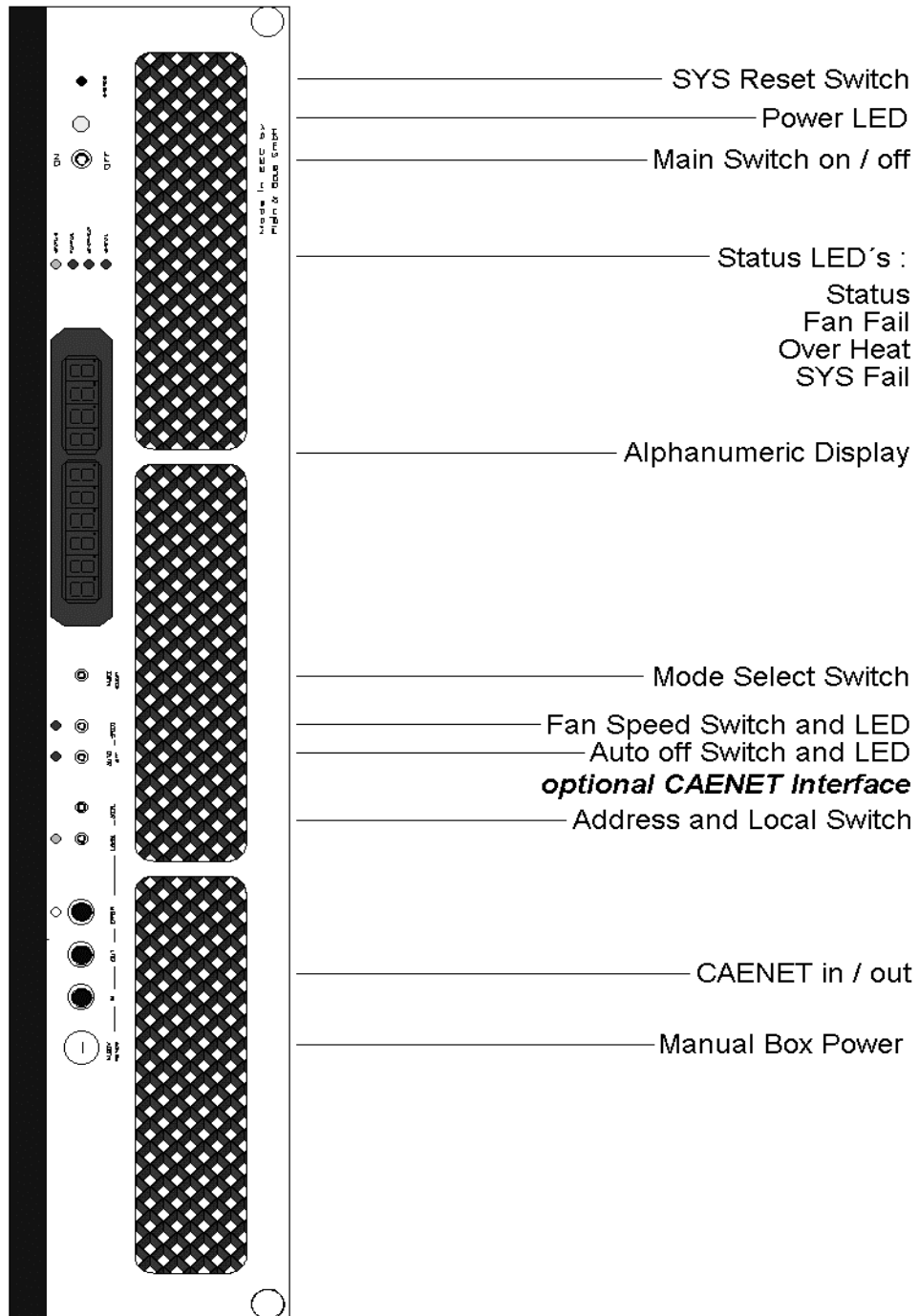

LX 6020 fan-tray front panel with optional CAENET interface

2.1.6 Standard Measurement Ranges

Available Modes and Display Examples (LX Fan trays only)			
Mode	Monitored	Values	Description
+5V	5.00 V	115A.... 230A (460)	+5V channel
+12V	12.0 V	11.5 / 46.0A (92)	+12V channel
+15V) ¹	15.0 V	11.5 / 35.0A (70)	+15V channel
+24V) ¹	24.0 V	11.5 / 23,0 A (66)	+15V channel
+3,3V	3.30 V	115.... 230A (460)	3,3V channel
+48V) ¹	48,0 V	13,5... 67A	
-5V	5.20 V	100A.... 400A	-5.2V channel
-12V	12.0 V	6.0 / 10.0 / 40.0A (80)	-12V channel
-15V) ¹	15.0 V	6.0 / 10.0 / 30.0A (80)	-15V channel
-24V) ¹	24.0 V	6.5 / 20,0A (80)	-24V channel
-2V	2.00 V	100.0A.... 200A	-2V channel
POWER	135	W	output power
FANS	3000	RPM	fan rotation speed
FAN TEMP	25	° C or °F	fan air inlet temp.
FAN TIME	82000,6	h	Operating hours Fan tray
P.S. TIME	150000,0	h	Operating hours Power Supply
Options			
BIN TEMP 1	35°C	° C or °F	bin slot 1 (?) temp.
BIN TEMP 2		° C or °F	bin slot 2 (?) temp.
..... up to			
BIN TEMP 8		° C or °F	bin slot 8 (?) temp.
Networks *			
CAEN*	ADDR	99	CAENET address
BAUD*	RATE	1 MBAUD	CANbus bit rate
CANbus*	ADDR	127	CANbus address
IEC*	ADDR	25	IECbus address

)¹ Either the 15V-, the 24V- or the 48V- output will be in use, depending on the application (VME, VME64x, VXI)

2.2 6021-6023 Bin Technical details:

2.2.1 VME-Bus Terminology, Signal Identification

BR0*-BR3*	Bus request (0-3). Open-collector driven signals generated by requesters. A low level on one of these lines indicates that some master need to use the DTB
D00-D31	Data bus. Three-state driven bi-directional lines used to transfer data between masters an slaves, and status/ID information from interrupters to interrupt handlers.
DS0*, DS1*	Data strobe zero, one. Three-state driven signals used in conjunction with LWORD* and A01 to indicate how many byte locations are being accessed (1, 2, 3, or 4). In addition, during a write cycle, the falling edge of the first data strobe indicates that valid data is available on the data bus. On a read cycle, the rising edge of the first data strobe indicates that data has been accepted from the data bus.
DTACK*	Data transfer acknowledge. An open-collector driven signal generated by a SLAVE. The falling edge of this signal indicates that valid data is available on the data bus during a read cycle, or that data has been accepted from the data bus during a write cycle. The rising edge indicates when the slave has released the data bus at the end of a read cycle.
GND	the dc voltage reference for the system
IACK*	interrupt acknowledge. An open-collector or three-state driven signal used by an interrupt handler to acknowledge an interrupt request. It is routed, by way of a backplane signal trace, to the IACKIN* pin of slot 1, where it is monitored by the IACK daisy-chain driver.
IACKIN*	interrupt acknowledge in. A totem-pole driven signal. The IACKIN* and IACKOUT* signal indicates to the board receiving it that it is allowed to respond to the interrupt acknowledge cycle that is in progress.
IACKOUT*	Interrupt acknowledge out. A totem-pole driven signal. The IACKIN* and IACKOUT* signal is sent by a board to indicate to the next board in the daisy-chain that it is allowed to respond the interrupt acknowledge cycle that is in progress.
IRQ1*-IRQ7*	Interrupt request (1-7). Open-collector driven signals, that are driven low by interrupters to request an interrupt. When several lines are monitored by a single handler the highest numbered line is given the highest priority.
LWORD*	Longword. A three-state driven signal used in conjunction with DS0*, DS1*, and A01 to select which byte location(s) within the 4-byte group are accessed during the data transfer.
RESERVED	Reserved. A signal line reserved for future enhancements.
SERCLK	Serial clock. A totem-pole driven signal that is used to synchronize the data transmission on the VMSbus.

SERDAT*	Serial data. An open collector driven signal that is used for VMSbus data transmission.
SYSCLK	System clock. A totem-pole driven signal that provides a constant 16 MHz clock signal that is independent of any other bus timing.
SYSFAIL*	System reset. An open-collector driven signal that indicates when a failure has occurred in the system. This signal can be generated by any board in the system.
SYSRESET*	System reset. An open-collector driven signal, which when low, causes the system to be reset.
WRITE*	Write. A three-state driven signal generated by the master to indicate whether the data transfer cycle is a read or write. A high level indicates a read operation; a low level indicates a write operation.
+ 5 V STDBY	+ 5V dc standby. This line supplies 5 V dc to devices requiring battery backup.
+ 5 V	+ 5 V dc power. Used by system logic circuits.
+ 12 V	+ 12 V dc power. Used by system logic circuits.
- 12 V	- 12 V dc power. Used by system logic circuits.

2.2.2 VME (VXI) Bus Current Ratings

Power distribution	VME	VME	VME	VME 430	VME 64x
each slot (20°C / 70°C)	J1	J2	J1-J2	J1-Jaux-J2	J1
3,3V					17/12A
5V	9,5/7,5A	9,5/7,5A	19/15A	19/15A	8,5/6A
+/-12V	3,2/2,5A		3,2/2,5A	3,2/2,5A	1,7/1,2A
+/-15V				3,2/2,5A	
-5,2V				19/15A	
-2V				9,5/7,5A	
Vw, Vx, Vy, Vz					
V1, V2					1,7/1,2A
Layers	8	4	8	8	10
Type of ADC	mech		mech	mech	active
Termination on board	passive	passive	passive	passive	active
J2 with 160pin		optional	optional	optional	
Power Connections	Studs	Studs	Studs	Studs	Bugs

Power distribution	VME 64x	VME64xP	VXI C size	VXI D size
each slot (20°C / 70°C)	J1-Jo-J2	J1-Jo-J2 Slot 2- 21) ¹	J1-J2	J1-J2-J3
3,3V	17/12A	17/12A		
5V	15,3/10,8A	27/19A	14/10,5A	24/18A
+/-12V	1,7/1,2A	1,7/1,2A	2/1,5A	4/3A
+/-15V				
-5,2V			10/7,5A	20/15A
-2V			4/3A	10/7,5A
+/-24V			2/1,5A	4/3A
Vw, Vx, Vy, Vz	4/3A	4/3A		
V1, V2	1,7/1,2A	1,7/1,2A		
Layers	10	18	10	10
Type of ADC	active	active	active	active
Termination on board	active	active	active	active
Power Connections	Bugs	Bugs	Studs	Studs

)¹ **On slot 1 of the 64xP backplane the Jo is not feeding additional 5V pins. Therefore the current capability for +5V is only 15,3/10,8A.**

2.2.3 Pin Assignments of J1 and J2 VME Bus

Pin No.	J1			J2		
	Row A	Row B	Row C	Row A	Row B	Row C
01	D00	BBSY*	D08	User defined	+5 V	User defined
02	D01	BCLR	D09	User defined	GND	User defined
03	D02	ACFAIL*	D10	User defined	Reserved	User defined
04	D03	BG0IN*	D11	User defined	A24	User defined
05	D04	BG0OUT*	D12	User defined	A25	User defined
06	D05	BG1IN*	D13	User defined	A26	User defined
07	D06	BG1OUT*	D14	User defined	A27	User defined
08	D07	BG2IN*	D15	User defined	A28	User defined
09	GND	BG2OUT*	GND	User defined	A29	User defined
10	SYSCLK	BG1IN*	SYSFAIL*	User defined	A30	User defined
11	GND	BG3OUT*	BERR*	User defined	A31	User defined
12	DS1*	BR0*	SYSRESET*	User defined	GND	User defined
13	DS0*	BR1*	LWORD*	User defined	+5 V	User defined
14	WRITE*	BR2*	AM5	User defined	D16	User defined
15	GND	BR3*	A23	User defined	D17	User defined
16	DTACK*	AM0	A22	User defined	D18	User defined
17	GND	AM1	A21	User defined	D19	User defined
18	AS*	AM2	A20	User defined	D20	User defined
19	GND	AM3	A19	User defined	D21	User defined
20	IACK*	GND	A18	User defined	D22	User defined
21	IACKIN*	SERCLK	A17	User defined	D23	User defined
22	IAOUT*	SERDAT	A16	User defined	GND	User defined
23	AM4	GND	A15	User defined	D24	User defined
24	A07	IRQ7*	A14	User defined	D25	User defined
25	A06	IRQ6*	A13	User defined	D26	User defined
26	A05	IRQ5*	A12	User defined	D27	User defined
27	A04	IRQ4*	A11	User defined	D28	User defined
28	A03	IRQ3*	A10	User defined	D29	User defined
29	A02	IRQ2*	A09	User defined	D30	User defined
30	A01	IRQ1*	A08	User defined	D31	User defined
31	-12 V	+5V STDBY	+ 12 V	User defined	GND	User defined
32	+5 V	+ 5 V	+ 5 V	User defined	+ 5 V	User defined

2.2.4 Pin Assignment Jaux of VME 430-Bus

Pin Number	Row A	Row B	Row C
01	SN1	GND	SN2
02	SN3	GND	SN4
03	SN5	GND	GND
04	CK*	GND	CK
05	SG*	GND	SG
06	CL*	GND	CL
07	-2 V	-2 V	-2 V
08	- 15 V	CE	+ 15 V
09	- 5,2 V	-5,2 V	- 5,2V
10	- 5,2 V	- 5,2 V	- 5,2V

2.2.4.1 Terminology and Signal Identification of Jaux

SN1... SN5, Binary coded slot No. lines, Geographical address

Slot Number	SN1	SN2	SN3	SN4	SN5
01	NC	GND	GND	GND	GND
02	GND	NC	GND	GND	GND
03	NC	NC	GND	GND	GND
04	GND	GND	NC	GND	GND
05	NC*	GND	NC	GND	GND
06	GND	NC	NC	GND	GND
19	NC	NC	GND	GND	NC
20	GND	GND	NC	GND	NC
21	NC	GND	NC	GND	NC

NC = No Connection (represents H- level, generated by 5k6 resistor on VME modul for TTL, e.g.)

CK, SG and CL signals, Clean Earth

CK, Clock signal, bussed differential line terminated on both sides of the backplane (2 resistors to ground and 1 resistor in between the two lines according to the impedance .

CK positive logic
 CK* negative logic

SG, Start / Stop Gate, bussed differential line terminated like CK lines.

SG positive logic
SG* negative logic

CL, Clear, bussed differential line terminated like CK lines.

CL positive logic
CL* negative logic

CE, Clean Earth , unbussed line without termination.

2.2.5 Pin Assignments of VME 64x-Bus

J1 (extended)

Pin No.	Row Z	Row A	Row B	Row C	Row D
01	MPR	D00	BBSY*	D08	VPC (1)
02	GND	D01	BCLR*	D09	GND (1)
03	MCLK	D02	ACFAIL*	D10	+V1
04	GND	D03	BG0IN*	D11	+V2
05	MSD	D04	BG0OUT*	D12	RsvU
06	GND	D05	BG1IN*	D13	-V1
07	MMD	D06	BG1OUT	D14	-V2
08	GND	D07	BG2IN*	D15	RsvU
09	MCTC	GND	BG2OUT*	GND	GAP*
10	GND	SYSCLK	BG1IN*	SYSFAIL*	GAO*
11	RESP*	GND	BG3OUT*	BERR*	GA1*
12	GND	DS1*	BR0*	SYSRESET*	+3.3V
13	RsvBus	DS0*	BR1*	LWORD	GA2*
14	GND	WRITE*	BR2*	AM5	+3.3V
15	RsvBus	GND	BR3*	A23	GA3*
16	GND	DTACK*	AM0	A22	+3.3V
17	RsvBus	GND	AM1	A21	GA4*
18	GND	AS*	AM2	A20	+3.3V
19	RsvBus	GND	AM3	A19	RsvBus
20	GND	IACK*	GND	A18	+3.3V
21	RsvBus	IACKIN*	SERCLK	A17	RsvBus
22	GND	IAOUT*	SERDAT	A16	3.3V
23	RsvBus	AM4	GND	A15	RsvBus
24	GND	A07	IRQ7*	A14	+3.3V
25	RsvBus	A06	IRQ6*	A13	RsvBus
26	GND	A05	IRQ5*	A12	+3.3V
27	RsvBus	A04	IRQ4*	A11	LI/I*
28	GND	A03	IRQ3*	A10	+3.3V
29	RsvBus	A02	IRQ2*	A09	LI/O*
30	GND	A01	IRQ1*	A08	+3.3V
31	RsvBus	-12 V	+5V STDBY	+12 V	GND (1)
32	GND	+5 V	+5V	+ 5 V	VPC (1)

J2 (extended)

Pin No.	Row Z	Row A	Row B	Row C	Row D
01	User defined	User defined	+5 VAC	User defined	User defined(1)
02	GND	User defined	GND	User defined	User defined(1)
03	User defined	User defined	RESERVED	User defined	User defined
04	GND	User defined	A24	User defined	User defined
05	User defined	User defined	A25	User defined	User defined
06	GND	User defined	A26	User defined	User defined
07	User defined	User defined	A27	User defined	User defined
08	GND	User defined	A28	User defined	User defined
09	User defined	User defined	A29	User defined	User defined
10	GND	User defined	A30	User defined	User defined
11	User defined	User defined	A31	User defined	User defined
12	GND	User defined	GND	User defined	User defined
13	User defined	User defined	+5 V	User defined	User defined
14	GND	User defined	D16	User defined	User defined
15	User defined	User defined	D17	User defined	User defined
16	GND	User defined	D18	User defined	User defined
17	User defined	User defined	D19	User defined	User defined
18	GND	User defined	D20	User defined	User defined
19	User defined	User defined	D21	User defined	User defined
20	GND	User defined	D22	User defined	User defined
21	User defined	User defined	D23	User defined	User defined
22	GND	User defined	GND	User defined	User defined
23	User defined	User defined	D24	User defined	User defined
24	GND	User defined	D25	User defined	User defined
25	User defined	User defined	D26	User defined	User defined
26	GND	User defined	D27	User defined	User defined
27	User defined	User defined	D28	User defined	User defined
28	GND	User defined	D29	User defined	User defined
29	User defined	User defined	D30	User defined	User defined
30	GND	User defined	D31	User defined	User defined
31	User defined	User defined	GND	User defined	GND (1)
32	GND	User defined	+5 V	User defined	VPC (1)

2.2.5.1 Pin Assignment Jo of VME 64x-Bus

J0 (extended)

Pos	Row f	Row e	Row d	Row c	Row b	Row a	Row z
1	GND	User defined	User defined	User defined	User defined	User defined	GND
2	GND	User defined	User defined	User defined	User defined	User defined	GND
3	GND	User defined	User defined	User defined	User defined	User defined	GND
4	GND	User defined	User defined	User defined	User defined	User defined	GND
5	GND	User defined	User defined	User defined	User defined	User defined	GND
6	GND	User defined	User defined	User defined	User defined	User defined	GND
7	GND	User defined	User defined	User defined	User defined	User defined	GND
8	GND	User defined	User defined	User defined	User defined	User defined	GND
9	GND	User defined	User defined	User defined	User defined	User defined	GND
10	GND	User defined	User defined	User defined	User defined	User defined	GND
11	GND	User defined	User defined	User defined	User defined	User defined	GND
12	GND	User defined	User defined	User defined	User defined	User defined	GND
13	GND	User defined	User defined	User defined	User defined	User defined	GND
14	GND	User defined	User defined	User defined	User defined	User defined	GND
15	GND	User defined	User defined	User defined	User defined	User defined	GND
16	GND	User defined	User defined	User defined	User defined	User defined	GND
17	GND	User defined	User defined	User defined	User defined	User defined	GND
18	GND	User defined	User defined	User defined	User defined	User defined	GND
19	GND	User defined	User defined	User defined	User defined	User defined	GND

2.2.6 Special Pin Assignment Jo of VME 64xP (VIPA)-Bus

Some user defined pins of the 64x- Jo connector have been specified in the 64xP (VIPA) document to get available additional voltages and signals on the backplane. The slot 1 pin out is identical to those of the Jo of the 64x pin assignment. Slot 1 to 21 are outfitted with the following pin out:

Jo Slot 2-21

Pin No.	Row z	Row a	Row b	Row c	Row d	Row e	Row f
01	COM	+5V	+5V	+5V	+5V	+5V	COM
02	COM	RET_WX	Reserved	+5V	TBUS1+	TBUS1-	COM
03	COM	RET_WX	Reserved	Reserved	TBUS2+	TBUS2-	COM
04	COM	Vw	Reserved	USER I/O	USER I/O	USER I/O	COM
05	COM	Vw	Reserved	USER I/O	USER I/O	USER I/O	COM
06	COM	RET_WX	Reserved	USER I/O	USER I/O	USER I/O	COM
07	COM	AREF_WX	Reserved	USER I/O	USER I/O	USER I/O	COM
08	COM	RET_WX	Reserved	USER I/O	USER I/O	USER I/O	COM
09	COM	Vx	Reserved	USER I/O	USER I/O	USER I/O	COM
10	COM	Vx	Reserved	USER I/O	USER I/O	USER I/O	COM
11	COM	Vy	Reserved	USER I/O	USER I/O	USER I/O	COM
12	COM	Vy	Reserved	USER I/O	USER I/O	USER I/O	COM
13	COM	RET_YZ	Reserved	USER I/O	USER I/O	USER I/O	COM
14	COM	AREF_YZ	Reserved	USER I/O	USER I/O	USER I/O	COM
15	COM	RET_YZ	Reserved	USER I/O	USER I/O	USER I/O	COM
16	COM	Vz	Reserved	USER I/O	USER I/O	USER I/O	COM
17	COM	Vz	Reserved	Reserved	TBUS3+	TBUS3-	COM
18	COM	RET_YZ	Reserved	Reserved	TBUS4+	TBUS4-	COM
19	COM	RET_YZ	Reserved	Reserved	TBUS_OC1	TBUS_OC2	COM

2.2.7 Pin Assignments of VXI-Bus

VXIbus J1/J2 Connector, Slot 1-13, C- and D- size

Pin No.	J1			J2		
	Row A	Row B	Row C	Row A	Row B	Row C
01	D00	BBSY*	D08	ECLTRG0	+ 5 V	CLK10+
02	D01	BCLR	D09	- 2V	GND	CLK10-
03	D02	ACFAIL*	D10	ECLTRG1	RSV1	GND
04	D03	BG0IN*	D11	GND	A24	-5.2V
05	D04	BG0OUT*	D12	LBUSA00	A25	LBUSC00
06	D05	BG1IN*	D13	LBUSA01	A26	LBUSC01
07	D06	BG1OUT*	D14	-5.2V	A27	GND
08	D07	BG2IN*	D15	LBUSA02	A28	LBUSC02
09	GND	BG2OUT*	GND	LBUSA03	A29	LBUSC03
10	SYSCLK	BG1IN*	SYSFAIL*	GND	A30	GND
11	GND	BG3OUT*	BERR*	LBUSA04	A31	LBUSC04
12	DS1*	BR0*	SYSRESET*	LBUSA05	GND	LBUSC05
13	DS0*	BR1*	LWORD*	-5.2V	+ 5V	-2V
14	WRITE*	BR2*	AM5	LBUSA06	D16	LBUSC06
15	GND	BR3*	A23	LBUSA07	D17	LBUSC07
16	DTACK*	AM0	A22	GND	D18	GND
17	GND	AM1	A21	LBUSA08	D19	LBUSC08
18	AS*	AM2	A20	LBUSA09	D20	LBUSC09
19	GND	AM3	A19	-5.2V	D21	-5.2V
20	IACK*	GND	A18	LBUSA10	D22	LBUSC10
21	IACKIN*	SERCLK	A17	LBUSA11	D23	LBUSC11
22	IAOUT*	SERDAT	A16	GND	GND	GND
23	AM4	GND	A15	TTLTRG0*	D24	TTLTRG1*
24	A07	IRQ7*	A14	TTLTRG2*	D25	TTLTRG3*
25	A06	IRQ6*	A13	+5V	D26	GND
26	A05	IRQ5*	A12	TTLTRG4*	D27	TTLTRG5*
27	A04	IRQ4*	A11	TTLTRG6*	D28	TTLTRG7*
28	A03	IRQ3*	A10	GND	D29	GND
29	A02	IRQ2*	A09	RSV2	D30	RSV3
30	A01	IRQ1*	A08	MODID	D31	GND
31	-12 V	5V STDBY	+ 12 V	GND	GND	+24V
32	+5 V	+ 5 V	+ 5 V	SUMBUS	+ 5V	-24V

VXIbus J2 Connector, Slot 1, C- and D- size

Pin Number	Row A	Row B	Row C
01	ECLTRG0	+ 5 VDC	CLK10+
02	- 2V	GND	CLK10-
03	ECLTRG1	RSV1	GND
04	GND	A24	-5.2V
05	MODID12	A25	LBUSC00
06	MODID11	A26	LBUSC01
07	-5.2V	A27	GND
08	MODID10	A28	LBUSC02
09	MODID09	A29	LBUSC03
10	GND	A30	GND
11	MODID08	A31	LBUSC04
12	MODID07	GND	LBUSC05
13	-5.2V	+ VDC	-2V
14	MODID06	D16	LBUSC06
15	MODID05	D17	LBUSC07
16	GND	D18	GND
17	MODID04	D19	LBUSC08
18	MODID03	D20	LBUSC09
19	-5.2V	D21	-5.2V
20	MODID02	D22	LBUSC10
21	MODID01	D23	LBUSC11
22	GND	GND	GND
23	TTLTRG0*	D24	TTLTRG1*
24	TTLTRG2*	D25	TTLTRG3*
25	+5V	D26	GND
26	TTLTRG4*	D27	TTLTRG5*
27	TTLTRG6*	D28	TTLTRG7*
28	GND	D29	GND
29	RSV2	D30	RSV3
30	MODID	D31	GND
31	GND	GND	+24V
32	SUMBUS	+ 5VDC	-24V

VXIbus J3 Connector, Slot 2-13, **D-** size only

Pin Number	Row A	Row B	Row C
01	ECLTRG2	+24V	+12V
02	GND	-24V	-12V
03	ECLTRG3	GND	RSV4
04	-2V	RSV5	+5V
05	ECLTRG4	-5.2V	RSV6
06	GND	RSV7	GND
07	ECLTRG5	+5V	-5.2V
08	-2V	GND	GND
09	LBUSA12	+5V	LBUSC12
10	LBUSA13	LBUSC15	LBUSC13
11	LBUSA14	LBUSA15	LBUSC14
12	LBUSA16	GND	LBUSC16
13	LBUSA17	LBUSC19	LBUSC17
14	LBUSA18	LBUSA19	LBUSC18
15	LBUSA20	+5V	LBUSC20
16	LBUSA21	LBUSC23	LBUSC21
17	LBUSA22	LBUSA23	LBUSC22
18	LBUSA24	-2V	LBUSC24
19	LBUSA25	LBUSC27	LBUSC25
20	LBUSA26	LBUSA27	LBUSC26
21	LBUSA28	GND	LBUSC28
22	LBUSA29	LBUSC31	LBUSC29
23	LBUSA30	LBUSA31	LBUSC30
24	LBUSA32	+5V	LBUSC32
25	LBUSA33	LBUSC35	LBUSC33
26	LBUSA34	LBUSA35	LBUSC34
27	GND	GND	GND
28	STARX+	-5.2V	STARY+
29	STARX-	GND	STARY-
30	GND	-5.2V	-5.2V
31	CLK100+	-2V	SYNC100+
32	CLK100-	GND	SYNC100-

VXIbus J3 Connector, Slot 1, **D-** size only

Pin Number	Row A	Row B	Row C
01	ECLTRG2	+24V	+12V
02	GND	-24V	-12V
03	ECLTRG3	GND	RSV4
04	-2V	RSV5	+5V
05	ECLTRG4	-5.2V	RSV6
06	GND	RSV7	GND
07	ECLTRG5	+5V	-5.2V
08	-2V	GND	GND
09	STARY12+	+5V	STARX01+
10	STARY12-	STARY01-	STARX01-
11	STARX12+	StARX12-	STARY01+
12	STARY11+	GND	STARX02+
13	STARY11-	STARY02-	STARX02-
14	STARX11+	STARX11-	STARY02+
15	STARY10+	+5V	STARX03+
16	STARY10-	STARY03-	STARX03-
17	STARX10+	STARX10-	STARY03+
18	STARY09+	-2V	STARX04+
19	STARY09-	STARY04-	STARX04-
20	STARX09+	STARX09-	STARY04+
21	STARY08+	GND	STARX05+
22	STARY08-	STARY05-	STARX05-
23	STARX08+	STARX08-	STARY05+
24	STARY07+	+5V	STARX06+
25	STARY07-	STARY06-	STARX06-
26	STARX07+	STARY07-	STARY06+
27	GND	GND	GND
28	STARX+	-5.2V	STARY+
29	STARX-	GND	STARY-
30	GND	-5.2V	-5.2V
31	CLK100+	-2V	SYNC100+
32	CLK100-	GND	SYNC100-

2.3 Power Supply UEP6021

2.3.1 Power Connector Board

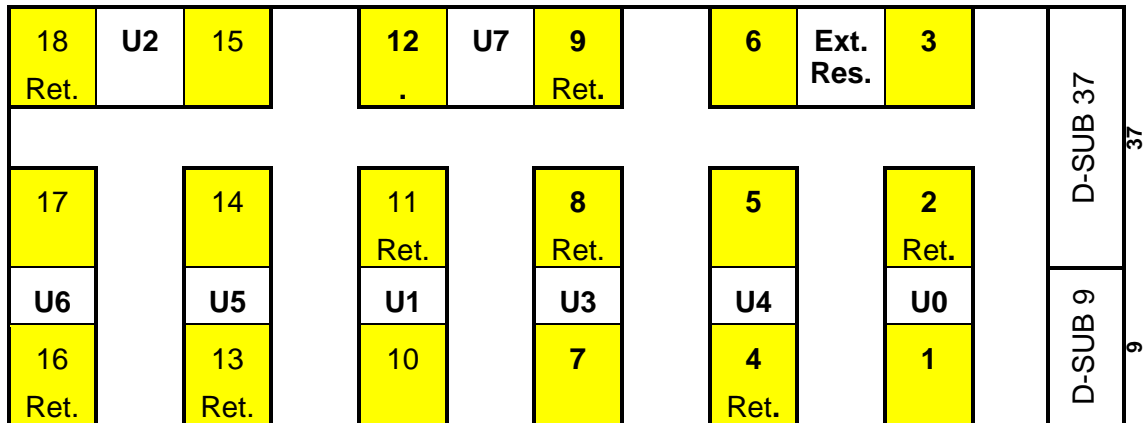

Pin 10,11,13...18: 6mm, 120A max.

Pin 1...9+12: 8mm, 240A max

Ret. Return from common ground rail at backplane

Voltages and Pin outs in Standard VME application

U0	5V (2... 7V) \leq 230A	U1	+12V (7... 24V) < 92A
U2	+15V (7... 24V) < 92A	U3	3,3V (2... 7V) \leq 230A
U4	-5,2V (2... 7V) \leq 230A	U5	-12V (7... 24V) < 92A
U6	-15V (7... 24V) < 92A	U7	-2V (2... 7V) < 115A

Voltages and Pin outs in Standard VME64x application

U0	5V (2... 7V) \leq 230A	U1	+12V (7... 24V) < 92A
U2	+48V (30... 60V) < 92A	U3	3,3V (2... 7V) \leq 230A
U4		U5	-12V (7... 24V) < 92A
U6	-15V (7... 24V) < 92A	U7	

Voltages and Pin outs in Standard VXI application

U0	5V (2... 7V) \leq 230A	U1	+12V (7... 24V) < 92A
U2	+24V (12... 30V) < 92A	U3	
U4	-5,2V (2... 7V) \leq 230A	U5	-12V (7... 24V) < 92A
U6	-24V (12... 30V) < 92A	U7	-2V (2... 7V) < 115A

2.3.2 Sense and Signal Connector-SUB D 37

		19	TEMP RETURN
37	TEMP 0	18	TEMP 1
36	TEMP 2	17	TEMP 3
35	TEMP 4	16	TEMP 5
34	TEMP 6	15	TEMP 7
33	BIN EEPROM: IIC SDA	14	BIN EEPROM: IIC SCL
32	BIN EEPROM:+5V	13	VME LOGIC: SYSRESET
31	BIN EEPROM: GND	12	VME LOGIC: ACFAIL
30	VME LOGIC GND	11	VME LOGIC: SYSFAIL
29	U0 SENSE -	10	U0 SENSE + (VME: +5V)
28	VW SENSE (reserved)	9	VW SENSE (reserved)
27	VX SENSE (reserved)	8	VX SENSE (reserved)
26	U4 SENSE +	7	U4 SENSE -
25	U7 SENSE +	6	U7 SENSE -
24	U2 SENSE -	5	U2 SENSE + (VME: 48V)
23	U6 SENSE +	4	U6 SENSE -
22	U1 SENSE -	3	U1 SENSE + (VME: +12V)
21	U5 SENSE +	2	U5 SENSE - (VME: -12V)
20	U3 SENSE -	1	U3 SENSE + (VME: +3.3V)

2.3.3 Fan tray and Control Connector

		5	CAN_H
9	CAN_L	4	CAN GND
8	RXD	3	TXD
7	+15V (for fan only)	2	+15V (for fan only)
6	-15V (for fan only)	1	-15V (for fan only)

The CANbus Logic is an option. Data exchange between fan tray and power supply has been done by use of serial connection via RXD and TXD.

2.3.4 Control and Adjustment of 6021 Power Supply

2.3.4.1 Control of the Power Supply 6021 via CAN-Bus (optional)

The CAN Bus Signals are provided on the 9 Pin DSUB:

CAN_H:	Pin 5
CAN_L:	Pin 9
CAN_GND:	Pin 4

The software protocol is described in a separate document (Part No *00183)

CANbus is an independent port. It may used to operate the power supply separately or in combination with the fan tray inside the bin

2.3.4.2 Control of the Power Supply 6021 without PC or Control panel (display)

There is a on/off input and a status output function wich are used in combination with an EC- fan tray :

Remote On: 9 Pin DSUB: Close a "make" contact or switch between Pin 8 (Serial Data In, RXD) and Pin 2 or 7.

Status Output: 9 Pin DSUB: Connect a LED between Pin 3 (Serial Data Out, TXD) and Pin 1 or 6.

2.3.4.3 Control of the Power Supply 6021 via Fan tray

Many power supply parameters may be changed via the alphanumeric control of the connected fan tray.

The general procedure is:

- Switch the POWER and the MODE switch up simultaneous for 5 seconds. The display shows „Config: Wait...“ and „Config: Ready !“. Then release both switches.
- If a sub-menu exists, you may now select the sub-menu item (MODE switch up/down). If no sub-menu exists, you may change the parameter value (MODE switch up/down)
- To change a parameter of a sub-menu, select it (POWER switch up). The selected parameter is flashing now.
- You may alter the parameter now (MODE switch up/down)
- After finishing the parameter programming, leave the submenu or configuration menu (POWER switch down).

Table 1 List of manual Programming Features

Mode	associated parameter submenu	Description
Any Voltage (e.g. +5V or U0)	Ilim	Output Current limit
	Uadj	Output voltage fine adjustment. The same function as the switches in the power supply
	Unom	Output voltage coarse adjustment.
	Imax	Monitoring: Maximum current for good status.
	Umin	Monitoring: Minimum voltage for good status.
	Umax:	Monitoring: Maximum voltage for good status.
Power	Auto Power On No Auto Power On	Automatic switch on of the power supply after come back of the mains
	Switch Off Normal Switch Off Delay	Delayed switch off: You have to push the POWER switch down for 5 seconds until the power supply switches off

2.3.5 Connection of a Personal Computer to the Power Supply UEP6021

The needed staff is an PC running Windows, the control program UEP6 and a simple adapter ("Dongle"). For more details, view the document *00461.A0.

X3, 9 Pin DSUB
male (UEP6)

9 Pin DSUB female
(PC)

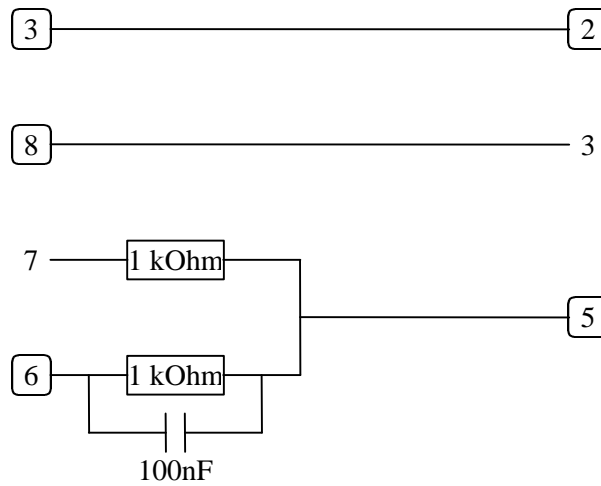

2.3.6 Output Voltage Adjustments

All output voltages can be adjusted manually via the two rotary switches situated on the power supply top.

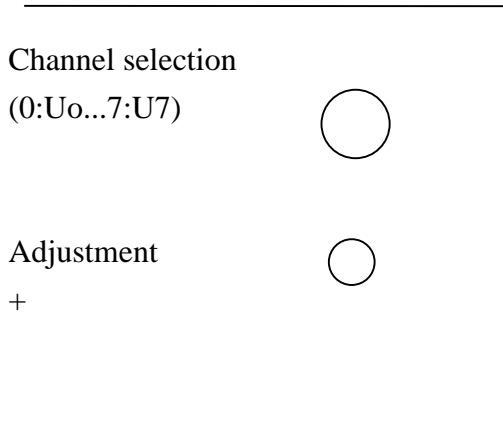

Mode Selection	Function
0-7	Adjust Voltage of U0-U7
A	CAN Address (low, Bit 0-3)
B	CAN Address (high, Bit 4-6)
C	CAN General Call Address (low, Bit 0-3)
D	CAN General Call Address (high, Bit 4-6)
E	CAN Transmission Speed Index

3 CANbus (optional)

CAN Transmission Speed Index

Index	Max. Distance	Bit Rate	Type
0	10 m	1.6 Mbit/s	high- speed (needs termination)
1	40 m	1.0 Mbit/s	
2	130 m	500 kbit/s	
3	270 m	250 kbit/s	
4	530 m	125 kbit/s	
5	620 m	100 kbit/s	low-speed
6	1.300m	50 kbit/s	
7	3.300 m	20 kbit/s	
8	6.700 m	10 kbit/s	
9	10.000 m	5 kbit/s	

For software protocol see separate manual No. *00183

APPENDIX A: Technical Details of 6021 Power Supplies
Mains input

C/E Sinusoidal: **CE** EN 60555, IEC 555 pow. fact. 0,98 (230VAC),
92...264VAC, 10/20A

H/K Sinusoidal: **CE** EN 60555, IEC 555 pow. fact. 0,98 (230VAC),
92...264VAC, 15/30A

Inrush current: limited to nominal input current, max.

Isolation Inp.- outp. **CE** EN 60950, ISO 380, VDE 0805, UL 1950, C22.2.950

Output, power with different mains inputs, DC- voltages

C 700... 2100W, **E** 1400... 4000W, **H** 1000... 3000W, **K** 2100... 6000W

Available modules		min. to max. range	max. output	(with C, E, H, K mains input)
Type	MEH	2... 7,0V	115A / 550W	
Type	MEH	7... 16V	46A / 550W	
Type	MEH	12... 30V	23A / 550W	
Type	MEH	30... 60V	13,5A / 650W	
Type	MDH	2... 7,0V	(+/-) 20A / 140W (280W)	
Type	MDL	7... 24V	(+/-) 11,5A / 140W.(280W)	
Type	MDL	7... 30V	(+/-) 7,4A / 180W.(360W)	

3U box with alternative C or H input, 6U box suitable for all inputs., above 16A AC input terminals with 2m power cord, fixed . Available output power depends on input voltage

Regulation

static: MEH 550W/650W <25mV (+/-100% load, +/- full mains range)
 MDH (20A): <0,1% (+/-100% load, +/- full mains range)
 MDL (11,5A/7,4A): <0,1% (+/-100% load, +/- full mains range)

dyn.: MEH, MDH <100mV (+/-25% load)
 MDL (11,5A/7,4A): <0,7% (+/-25% load)

Recovery time +/-25% load: within +-1% within +-0,1%
 Modules 550W 0,2ms 0,5ms,
 Modules 650W 0,5ms 1,0ms
 MDL (11,5A/7,4A): 0,0ms 1,0ms

Sense compens. range: difference between min. and max. output voltage

Noise and ripple: <10mVpp, (0-20MHz) <3mVrms (0-2MHz)

EMI

RFI-rejection(emission): **CE** EN 50081-1 VDE 0871B

EMC (immunity): **CE** EN 50082-1 or 2

Operation temperature: 0...50°C without derating, Storage:-30°C ... +85°C

Temp.-coefficient: < 0,2% / 10K

Stability (conditions const.): 10mV or 0,1% / 24 hours, 25mV or 0,3% / 6 month

Current limits: adjustable to any lower level

Voltage rise characteristics: monotonic 50ms, processor controlled.

Overvoltage crow bar protection: trip off adjusted to 125% of nominal voltage each output
 DC Off (trip off): within 5ms if >2% deviation from adjusted nominal values,
 after overload, overheat, overvoltage, undervoltage (bad status) and fan fail
 if temperatures exceed 110°C heat sink, 70°C ambient

Trip off points adjustable, processor controlled. Output capacitors will be discharged by the crow bars

Efficiency: 75% ... 85%, depends on used modules
 M T B F: 40°C ambient >65 000 h 25°C ambient >100 000 h

APPENDIX B: Technical Details of Fan Trays

Fan Tray Type	Facilities	No. of Blowers	Depth	Max. Air Flow
6020LX/3	Intelligent	3 x DC	160 mm	>540m ³ / h
6020 EC/3	Simplified	3 x DC	160 mm	>540m ³ / h
6020LX/6	Intelligent	6 x DC	370 mm ¹⁾	>1000m ³ / h
6020 EC/6	Simplified	6 x DC	370 mm ¹⁾	>1000m ³ / h
6020LX/4s	Intelligent	4 x DC-Super	400 mm ²⁾	>1500m ³ / h
6020 EC/4s	Simplified	4 x DC-Super	400 mm ²⁾	>1500m ³ / h
6020 LX/6s	Intelligent	6 x DC-Super	600 mm ²⁾	>2200m ³ / h
6020 EC/6s	Simplified	6 x DC-Super	600 mm ²⁾	>2200m ³ / h
6020 LX/9	Intelligent	9 x DC	600 mm ²⁾	>1600m ³ / h
6020 EC/9	Simplified	6 x DC	600 mm ²⁾	>1600m ³ / h

- 1) changed to 400mm, compatible to 4-fold Super Blower fan tray dimension
- 2) all 400mm and 600mm fan trays for bottom air inlet only. Equipped with topped plenum chamber, 25mm high.

Static pressure: DC blower 10 mm H₂O column
 DC Super blower 15 mm H₂O column

Operating Temperature: 0... 70°C

MTBF: >65 000 h at 40°C ambient, > 85 000 h at 25°C ambient

APPENDIX C: VME 430 Backplane, Situation of Jaux Connector

