

General Standards Corporation
High Performance Bus Interface Solutions

Rev: 092807

PMC66-16AI64SSA/C

**64-CHANNEL 16-BIT SIMULTANEOUS SAMPLING
PMC ANALOG INPUT BOARD**

***With 200KSPS Sample Rate per Channel
and 66MHz PCI Support
and Triggered Bursts***

REFERENCE MANUAL

PMC66-16Al64SSA/C

TABLE OF CONTENTS

<u>SECTION</u>	<u>TITLE</u>	<u>PAGE</u>
1.0	INTRODUCTION	1-1
1.1	General Description	1-1
1.2	Functional Overview	1-2
2.0	INSTALLATION AND MAINTENANCE	2-1
2.1	Board Configuration	2-1
2.2	Installation	2-1
2.2.1	Physical Installation	2-1
2.2.2	Input/Output Cable Connections	2-1
2.3	System Configuration	2-3
2.3.1	Analog Inputs	2-3
2.3.2	External Sync I/O	2-4
2.3.3	Multiboard Synchronization	2-5
2.4	Maintenance	2-5
2.5	Reference Verification	2-5
2.5.1	Equipment Required	2-6
2.5.2	Verification and Adjustment	2-6
3.0	CONTROL SOFTWARE	3-1
3.1	Introduction	3-1
3.2	Board Control Register (BCR)	3-1
3.3	Configuration and Initialization	3-2
3.3.1	Board Configuration	3-2
3.3.2	Initialization	3-3
3.4	Analog Input Parameters	3-3
3.4.1	Input Voltage Range	3-3
3.4.2	Timing Organization	3-3
3.4.3	Scan and Sync Control Register	3-4
3.4.4	Sample Rate Generators	3-4
3.4.4.1	Sample Rate Control	3-4
3.4.4.2	Generator Cascading	3-6
3.4.5	Multiboard Synchronization	3-6
3.5	Analog Input Control	3-6
3.5.1	Input Data Organization	3-6
3.5.1.1	Input Data Buffer	3-6
3.5.1.2	Data Coding Format	3-7

TABLE OF CONTENTS (Continued)

<u>SECTION</u>	<u>TITLE</u>	<u>PAGE</u>
3.5	Analog Input Control (Continued)	3-6
3.5.2	Input Data Buffer Control	3-7
3.5.3	Analog Input Function Modes	3-8
3.5.3.1	System Analog Inputs	3-8
3.5.3.2	Selftest Modes	3-9
3.5.4	Sampling Modes	3-9
3.5.5	Differential Processing	3-9
3.5.5.1	Default Single-Ended Processing	3-9
3.5.5.2	Pseudo-Differential Mode	3-10
3.5.5.3	Full Differential Mode	3-10
3.5.5.4	Differential Scaling Considerations	3-10
3.6	Autocalibration	3-10
3.7	Interrupt Control	3-11
3.7.1	Local Interrupt Request	3-11
3.7.2	Enabling the PCI Interrupt	3-11
3.8	DMA Operation	3-12
3.8.1	Block Mode	3-12
3.8.2	Demand Mode	3-13
3.8.2.1	Autonomous	3-13
3.8.2.2	Threshold-Flag Driven	3-13
3.9	Auxiliary External Sync I/O	3-13
3.10	Board Configuration Register	3-15
3.11	Data Packing	3-15
3.12	Triggered Bursts	3-16
3.12.1	Burst Size and Trigger Source	3-16
3.12.2	Sample Clock Source	3-17
3.13	Active Channel Group Assignment	3-17
4.0	PRINCIPLES OF OPERATION	4-1
4.1	General Description	4-1
4.2	Analog Inputs	4-2
4.3	Rate Generators	4-2
4.4	Data Buffer	4-2
4.5	Autocalibration	4-2
4.6	Power Control	4-2
App A	Local Control Register Quick Reference	A-1
App B	Migration from PMC-16AI64SS	B-1

LIST OF ILLUSTRATIONS

FIGURE	TITLE	PAGE
1.1-1	Physical Configuration	1-1
1.2-1	Functional Organization	1-2
2.2-1	Input/Output Connector	2-3
2.3-1	Analog Input Configurations	2-4
2.3-2	Multiboard Synchronization	2-5
2.5-1	Reference Adjustment Access	2-6
3.4-1	Clock and Sync Organization	3-4
3.9-1	Auxiliary Sync Header	3-14
4.1-1	Functional Block Diagram	4-1

LIST OF TABLES

TABLE	TITLE	PAGE
2.2-1	System Connector Pin Functions	2-2
2.5-1	Reference Verification Equipment	2-6
3.1-1	Control and Data Registers	3-1
3.2-1	Board Control Register (BCR)	3-2
3.3-1	Configuration Operations	3-2
3.4-1	Analog Voltage Range Selection	3-3
3.4-2	Scan and Sync Control Register	3-5
3.4-3	Rate Generator Register	3-5
3.4-4	Rate Generator Frequency Selection	3-5
3.5-1	Input Data Buffer; Nonpacked Data	3-7
3.5-2	Input Data Coding; 16-Bit Data	3-7
3.5-3	Input Data Buffer Control Register	3-8
3.5-4	Buffer Size Register	3-8
3.5-5	Analog Input Function Selection	3-8
3.5-6	Differential Processing Modes	3-9
3.7-1	Interrupt Control Register	3-12
3.8-1	Typical DMA Registers; Block Mode	3-12
3.8-2	Typical DMA Registers; Demand Mode	3-13
3.9-1	Auxiliary Sync I/O Connections	3-14
3.9-2	Auxiliary Sync I/O Control	3-14
3.10-1	Board Configuration Register	3-15
3.11-1	Data Packing	3-15
3.12-1	Burst Trigger Source	3-16
3.13-1	Active Channel Assignment	3-17

SECTION 1.0 INTRODUCTION

1.1 General Description

The PMC66-16AI64SSA/C board is a single-width PCI mezzanine card (PMC) that provides high-speed simultaneous 16-bit analog input capability for PMC applications. 64 analog input lines can be digitized simultaneously at rates up to 200,000 conversions per second per channel, with software-controlled voltage ranges of $\pm 2.5V$, $\pm 5V$, $\pm 10V$, 0 to +5V or 0 to +10V.. The board is functionally compatible with the IEEE PCI local bus specification Revision 2.3, and is mechanically and electrically compatible with the IEEE compact mezzanine card (CMC) specification IEEE 1386. A PCI interface adapter supports the "plug-n-play" initialization concept.

Autocalibration determines offset and gain correction values for each input channel, and the corrections are applied subsequently during acquisition. A selftest switching network routes calibration reference signals to each channel through internal selftest switches, and permits board integrity to be verified by the host.

Power requirements consist of +5 VDC from the PCI bus in compliance with the PCI specification, and operation over the specified temperature range is achieved with conventional air cooling. Specific details of physical characteristics and power requirements are contained in the PMC66-16AI64SSA/C product specification. Figure 1.1-1 shows the physical configuration of the board, and the arrangement of major components.

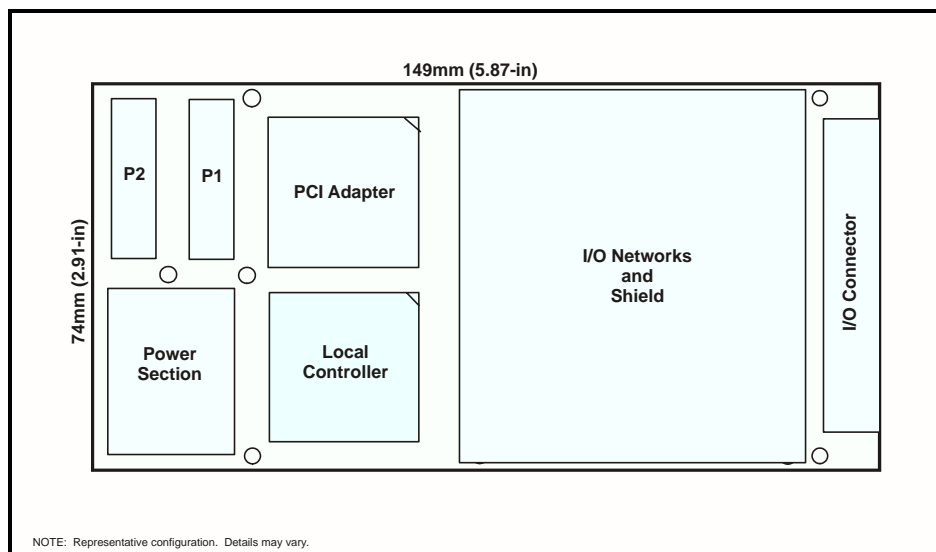

Figure 1.1-1. Physical Configuration

The board is designed for minimum off-line maintenance, and includes internal monitoring and autocalibration features that eliminate the need for disconnecting or removing the module from the system for calibration. All system input and output connections are made through a single 80-pin, dual-ribbon front-access I/O connector.

1.2 Functional Overview

Principal capabilities of the PMC66-16AI64SSA/C board are summarized in this list of features:

- ❑ 64 Single-Ended Simultaneously-Sampled 16-Bit Input Channels
- ❑ Software-Selectable Analog Input Ranges of $\pm 10V$, $\pm 5V$, $\pm 2.5V$, $0/+5V$ or $0/+10V$
- ❑ 512K-Sample Analog Input FIFO Buffer
- ❑ Selectable Differential Processing
- ❑ 200 KSPS per Channel Conversion Rate (12.8 MSPS Aggregate Rate)
- ❑ Dual Cascaded Internal Rate Generators
- ❑ Supports Synchronization of Multiple Boards
- ❑ Internal Autocalibration of all Analog Input Channels
- ❑ Mastering DMA Engine

The 16-Bit PMC66-16AI64SSA/C analog input board samples and digitizes 64 input channels simultaneously at rates up to 200,000 samples per second for each channel. The resulting 16-bit sampled data is available to the PCI bus through a 512K-Sample FIFO buffer. Each input channel contains a dedicated 16-Bit sampling ADC. All operational parameters are software configurable.

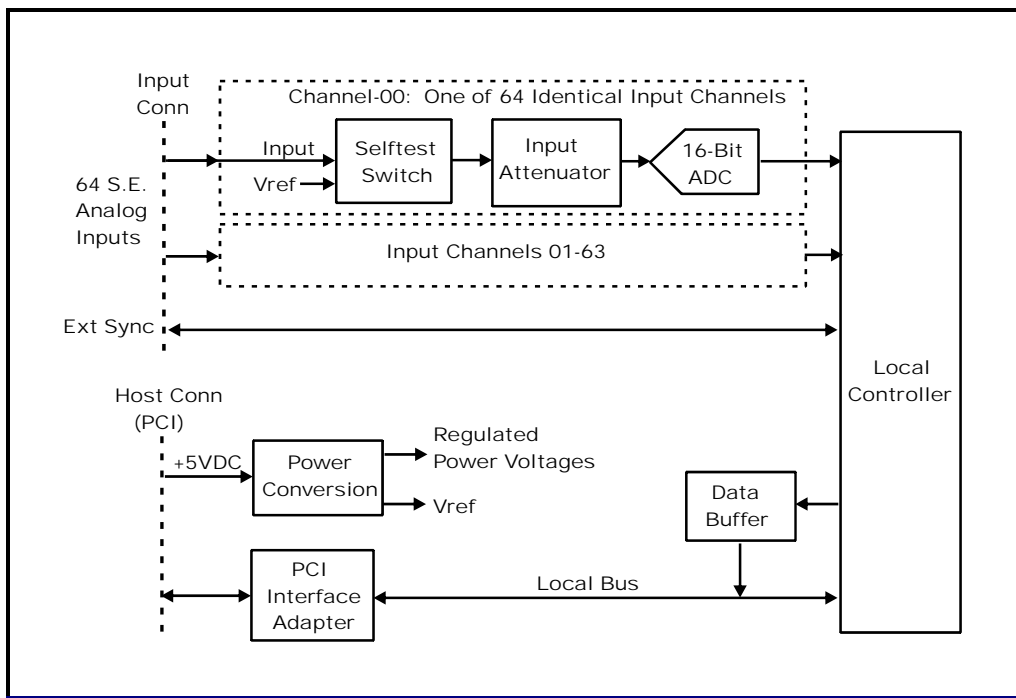

Figure 1.2-1. Functional Organization

Inputs can be sampled in groups of 2, 4, 8, 16, 32 or 64 channels, or any single channel can be sampled continuously. The sample clock can be generated from an internal rate generator, or directly through software, or by external hardware.

SECTION 2.0

INSTALLATION AND MAINTENANCE

2.1 Board Configuration

This product has no field-alterable configuration features, and is completely configured at the factory for field use.

2.2 Installation

2.2.1 Physical Installation

To minimize the opportunity for accidental damage before installation, the board should be stored in the original protective shipping envelope. System power must be turned OFF before proceeding with the installation.

CAUTION: This product is susceptible to damage from electrostatic discharge (ESD). Before removing the board from the conductive shipping envelope, ensure that the work surface, the installer and the host board have been properly discharged to ground.

After removing the board from the shipping envelope, position the board with the shield and standoffs facing the host (carrier) board, and with the I/O connector oriented toward the front panel. Align the two PCI connectors located at the end of the board opposite the I/O connector, with the mating connectors on the host board. Then carefully press the board into position on the host. Verify that the PCI connectors have mated completely and that the standoffs are seated against the host board.

Attach the board to the host with four 2.5 x 6.5mm panhead screws. Pass the screws through the back of the host into the four mounting holes on the board. Tighten the screws carefully to complete the installation. Do not overtighten.

2.2.2 Input/Output Cable Connections

System cable signal pin assignments are listed in Table 2.2-1. The I/O connector is designed to mate with an 80-pin dual-ribbon connector, equivalent to Robinson Nugent #P50E-080S-TG. The insulation displacement (IDC) Robinson Nugent cable connector accepts two 40-wire 0.050-inch ribbon cables, with the pin numbering convention shown in Table 2.2-1 and in Figure 2.2-1. Contact the factory if preassembled cables are required.

Table 2.2-1. System Connector Pin Functions

PIN	ROW-A SIGNAL
1	INP00
2	INP01
3	INP02
4	INP03
5	INPUT RTN
6	INP04
7	INP05
8	INP06
9	INP07
10	INPUT RTN
11	INP08
12	INP09
13	INP10
14	INP11
15	INPUT RTN
16	INP12
17	INP13
18	INP14
19	INP15
20	INPUT RTN
21	INP16
22	INP17
23	INP18
24	INP19
25	INPUT RTN
26	INP20
27	INP21
28	INP22
29	INP23
30	INPUT RTN
31	INP24
32	INP25
33	INP26
34	INP27
35	INPUT RTN
36	INP28
37	INP29
38	INP30
39	INP31
40	INPUT RTN

PIN	ROW-B SIGNAL
1	INP32
2	INP33
3	INP34
4	INP35
5	INPUT RTN
6	INP36
7	INP37
8	INP38
9	INP39
10	INPUT RTN
11	INP40
12	INP41
13	INP42
14	INP43
15	INPUT RTN
16	INP44
17	INP45
18	INP46
19	INP47
20	INP48
21	INPUT RTN
22	INP49
23	INP50
24	INP51
25	INP52
26	INP53
27	INPUT RTN
28	INP54
29	INP55
30	INP56
31	INP57
32	INP58
33	INPUT RTN
34	INP59
35	INP60
36	INP61
37	INP62
38	INP63
39	SYNC I/O RTN
40	SYNC I/O

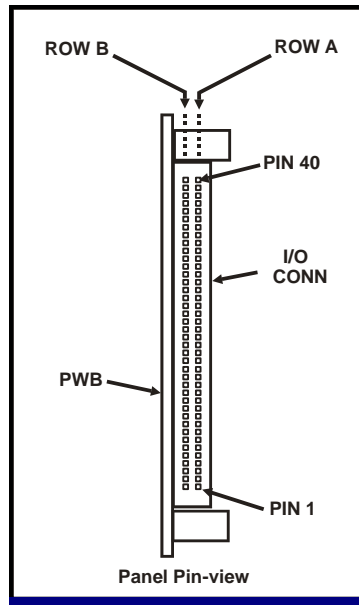

Figure 2.2-1. Input/Output Connector

2.3 System Configuration

2.3.1 Analog Inputs

Analog inputs INP00-INP63 (Table 2.2-1) can be configured as 1, 2, 4, 8, 16, 32 or 64 single-ended channels. Input configurations start at Channel-00, and proceed upward through consecutive channels to the highest-numbered channel in the configuration. The hardware input configuration must be acknowledged by the control software.

Single-ended inputs share a common input return that provides a return path for all inputs, making isolation from other system grounds a critical issue. If the signal sources are returned externally to system ground when operating in this mode, a potential difference between the system ground and input return can cause erroneous measurements, or may generate excessive ground current sufficient to damage the board.

A signal return pin (INPUT RTN) is provided in the I/O connector for every 4 or 5 input channels. If the signal sources are isolated from each other, and from system ground (Figure 2.3-1a), the returns in each 4 or 5 Channel group should be connected together at the source, and to at least one INPUT RTN pin in the connector.

For signal sources that have a common isolated return at the source (Figure 2.3-1b), the common return should be connected to at least one INPUT RTN pin for every 4 or 5 active input channels.

To minimize crosstalk between input channels at higher frequencies, all INPUT RTN pins should be connected to signal source returns. The INPUT-RTN pins are connected together internally within the board, and are electrically common to the system or PCibus ground.

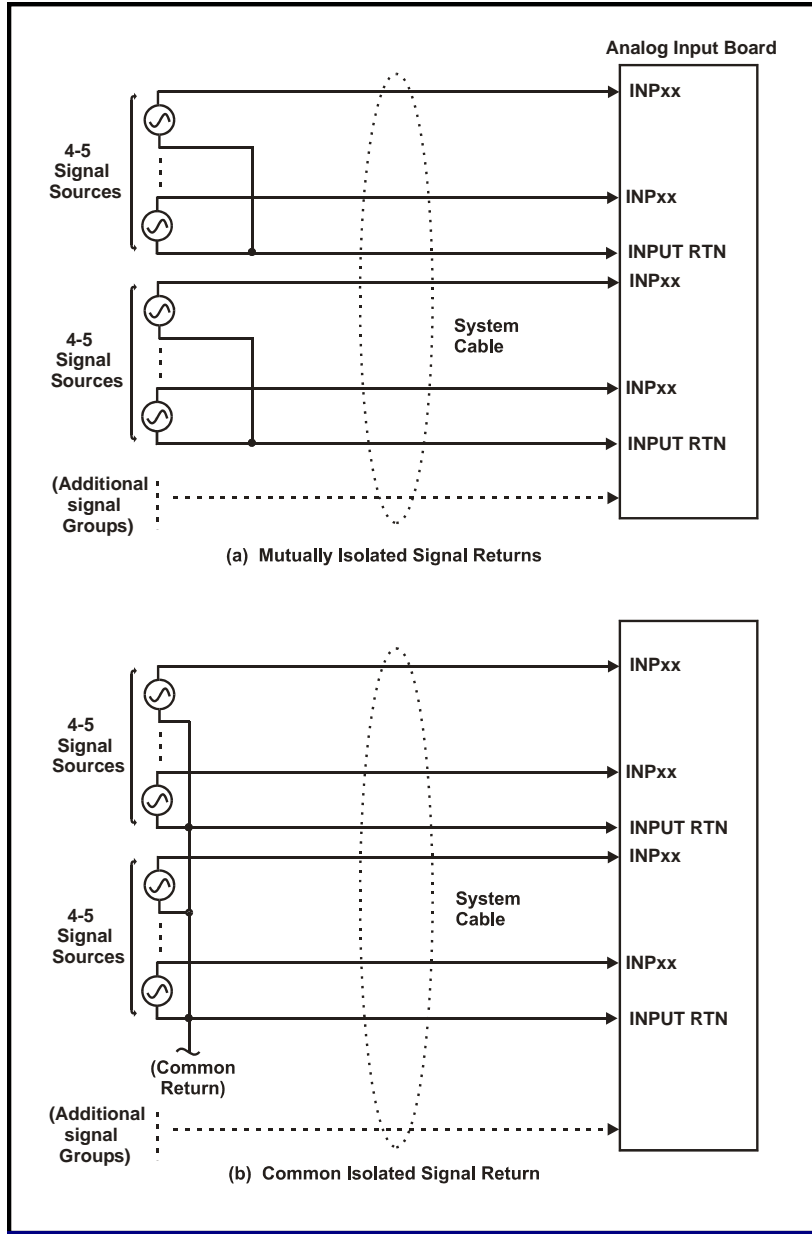

Figure 2.3-1. Analog Input Configurations

2.3.2 External Sync I/O

The SYNC I/O pin in the I/O connector is a bidirectional TTL synchronization signal that provides external control of analog input sample triggering. The SYNC I/O signal is referenced to the SYNC I/O RTN pin, which is connected internally to digital ground.

When configured as an input, this signal initiates a triggered sample of all active input channels. The SYNC I/O input is asserted LOW, and is pulled HIGH internally through a 4.7 KOhm resistor. Minimum input pulse width is 140ns.

When configured as an output, the SYNC I/O signal is asserted for approximately 160 nanoseconds at the beginning of each scan. The SYNC I/O output signal is a TTL level that can synchronize the operation of multiple target boards to a single initiator board. Like the SYNC I/O input signal, the SYNC I/O output signal is asserted LOW. Loading of the SYNC output should be limited to 10 milliamps or less.

Specific input/output configurations are determined by individual system requirements, and must be acknowledged by the control software.

NOTE: Refer to Paragraph 3.9 for auxiliary external sync provisions.

2.3.3 Multiboard Synchronization

If multiple boards are to be synchronized together, the SYNC I/O and SYNC I/O RTN pins from one board, the *initiator*, are connected to the SYNC I/O and SYNC I/O RTN pins of as many as four *target* boards (Figure 2.3-2). The controlling software determines specific synchronization functions.

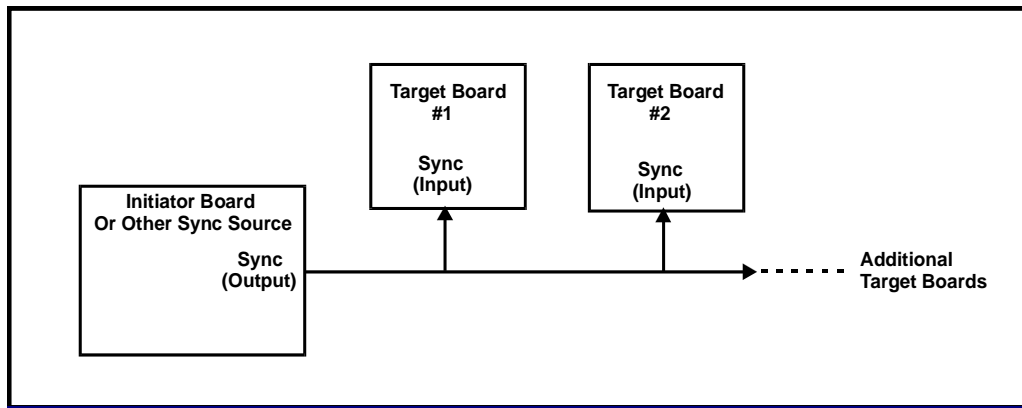

Figure 2.3-2. Multiboard Synchronization

2.4 Maintenance

This product requires no scheduled hardware maintenance other than periodic reference verification and possible adjustment. The optimum verification interval will vary, depending upon the specific application, but in most instances an interval of one year is sufficient.

In the event of a suspected malfunction, all associated system parameters, such as power voltages, control bus integrity, and system interface signal levels, should be evaluated before troubleshooting of the board itself is attempted. A board that has been determined to be defective should be returned to the factory for detailed problem analysis and repair.

2.5 Reference Verification

All analog input channels are software-calibrated to a single internal voltage reference by an embedded autocalibration software utility. The procedure presented here describes the verification and adjustment of the internal reference.

2.5.1 Equipment Required

Table 2.5-1 lists the equipment required for verifying or adjusting the internal reference. Alternative equivalent equipment may be used.

Table 2.5-1. Reference Verification Equipment

EQUIPMENT DESCRIPTION	MANUFACTURER	MODEL
Digital Multimeter, 5-1/2 digit, 0.005% accuracy for DC voltage measurements at ± 10 Volts.	Hewlett Packard	34401A
Host board with single-width PMC adapter	(Existing host)	---
Test cable; suitable for connecting the digital multimeter to two 0.024-inch square test posts.	---	---

2.5.2 Verification and Adjustment

The following procedure describes the verification of the single reference voltage that ensures conformance to the product specification. Adjustment of the internal reference, if necessary, is performed with an internal trimmer that is accessible as shown in Figure 2.5-1.

This procedure assumes that the board is installed on an operational host board.

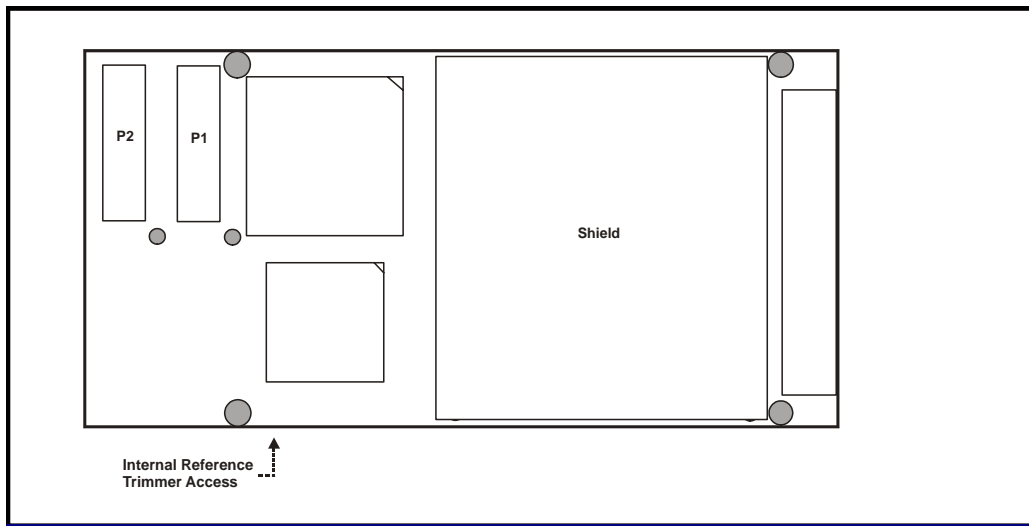

Figure 2.5-1. Reference Adjustment Access

PMC66-16AI64SSA/C

1. Connect the digital multimeter between VCAL_PFS (+) Pin-3, and REF RTN (-) Pin-4 in the J2 test connector.
2. If power has been removed from the board, apply power now. Wait at least 10 minutes after power is applied before proceeding..
3. Select the $\pm 10\text{V}$ input range.
4. Verify that the digital multimeter indication is $+9.9900\text{ VDC} \pm 0.0009\text{ VDC}$. If the indication is not within this range, adjust the INTERNAL REFERENCE trimmer until the digital multimeter indication is within the specified range.
5. Verification and adjustment is completed. Remove all test connections.

SECTION 3.0

CONTROL SOFTWARE

3.1 Introduction

The PMC66-16AI64SSA/C board is compatible with the PCI Local Bus specification, and supports auto-configuration at the time of power-up. A PLX™ PCI-9056 adapter operating in J-mode controls the PCI interface, and supports both 33MHz and 66MHz PCI clock frequencies, as well as D32 PCI bus width. Configuration-space registers are initialized internally to support the location of the board on any 16-longword boundary in memory space. After initialization has been completed, communication between the PCI bus and the local bus takes place through the control and data registers shown in Table 3.1-1. All local data transfers are long-word D32. Any of the predefined operational conditions identified throughout this section can invoke a single interrupt request from the board. DMA access is supported for data transfers from the analog input data buffer.

Table 3.1-1. Control and Data Registers

OFFSET (Hex)	REGISTER	ACCESS MODE*	DEFA ULT	PRIMARY FUNCTION
0000	BOARD CONTROL (BCR)	RW	0008 4060h	Board Control Register (BCR)
0004	INTERRUPT CONTROL	RW	0000 0008h	Interrupt conditions and flags
0008	INPUT DATA BUFFER	RO	000X XXXXh	Analog input data buffer
000C	INPUT BUFFER CONTROL	R/W	0003 FFFEh	Input buffer threshold and control
0010	RATE-A GENERATOR	RW	0001 0FA0h	Rate-A generator freq selection
0014	RATE-B GENERATOR	RW	0000 0050h	Rate-B generator freq selection
0018	BUFFER SIZE	RO	0000 0000h	Number of values in the input buffer
001C	BURST SIZE	R/W	0000 0001h	Number of sample clocks in a triggered burst.
0020	SCAN AND SYNC CONTROL	R/W	0000 0005h	Channels per scan; Clocking and Sync sources.
0024	ACTIVE CHANNEL ASSIGNMENT	R/W	0000 0100h	Specific first and last active channels.
0028	Board Configuration **	RO	000X XXXXh	Firmware revision and option straps.
002C	Autocal Values **	R/W	0000 080Xh	Autocal value readback.
0030	Auxiliary R/W Register **	R/W	0000 0000h	Auxiliary register. For internal use only.
0034	Auxiliary Sync I/O Control	R/W	0000 0000h	Controls auxiliary sync I/O port
0038	Scan Marker Upper Word	R/W	0000 0000h	Packed-data scan marker D[31..16].
003C	Scan Marker Lower Word	R/W	0000 0000h	Packed-data scan marker D[15..0]..

R/W = Read/Write, RO = Read-Only. ** Maintenance register; shown for reference only.

3.2 Board Control Register (BCR)

The Board Control Register (BCR) controls primary board functions, including analog input mode and range, and consists of 32 control bits and status flags. Table 3.2-1 provides a brief description of each bit field in the BCR, as well as indicating an associated section in the text.

Table 3.2-1. Board Control Register (BCR)

Offset: 0000h

Default: 0008 4060h

BIT	MODE	DESIGNATION	DEF	DESCRIPTION	REF
D00-D02	R/W	AIM[2..0]	0	Analog input mode. Selects system inputs or selftest mode. Defaults to System Inputs	3.5.3
D03	R/W	UNIPOLAR INPUTS	0	Selects unipolar inputs when HIGH, bipolar inputs when LOW.	3.4.1
D04-D05	R/W	RANGE[1..0]	2	Analog input range. Defaults to ±10V range.	3.4.1
D06	R/W	OFFSET BINARY	1	Selects offset-binary analog I/O data format when asserted HIGH, or two's complement when LOW.	3.5.1.2
D07	R/W	ENABLE EXTERNAL SYNC	0	Selects external sync I/O when HIGH.. (The Scan and Sync control register selects TARGET or INITIATOR mode). Not required for bursting (3.12)	3.9
D08-D09	R/W	DIFFERENTIAL PROCESSING	0	Selects standard or differential processing.	3.5.5
D10	R/W	(Reserved)	0	---	---
D11	R/W	DISABLE SCAN MARKER	0	Disables the scan marker in data packing mode.	3.11
D12	R/W	*INPUT SYNC	0	Triggers a single sample of all active channels when BCR Input Sync is selected in the Scan and Sync Control Register.	3.4.2
D13	R/W	*AUTOCAL	0	Initiates an autocalibration operation when asserted.	3.6
D14	RO	AUTOCAL PASS	1	Set HIGH at reset or autocal initialization. A HIGH state after autocal confirms a successful calibration.	3.6
D15	R/W	*INITIALIZE	0	Initializes the board when set HIGH. Sets all register defaults.	3.3.2
D16	R/W	BUFFER UNDERFLOW	0	Set HIGH if the buffer is read while empty. Cleared by direct write or by buffer clear.	3.5.2
D17	R/W	BUFFER OVERFLOW	0	Set HIGH if the buffer is written to when full. Cleared by direct write or by buffer clear.	3.5.2
D18	R/W	ENABLE DATA PACKING	0	Enables local-bus data packing	3.11
D19	R/W	AUTONOMOUS DEMAND MODE	1	Selects autonomous demand-mode DMA operation when HIGH, or Threshold-driven demand-mode DMA when LOW..	3.8
D20-D31	RO	(Reserved)	0	---	---

R/W = Read/Write, RO = Read-Only. *Clears automatically when operation is completed

3.3 Configuration and Initialization

3.3.1 Board Configuration

During *board configuration*, initial values for both the PCI configuration registers and the internal control logic are extracted from internal nonvolatile read-only memory. This process is initiated by a PCI bus reset, and should be required only once after the initial application of power. While the PCI configuration registers are being loaded, the response to PCI target accesses is RETRY's. Configuration operations are executed in the sequence shown in Table 3.3-1.

Table 3.3-1. Configuration Operations

Operation	Maximum Duration
PCI configuration registers are loaded from internal ROM	3 ms
Internal control logic is configured from internal ROM	300 ms
Internal control logic is initialized	3 ms

Loading of the PCI configuration registers is completed within 3 milliseconds after the assertion of a PCI bus reset, and should be required only once after the initial application of power. PCI register configuration terminates with the PCI interrupt disabled.

3.3.2 Initialization

Internal control logic can be initialized without reconfiguration of the PCI registers by setting the INITIALIZE control bit in the BCR. This action initializes the internal logic, but does not affect the PCI configuration registers and does not reconfigure the internal control logic. Initialization requires 3 milliseconds or less for completion, and produces the following default conditions:

- The BCR is initialized; all defaults are invoked,
- Analog input voltage range is ± 10 Volts,
- 32 channels are active,
- Input sample clocking is from the Rate-A generator at 12,500 samples per second,
- Analog input data coding format is offset binary; Data packing is disabled,
- The analog input buffer is reset to empty,
- Input rate generator Rate-A is disabled (Rate Generator Register D16 = HI).

Upon completion of initialization, the INITIALIZE control bit is cleared automatically.

3.4 Analog Input Parameters

3.4.1 Input Voltage Range

BCR control field RANGE[], as shown in Table 3.4-1 selects the analog input voltage range.

Table 3.4-1. Analog Voltage Range Selection

RANGE[1:0]	ANALOG INPUT RANGE
0	± 2.5 Volts
1	± 5 Volts
2	± 10 Volts
3	± 10 Volts

When the UNIPOLAR INPUTS control bit is HIGH in the BCR (Table 3.2-1), the $\pm 2.5V$ and $\pm 5V$ input ranges become 0/+5V and 0/+10V, respectively.

3.4.2 Timing Organization

Figure 3.4-1 illustrates the manner in which timing signals are organized within the board. The input sample clock selector is controlled by the Scan and Sync control register, which provides direct software control of clocking and sync operations. The external sync input and output line permits external control of timing. Two rate generators operate directly from the master clock frequency, or can be cascaded.

A sample clock can be generated by either rate generator, by the INPUT SYNC control bit in the BCR, or by an external sync source. Each Input Sample Clock triggers a sample of all active input channels. An active channel group can contain from two to 64 channels, or any single channel can be sampled individually. Each active channel group commences with Channel 00, and proceeds upward through consecutive channels to the selected number of channels.

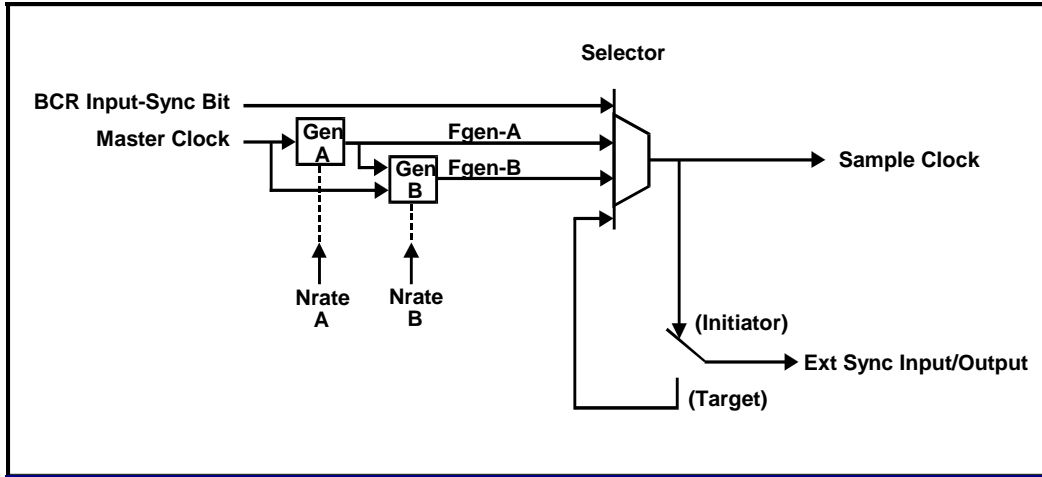

Figure 3.4-1. Clock and Sync Organization

3.4.3 Scan and Sync Control Register

The Scan and Sync control register (Table 3.4-2) controls the configuration of internal timing signals. The ACTIVE CHANNELS control field selects the number of active channels from two channels to 64 channels, or selects the single-channel mode if zero. (See Paragraph 3.5.5; Sampling Modes).

3.4.4 Sample Rate Generators

Each of the two rate generators consists of a 16-bit down-counter that divides the master clock frequency by a 16-bit integer contained in the associated rate register. The two rate registers are organized as shown in Table 3.4-3. Bits D00-D15 represent the frequency divisor **Nrate**, and D16 disables the associated generator when set HIGH. To prevent the input buffer from filling with extraneous data at power-up, D16 defaults to the HIGH state in the Rate-A control register.

3.4.4.1 Sample Rate Control

Each rate generator is controlled by a *divisor* **Nrate** that can be adjusted up to a maximum value of FFFFh (65535 decimal). With a master clock frequency of **Fclk** (MHz), the output frequency **Fgen** of each generator is determined as:

$$\mathbf{Fgen\ (Hz)\ =\ Fclk\ (Hz)\ /\ Nrate,}$$

where **Nrate** is the decimal equivalent of D00-D15 in the rate generator register. **Fgen** is the sampling frequency, and equals the rate at which all active channels are sampled. **Fclk** has a standard value of 50.000MHz, but may have other values depending upon custom ordering options.

The maximum sampling frequency **Fgen-max** is 200 kHz.

Table 3.4-2. Scan and Sync Control Register

Offset: 0020h

Default: 0000 0005h

DATA BIT	MODE	DESIGNATION	DEF	DESCRIPTION
D00-D02	R/W	ACTIVE CHANNELS	5	Number of active input channels: 0 => Single-Channel mode * 1 => 2 channels (00-01) 2 => 4 channels (00-03) 3 => 8 channels (00-07) 4 => 16 channels (00-15) 5 => 32 channels (00-31); Default value 6 => 64 channels (00-63) 7 => Channel group assignment (See Section 3.13) * Channel selected by Single-Channel Select field below.
D03-D04	R/W	SAMPLE CLOCK SOURCE	0	Selects the analog input sample clocking source: 0 => Internal Rate-A generator output 1 => Internal Rate-B generator output 2 => External Sync input line (Selects TARGET mode) 3 => BCR Input Sync control bit. (See also Triggered Burst, Section 3.12).
D05-D06	R/W	(Reserved)	0	---
D07	RO	BURST BUSY	0	Indicates a burst in progress.
D08-D09	R/W	BURST ON SYNC	0	Selects the triggered burst acquisition mode (Section 3.12)
D10	R/W	RATE-B CLOCK SOURCE	0	Selects the clock input source for the Rate-B generator: 0 => Master clock 1 => Rate-A generator output.
D11	R/W	(Reserved)	0	---
D12-17	R/W	SINGLE-CHANNEL SELECT	0	Selects the input channel number when operating in the Single-Channel scanning mode.
D18	R/W	(Reserved)	0	---
D19-D31	RO	(Reserved)	0	Inactive

R/W = Read/Write, RO = Read-Only.

Table 3.4-3. Rate Generator Register

Offset: 0010h (Rate-A), 0014h (Rate-B)

Default: 0001 0FA0 (Rate-A), 0000 0050h (Rate-B)

DATA BIT	MODE*	DESIGNATION	DEFAULT	DESCRIPTION
D00-D15	R/W	NRATE	---	Rate generator frequency control
D16	R/W	GENERATOR DISABLE	1	Disables the rate generator when HIGH
D17-D31	RO	(Inactive)	0	---

R/W = Read/Write, RO = Read-Only.

Table 3.4-4. Rate Generator Frequency Selection

Nrate (RATE[15..0])		FREQUENCY Fgen (30 MHz Master Clock)*
(Dec)	(Hex)	(Hz)
250	00FA	200,000
251	00FB	199,203
---	---	Fgen (Hz) = 50,000,000 / Nrate

* ±0.015 percent.

3.4.4.2 Generator Cascading

To provide very low sample rates, the Rate-B generator can be configured with the RATE-B CLOCK SOURCE control field to operate from the output of the Rate-A generator instead of from the master clock. When operating in this *cascaded* configuration, the output frequency of the Rate-B generator is:

$$F_{\text{gen-B}} (\text{Hz}) = F_{\text{clk}} / (N_{\text{rate-A}} * N_{\text{rate-B}}) ,$$

which can produce sample rates as low as 0.012 Hz with $F_{\text{clk}} = 50$ MHz.

3.4.5 Multiboard Synchronization

Multiple boards can be interconnected externally to produce synchronous analog input sampling. Figure 2.3-2 illustrates the interconnections required. External sync I/O is enabled by setting the ENABLE EXTERNAL SYNC control bit HIGH in the BCR. One of the boards is designated as the *Initiator*, and the remaining boards are designated as *targets*.

A board that is enabled for external sync I/O is designated as a **target** by selecting External Sync Input Line in the SAMPLE CLOCK SOURCE control field in the Scan and Sync control register. Any other value for this field designates the board as an **initiator**. The sync signal can originate either from an initiator board, or externally as an input to a group of targets.

If the ENABLE EXTERNAL SYNC control bit is set HIGH in the BCR, an initiator generates a sync pulse at the selected sample rate, and each of the target boards responds to the sync pulse by acquiring a single sample of all of its designated active channels.

NOTES: To avoid contention on the SYNC I/O line, all initiator/target designations should be assigned before enabling external sync I/O operation. No more than one board can be designated as an initiator.

For optimum autocalibration effectiveness at rates above 20KSPS, adjust the Rate-A Generator register to the same value on all boards.

Refer to Paragraph 3.9 for alternative external sync provisions.

3.5 Analog Input Control

3.5.1 Input Data Organization

Processed conversion data from the analog-to-digital converters (ADC's) flows directly into the 512K-sample analog input FIFO data buffer, and from the data buffer to the PCI bus as analog input data. The data buffer appears to the PCI bus as a single read-only register.

3.5.1.1 Input Data Buffer

Nonpacked analog input data is right-justified to the LSB, and occupies bit positions D00 through D15 (Table 3.5-1). D16 is HIGH for all Channel 00 values, and LOW for data from all other channels. Bits D17-D31 are always returned as zeros. An empty buffer returns an indeterminate value. Refer to Paragraph 3-11 for the configuration of packed data.

3.5.1.2 Data Coding Format

Analog input data is arranged as 16 active right-justified data bits with the coding conventions shown in Table 3.5-2. The default format is offset binary. Two's complement format is selected by clearing the OFFSET BINARY control bit LOW in the BCR. Unless indicated otherwise, offset binary coding is assumed throughout this document.

Refer to Section 3.11 for the effect of data packing on buffer contents.

Table 3.5-1. Input Data Buffer; Nonpacked Data

Offset: 0008h

Default: N/A

DATA BIT	MODE*	DESIGNATION	DESCRIPTION
D00	RO	DATA00	Least significant data bit
D01-D14	RO	DATA01 - DATA14	Intermediate data bits
D15	RO	DATA15	Most significant data bit
D16	RO	CHANNEL 00 TAG	Indicates a Channel-00 data value
D17-D31	RO	(Inactive)	---

* RO indicates read-only access. Write-data is ignored.

Table 3.5-2. Input Data Coding; 16-Bit Data

ANALOG INPUT LEVEL	DIGITAL VALUE (Hex)	
	OFFSET BINARY	TWO'S COMPLEMENT
Positive Full Scale minus 1 LSB	0000 FFFF	0000 7FFF
Zero	0000 8000	0000 0000
Zero minus 1 LSB	0000 7FFF	0000 FFFF
Negative Full Scale	0000 0000	0000 8000

3.5.2 Input Data Buffer Control

The Input Data Buffer control register shown in Table 3.5-3 controls and monitors the flow of data through the analog input data buffer. Asserting the CLEAR BUFFER control bit HIGH clears, or empties, the buffer. The Threshold Flag is HIGH when the number of values in the input data buffer **exceeds the input threshold value** defined by bits D00-D17, and is LOW if the number is equal to or less than the threshold value. An interrupt (Section 3.7) can be programmed to occur on either the rising or falling edge of the threshold flag.

Input data is discarded if the DISABLE BUFFER control bit is set HIGH, but data already present in the buffer is unaffected and can be accessed from the PCIbus.

The Buffer Size register shown in Table 3.5-4 contains the number of input values present in the buffer, and is updated continuously.

Buffer underflow and overflow flags in the BCR indicate that the buffer has been read while empty or written to when full. Each of these situations is indicative of data loss. Once set HIGH, each flag remains HIGH until cleared, either by directly clearing the bit LOW or by clearing the buffer or initializing the board.

Table 3.5-3. Input Data Buffer Control Register

Offset: 000Ch

Default: 0003 FFEh

DATA BIT	MODE*	DESIGNATION	DEF	DESCRIPTION
D00-D17	R/W	THRESHOLD VALUE	FFFEh	Input buffer threshold value.
D18	R/W	CLEAR BUFFER *	0	Clears (empties) the input buffer and processing pipeline when asserted HIGH.
D19	RO	THRESHOLD FLAG	0	Asserted HIGH when the number of values in the input buffer exceeds the THRESHOLD VALUE.
D19-D31	RO	(Inactive)	0	---

*Clears automatically within 200ns of being set

Table 3.5-4. Buffer Size Register

Offset: 0018h

Default: 0000 0000h

DATA BIT	MODE*	DESIGNATION	DEF	DESCRIPTION
D00-D17	RO	BUFFER SIZE	00000h	Number of values in the input buffer
D18-D31	RO	(Inactive)	0	---

3.5.3 Analog Input Function Modes

BCR control field AIM[] selects the analog input signal source, and provides selftest modes for monitoring the integrity of the analog input networks. Table 3.5-5 summarizes the input function modes.

3.5.3.1 System Analog Inputs

With the default value of 'Zero' selected for the AIM[] field in the BCR, all ADC channels are connected to the system analog inputs from the system I/O connector.

Table 3.5-5. Analog Input Function Selection

AIM[2:0]	FUNCTION OR MODE
0	System analog input mode (Default mode).
1	(Reserved)
2	ZERO test. Internal ground reference is connected to all analog input channels.
3	+VREF test. Internal voltage reference is connected to all analog input channels.
4-7	(Reserved)

3.5.3.2 Selftest Modes

In the selftest modes, the analog input lines from the system I/O connector are ignored and have no effect on selftest results. Specified board accuracy applies to all selftest measurements, and the averaged values of multiple samples should be used for critical measurements.

The ZERO selftest applies a Zero reference signal to all input channels, and should produce a nominal midscale reading of 0000 8000h for bipolar inputs, or 0000 0000h for unipolar inputs. For the +VREF test, a precision reference voltage is applied to all inputs. **The +VREF reference voltage equals 99.90% of the positive fullscale value (nominally 0000 FFDFh) for bipolar ranges, or 49.95% (nominally 0000 7FDF)for unipolar ranges.**

3.5.4 Sampling Modes

The analog inputs can be sampled in groups of 2, 4, 8, 16, 32 or 64 active channels, or any single channel can be selected for digitizing. The number of active channels is selected by the ACTIVE CHANNELS[] field in the scan and sync control register. Each active channel group commences with Channel-00, and proceeds upward through successive channels to the selected number of channels.

For Single-Channel sampling (ACTIVE CHANNELS[] = 0), the channel to be digitized is selected by the SINGLE-CHANNEL SELECT control field.

NOTE: Refer to Section 3.13 to designate a specific group of active channels.

3.5.5 Differential Processing

Although the hardware inputs are single-ended in nature, differential processing allows the inputs to appear as either pseudo-differential or full-differential channels. Each of these processing modes is characterized by the reference from which the signal in each channel is measured. Differential processing is selected by the DIFFERENTIAL PROCESSING control field in the BCR as shown in Table 3.5-6.

Table 3.5-6. Differential Processing Modes

BCR D08,09	Designation	Processing Function
0	SINGLE ENDED	Default operating mode. Processing of input data is limited to gain and offset error correction.
1	PSEUDO-DIFFERENTIAL	Channel-00 is the input LO reference for all other channels.
2	FULL DIFFERENTIAL	Each odd-numbered channel is the LO reference for each even-numbered HI channel. I.e.: Channels 00 and 01 become Channel-00 HI and Channel-00 LO, respectively.
3	(Reserved)	

3.5.5.1 Default Single-Ended Processing

For single-ended channels, each input signal is measured with respect to the common input return. That is, each channel reports the difference between the input signal voltage and the voltage present on the common input return. This configuration provides the maximum number of input channels, but allows noise and other forms of interference on the common return line to appear in the signal measurement.

3.5.5.2 Pseudo-Differential Mode

Pseudo-differential processing designates input Channel-00 as the reference for all other channels, and subtracts the sampled value in Channel-00 from the sampled values in all other channels. With this arrangement, noise and interference on the common return line is essentially cancelled, and the Channel-00 input line can be used as a 'remote sense' line for Channels 01-63. ***Channel-00 can no longer be used as a measurement channel when operating in this mode, and appears in the acquisition sequence with a zero-level value.***

3.5.5.3 Full Differential Mode

If full-differential processing is selected, each odd-numbered channel becomes the reference level for the associated even-numbered channel. For example, Channel-01 becomes the reference for Channel-00, and Channel-00 data is reported as the difference between the actual Channel-00 input signal and the signal in Channel-01. ***Odd-numbered channels do not appear in the data buffer when operating in full-differential mode, which reduces the number of data channels to one-half the selected number of active channels.***

Note: Because the same signal is applied to all channels simultaneously when a selftest operation is selected (3.5.3.2), selftest always produces a zero-level when operating in either differential processing mode.

3.5.5.4 Differential Scaling Considerations

Because differential processing operates by subtracting the signal values in two channels, all input ranges are effectively doubled when either differential mode is selected. With the $\pm 10V$ range and pseudo-differential operation selected for example, Channel-00 data can have any value from -10V to +10V, and all channels using Channel-00 as a reference also have the same range of values. The difference signal then can have any value from -20V to +20V, and the effective input range becomes $\pm 20V$.

Note: Although differential processing effectively doubles the output data range, the hardware input levels are still restricted to the selected input range.

In addition to doubling the effective input voltage range, differential processing also always produces a bipolar output signal. Since a reference channel can have a value that is greater than or less than that in a signal channel, ***differentially processed data is always bipolar in nature.***

3.6 Autocalibration

To obtain maximum measurement accuracy, autocalibration should be performed after:

- Power warmup or a PCIbus reset,
- Input range change,
- Sample rate change, if greater than 20 kHz.

A small error, on the order of 0.04-percent, can be introduced when the input range is changed, or when a large change (>20 kHz) occurs in the sample rate. Performing autocalibration with the required sample rate selected eliminates this error.

During autocalibration, no control settings are altered and external analog input signals are ignored.

Autocalibration is invoked by setting the AUTOCAL control bit HIGH in the BCR. The control bit returns LOW automatically at the end of autocalibration. Autocalibration can be invoked at any time, and has a duration of approximately 0.5 second. Completion of the operation can be detected either by selecting the 'Autocalibration Operation Completed' interrupt condition (paragraph 3.7) and waiting for the interrupt request, or by simply waiting a sufficient amount of time to ensure that autocalibration has been completed.

To compensate for component aging, and to minimize the effects of temperature on accuracy, the autocalibration function determines the optimum calibration values for current conditions, and stores the necessary correction values in volatile memory. If a board is defective, the autocalibration process may be unable to successfully calibrate the inputs. If this situation occurs, the AUTOCAL PASS status bit in the BCR is cleared LOW at the end of the autocalibration interval, and remains LOW until a subsequent initialization or autocalibration occurs. AUTOCAL PASS is initialized HIGH, and remains HIGH unless an autocalibration failure occurs.

NOTE: For synchronous multiple-board operation at rates above 20KSPS, adjust the Rate-A Generator register to the same value on all boards (3.4.4.2).

3.7 Interrupt Control

In order for the board to generate a PCI interrupt, *both* of the following conditions must occur:

- a. The internal controller must generate a Local Interrupt Request (Section 3.7.1)
- b. The *PCI interrupt* must be enabled (Section 3.7.2).

A local interrupt request will not generate a PCI bus interrupt unless the PCI interrupt has been enabled as described in Paragraph 3.7.2.

3.7.1 Local Interrupt Request

The Interrupt Control Register shown in Table 3.7-1 controls the single local interrupt request line. Two simultaneous source conditions (IRQ 0 and 1) are available for the request, with multiple conditions available for each source. IRQ 0 and 1 are logically OR'd together to produce the single interrupt available to the board.

When one or more selected conditions occur for either of the IRQ's, a local interrupt request is generated and the associated IRQ REQUEST flag bit is set HIGH. The request remains asserted until the PCI bus clears the request flag. A local interrupt request is generated automatically at the end of initialization, through IRQ0.

Interrupt conditions are *edge-sensitive*, and an interrupt request is generated if, and only if, a specific interrupt condition undergoes a *transition* from 'false' (not-true) to 'true' while that condition is selected.

3.7.2 Enabling the PCI Interrupt

A local interrupt request will not produce an interrupt on the PCI bus unless the PCI interrupt is enabled. The PCI interrupt is enabled by setting the *PCI Interrupt Enable* and *Local Interrupt Input Enable* control bits HIGH in the *Runtime Interrupt Control/Status Register* described in Section 6 of the PLX™ PCI-9056 reference manual..

Table 3.7-1. Interrupt Control Register

Offset: 0000 0004h

Default: 0000 0008h

DATA BIT	MODE	DESIGNATION	DEF	VALUE	INTERRUPT EVENT
D00-02	R/W	IRQ0 A0,1,2	0	0	Idle. Interrupt disabled unless initializing. Default state after reset.
				1	Autocalibration operation completed
				2	Input sample initiated (Sync)
				3	Input sample completed (data ready)
				4	Triggered burst initiated (BURST BUSY => HI)
				5	Triggered burst completed (BURST BUSY => LO)
				6-7	(Reserved)
D03	R/W	IRQ0 REQUEST	1*	---	Group 0 interrupt request flag. Set HIGH when the selected interrupt condition occurs. Clears the request when cleared LOW by the bus.
D04-06	R/W	IRQ1 A0,1	0	0	Idle; no interrupt condition selected.
				1	Input buffer threshold LOW-HIGH transition
				2	Input buffer threshold HIGH-LOW transition
				3	Input buffer overflow or underflow
				4-7	(Reserved)
D07	R/W	IRQ1 REQUEST	0	---	Group 1 interrupt request flag. See D03.
D08-31	RO	(Inactive)	0	---	

R/W = Read/Write, RO = Read-Only. * HIGH after reset.

3.8 DMA Operation

DMA transfers from the analog input buffer are supported with the board operating as a bus master, in either DMA Channel 00 or Channel 01. Set bit D[02] in the PCI Command register HIGH to select the bus mastering mode. Also, clear D[15] LOW in the PCI-9056 DMA Mode register to select *slow-terminate* operation. Refer to the PCI-9056 reference manual for a detailed description of DMA configuration registers.

3.8.1 Block Mode

Table 3.8-1 illustrates a *typical* PCI register configuration that would control a non-chaining, non-incrementing **block-mode** DMA transfer in DMA Channel 00, in which a PCI interrupt is generated when the transfer has been completed. For typical applications, the DMA Command Status Register would be initialized to 0000 0001h, and then changed to 0000 0003h to initiate a transfer.

Table 3.8-1. Typical DMA Registers; Block Mode

PCI Offset	PCI Register	Function	Typical Value
80h	DMA Mode	Bus width (32); Interrupt on done	0002 0D43h
84h	DMA PCI Address	Initial PCI data source address	*
88h	DMA Local Address	Initial (constant) local address	0000 0008h
8Ch	DMA Transfer Byte Count	Number of bytes in transfer	*
90h	DMA Descriptor Counter	Transfer direction (Local bus to PCI bus)	0000 0008h
A8h (D7:0)	DMA Command/Status	Command and Status Register	01h, 03h (See Text)

* Determined by specific transfer requirements.

NOTE: *Block-mode* DMA can be implemented regardless of the state of the AUTONOMOUS DEMAND MODE control bit in the BCR.

3.8.2 Demand Mode

Demand mode transfers are controlled in a manner similar to block mode transfers, with the addition of **demand-mode** operation selected in the DMA mode register (D[12] = HIGH). Demand mode operation also requires the **slow terminate** mode (D[15] = LOW), which is the default state for this control bit. Table 3.8-2 shows a *typical* PCI register configuration for DMA Channel 00 demand mode operation.

Table 3.8-2. Typical DMA Registers; Demand Mode

PCI Offset	PCI Register	Function	Typical Value
80h	DMA Mode	Bus width (32)	0002 1943h
84h	DMA PCI Address	Initial PCI data source address	*
88h	DMA Local Address	Initial (constant) local address	0000 0008h
90h	DMA Descriptor Counter	Transfer direction (Local bus to PCI bus)	0000 0008h
A8h (D7:0)	DMA Command/Status	Command and Status Register	01h, 03h (See Text)

* Determined by specific transfer requirements.

3.8.2.1 Autonomous (Firmware revisions 200h and higher; See Table 3.10-1.)

This mode is selected if the AUTONOMOUS DEMAND MODE control bit is HIGH in the BCR (the default condition). When operating in this mode, DMA data transfer from the input buffer is requested continuously as long as the buffer contains data. If the control bit is LOW, then Threshold-Flag Driven demand-mode DMA operation is selected (3.8.2.2).

NOTE: The PCI-9056 adapter extracts data from the 32-Bit (Lword) local bus in 64-Bit (quad-word) increments. Consequently, if the buffer runs empty or nearly empty in the autonomous mode, the situation can arise in which the last one or two samples in an active channel group are retained in the buffer until subsequent data is acquired. If this occurs, the next sample set flushes the retained data through the PCI-9056 adapter to the PCI bus, and no samples are lost.

3.8.2.2 Threshold-Flag Driven

This mode is similar to autonomous DMA, except a DMA transfer request is initiated *only* when the number of values in the buffer **exceeds the threshold value** selected for the buffer. The threshold-flag driven DMA request is sustained until one of the following events occurs:

- The data buffer goes empty,
- The number of values read from the buffer equals the threshold value plus one,
- The buffer is cleared,
- The board is reset,
- Autocalibration is executed.

The DMA request is terminated at the first occurrence of any of these events.

3.9 Auxiliary External Sync I/O

Four auxiliary external connections provide an alternate method of synchronizing sample clocking to external events when the ENABLE EXTERNAL SYNC control bit is HIGH in the BCR. These TTL connections are available as AUX-0 through AUX-3 (Table 3.9-1), and are accessible both through a 6-Pin header on one edge of the board, and through the two PMC PCI-interface connectors P1 and P2.

Table 3.9-1. Auxiliary Sync I/O Connections

SIGNAL	PIN *	PMC CONN PIN
AUX-0	1	P1-41
AUX-1	2	P1-42
AUX-2	3	P2-10
AUX-3	4	P2-34
RETURN	5,6	(PCI GND)

* 2-Row 2mm right-angle header.

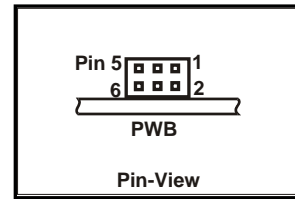

Figure 3.9-1. Auxiliary Sync Header

AUX sync signals are designated independently through the Auxiliary Sync I/O Control register as inputs, outputs, or inactive, as indicated in Table 3.9-2. When an AUX signal is designated as an *input*, the signal replaces the SYNC IO input from the system connector, and the board must be configured as a sync **target** in the Scan and Sync control register (Table 3.4-2). If multiple AUX signals are designated as active inputs, the inputs are logically OR'd together internally. 'Inactive' and 'Active Input' AUX lines are pulled to +5VDC through 4.7K.

Active AUX *outputs* produce an output pulse for each ADC sample clock, and are active in both target and initiator external sync modes. Source and sink load capacity of each output is 15 milliamps.

To increase the reliability of external triggering in high-noise environments, selectable noise suppression increases the debounce or detection interval for active inputs, and increases the pulse width of active outputs.

Table 3.9-2. Auxiliary Sync I/O Control

Offset: 0000 0034h

Default: 0000 0000h

DATA BIT	MODE	DESIGNATION	DEFAULT	DESCRIPTION
D00-01	R/W	AUX-0 Control Mode	0	AUX-0 I/O Control Mode: 0 => Inactive 1 => Active Input (LO-to-HI edge) 2 => Active Output (Positive pulse) 3 => (Reserved)
D02-03	R/W	AUX-1 Control Mode	0	AUX-1 I/O Control Mode *
D04-05	R/W	AUX-2 Control Mode	0	AUX-2 I/O Control Mode *
D06-07	R/W	AUX-3 Control Mode	0	AUX-3 I/O Control Mode *
D08	R/W	INVERT INPUTS	0	Active inputs are detected on the LO-to-HI edge when this bit is LOW, or on the HI-to-LO edge when this bit is HIGH.
D09	R/W	INVERT OUTPUTS	0	Active outputs produce HIGH pulses when this bit is LOW, or LOW pulses when this bit is HIGH.
D10	R/W	NOISE SUPPRESSION	0	When LOW, input debounce time is 100ns-135ns and output pulse width is 135ns. When HIGH, input debounce time is 1.5us, and output pulse width is 2.0us.
D11-31	RO	(Reserved)	0	Read-back as all-zero.

* Same configuration as AUX-0.

Some applications may require the scan marker code to be absolutely unique and not appear randomly in the data. To support this requirement, an all-zero marker code (0000 0000h) causes every all-zero data value (0000h) to be forced to a unit code (0001h) when data packing is enabled. This arrangement supports the uniqueness requirement without affecting the differential nonlinearity of the data itself.

3.12 Triggered Bursts

When the BURST ON SYNC control field is nonzero in the Scan and Sync control register (Table 3.4-2), the context of a sync event changes from "sample on sync" to "burst on sync." In the "sample on sync" context, a sync event initiates a single sample of all active channels (See Sections 3.4.2 and 3.4.5). In the "burst on sync" context, a sync event initiates a **burst** of internal sample clocks, each of which produces a sample of all active channels. This function is available in firmware revisions 0200h through 04FFh (3.10).

3.12.1 Burst Size and Trigger Source

The number of sample clocks issued during a burst is controlled by the 20-bit **Burst Size control register** listed in Table 3.1-1, which has a range from 1 to 1,048,575 sample clocks. For Burst-Size values of one or greater, the number of sample clocks in a burst equals the value in the register. For example, if a burst size of 10 is selected while 16 channels are active, then each burst will contain 160 sample values. Selection of the burst trigger source is summarized in Table 3.12-1. A Burst-Size of zero produces a burst that extends continuously until stopped, either by disabling the internal clock or by clearing the BURST ON SYNC control field.

Table 3.12-1. Burst Trigger Source

Scan and Sync Register BURST ON SYNC	Burst Trigger Source	Sync I/O Pin
0	Bursting disabled.	(Sample-Clock I/O)
1	Rate-B generator.	Trigger Output *
2	External Sync I/O input pin (or AUX input)	Trigger Input *
3	INPUT SYNC control bit in the BCR.	Trigger Output *

* Independent of BCR control bit ENABLE EXTERNAL SYNC.

The Sync I/O pin in the system I/O connector can operate as an input or output trigger pin. The trigger output can serve as a burst trigger for target boards in which the BURST ON SYNC control field selects the external Sync I/O pin as a trigger source. The burst trigger selection supersedes the sample clock selection for control of the external Sync-I/O pin.

NOTE: During a triggered burst the BURST BUSY status flag in the Scan and Sync control register goes HIGH at the trigger event, and returns LOW at the end of the burst. Either edge of the BURST BUSY flag is selectable as an interrupt event (Table 3.7-1).

3.12.2 Sample Clock Source

When operating in the triggered-burst mode, the sample-clock source is selected by the SAMPLE CLOCK SOURCE field in the Scan and Sync control register. The single restriction on the sample clock source is that the burst trigger and the sample clock can not use the same source simultaneously.

The following sequence illustrates the setup for a typical burst operation:

1. Select the input range, sample-clock source and burst size, with clocking disabled,
2. Select the burst trigger source (enables burst triggering),
3. Clear the buffer, then enable clocking.

3.13 Active Channel Group Assignment

If "Channel group assignment" is selected in the ACTIVE CHANNELS field in the Scan and Sync control register (Table 3.4-2), the first and last active channels are defined by the Active Channels Assignment control register shown in Table 3.13-1. The group of active channels is *contiguous*, beginning with the channel designated by the FIRST CHANNEL SELECT field, and proceeding upward through consecutive channels to (and including) the channel designated by LAST CHANNEL SELECT. The LAST CHANNEL SELECT field must be greater than the FIRST CHANNEL SELECT field.

Table 3.13-1. Active Channel Assignment

Offset: 0000 0024h

Default: 0000 0100h

DATA BIT	MODE	DESIGNATION	DEFAULT	DESCRIPTION
D00-D07	R/W	FIRST CHANNEL SELECT	0	First (lowest-numbered) active channel
D08-D15	R/W	LAST CHANNEL SELECT	1	Last (highest-numbered) active channel
D16-D31	RO	(Reserved)	0	Inactive. Returns all-zero.

When this method is used for selecting active channels, the context of the "Channel-00 tag" flag in the data buffer (Table 3.5-1) changes to "First-Channel tag." For example, if FIRST CHANNEL SELECT = 05, then D16 in the buffer will be HIGH for Channel-05 data, and LOW otherwise. This context change applies also to the scan marker (Section 3.11).

NOTE: Because Channel-00 is used as the differential reference for all other input channels in the pseudo-differential processing mode (3.5.5.2), Channel-00 must always be the First Channel when operating in the pseudo-differential mode.

Similarly, when operating in the full-differential mode (3.5.5.3), the First and Last Channels must always be even-numbered and odd-numbered channels, respectively.

This function is available in firmware revisions 100h and higher (3.10).

SECTION 4.0

PRINCIPLES OF OPERATION

4.1 General Description

Each of 64 single-ended analog input channels contains a dedicated 16-Bit ADC, an input attenuator, and a selftest input switching network (Figure 4.1-1). A PCI interface adapter provides the interface between the controlling PCI bus and an internal local controller. +5 VDC power from the PCibus is converted into regulated power voltages for the internal analog networks. Differential processing supports pseudo-differential and full-differential processing modes.

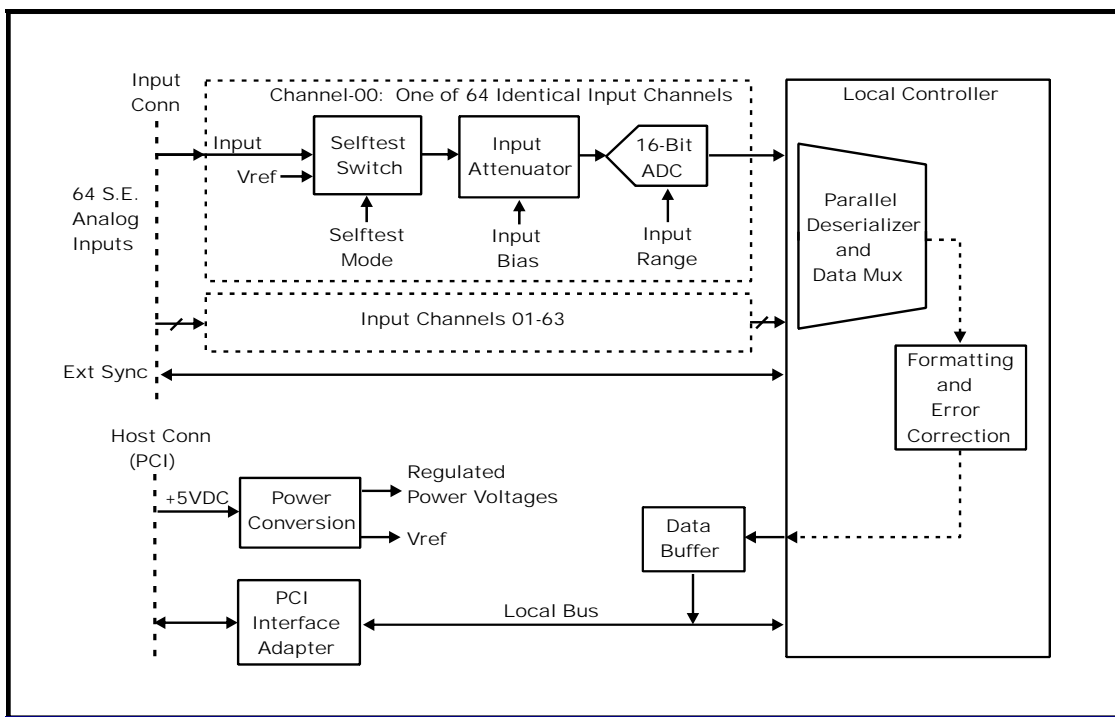

Figure 4.1-1. Functional Block Diagram

Selftest switches at the inputs provide test signals for autocalibration of all input channels, and the input attenuator is biased to accept bipolar input ranges. The input range is controlled by adjusting the 16-Bit ADC reference voltage. Each input sample is corrected for gain and offset errors with calibration values determined during autocalibration. A 512 Ksample FIFO buffer accumulates analog input data for subsequent retrieval by a PMC host.

Analog input sampling on multiple target boards can be synchronized to a single software-designated initiator board. An interrupt request can be generated in response to selected conditions, including the status of the analog input data buffer.

4.2 Analog Inputs

Analog-to-digital conversions can be performed on signals from any of several sources, which are selected by the selftest switches shown in Figure 4.1-1. During normal operation, the ADC's receive system analog input signals from the input connector. For selftest and autocalibration operations, the internal voltage reference can be routed through the selftest switches to the ADC. An input attenuator in each channel provides the necessary scaling and offset parameters to support bipolar input ranges.

Serial data from each ADC is deserialized and multiplexed into a parallel data stream within the local controller. The output of the data multiplexer passes through a digital processor that applies gain and offset correction values obtained during autocalibration. The corrected data is formatted, a tag is attached to all Channel-00 data, and the data is finally loaded into the input of the analog input data buffer.

4.3 Rate Generators

The local controller contains two independent rate generators, each of which divides a master clock frequency by a software-controlled 16-bit integer. Either generator can be assigned as a clocking source for the analog inputs, and the generators can be cascaded to produce very long clocking intervals.

4.4 Data Buffer

A 512K-sample FIFO buffer accumulates analog input data for subsequent retrieval through the PCIbus. The buffer is supported by a 'size' register that tracks the number of values in the buffer, and by a threshold flag that can be used to generate an interrupt request when the number of values in the buffer moves above or below a selected count.

4.5 Autocalibration

Autocalibration is an embedded firmware utility that calibrates all analog input channels to a single internal voltage reference. The utility can be invoked at any time by the control software.

An internal voltage reference is used to calibrate the span of each channel, and a zero-reference is used to calibrate the offset value. Correction values determined during autocalibration are applied to each digitized sample that is acquired during acquisition. Correction values are retained until the autocalibration sequence is repeated, or until power is removed.

4.6 Power Control

Regulated supply voltages of +5 VDC and ± 15 VDC are required for internal analog networks, and are derived from the +5-Volt input provided by the PCI bus, both by switching preregulators and by linear postregulators.

APPENDIX A

Local Control Register Quick Reference

APPENDIX A Local Control Register Quick Reference

This appendix summarizes the local registers and principal control-bit fields described in Section 3.

Table 3.1-1. Control and Data Registers

OFFSET (Hex)	REGISTER	ACCESS MODE*	DEFA ULT	PRIMARY FUNCTION
0000	BOARD CONTROL (BCR)	RW	0008 4060h	Board Control Register (BCR)
0004	INTERRUPT CONTROL	RW	0000 0008h	Interrupt conditions and flags
0008	INPUT DATA BUFFER	RO	000X XXXXh	Analog input data buffer
000C	INPUT BUFFER CONTROL	R/W	0003 FFFEh	Input buffer threshold and control
0010	RATE-A GENERATOR	RW	0001 0FA0h	Rate-A generator freq selection
0014	RATE-B GENERATOR	RW	0000 0050h	Rate-B generator freq selection
0018	BUFFER SIZE	RO	0000 0000h	Number of values in the input buffer
001C	BURST SIZE	R/W	0000 0001h	Number of sample clocks in a triggered burst.
0020	SCAN AND SYNC CONTROL	R/W	0000 0005h	Channels per scan; Clocking and Sync sources.
0024	ACTIVE CHANNEL ASSIGNMENT	R/W	0000 0100h	Specific first and last active channels.
0028	Board Configuration **	RO	000X XXXXh	Firmware revision and option straps.
002C	Autocal Values **	R/W	0000 080Xh	Autocal value readback.
0030	Auxiliary R/W Register **	R/W	0000 0000h	Auxiliary register. For internal use only.
0034	Auxiliary Sync I/O Control	R/W	0000 0000h	Controls auxiliary sync I/O port
0038	Scan Marker Upper Word	R/W	0000 0000h	Packed-data scan marker D[31..16].
003C	Scan Marker Lower Word	R/W	0000 0000h	Packed-data scan marker D[15..0].

R/W = Read/Write, RO = Read-Only. ** Maintenance register; shown for reference only.

Table 3.2-1. Board Control Register (BCR)

Offset: 0000h

Default: 0008 4060h

BIT	MODE	DESIGNATION	DEF	DESCRIPTION	REF
D00-D02	R/W	AIM[2..0]	0	Analog input mode. Selects system inputs or selftest mode. Defaults to System Inputs	3.5.3
D03	R/W	UNIPOLAR INPUTS	0	Selects unipolar inputs when HIGH, bipolar inputs when LOW.	3.4.1
D04-D05	R/W	RANGE[1..0]	2	Analog input range. Defaults to $\pm 10V$ range.	3.4.1
D06	R/W	OFFSET BINARY	1	Selects offset-binary analog I/O data format when asserted HIGH, or two's complement when LOW.	3.5.1.2
D07	R/W	ENABLE EXTERNAL SYNC	0	Selects external sync I/O when HIGH.. (The Scan and Sync control register selects TARGET or INITIATOR mode). Not required for bursting (3.12)	3.9
D08-D09	R/W	DIFFERENTIAL PROCESSING	0	Selects standard or differential processing.	3.5.5
D10	R/W	(Reserved)	0	---	---
D11	R/W	DISABLE SCAN MARKER	0	Disables the scan marker in data packing mode.	3.11
D12	R/W	*INPUT SYNC	0	Triggers a single sample of all active channels when BCR Input Sync is selected in the Scan and Sync Control Register.	3.4.2
D13	R/W	*AUTOCAL	0	Initiates an autocalibration operation when asserted.	3.6
D14	RO	AUTOCAL PASS	1	Set HIGH at reset or autocal initialization. A HIGH state after autocal confirms a successful calibration.	3.6
D15	R/W	*INITIALIZE	0	Initializes the board when set HIGH. Sets all register defaults.	3.3.2
D16	R/W	BUFFER UNDERFLOW	0	Set HIGH if the buffer is read while empty. Cleared by direct write or by buffer clear.	3.5.2
D17	R/W	BUFFER OVERFLOW	0	Set HIGH if the buffer is written to when full. Cleared by direct write or by buffer clear.	3.5.2
D18	R/W	ENABLE DATA PACKING	0	Enables local-bus data packing	3.11
D19	R/W	AUTONOMOUS DEMAND MODE	1	Selects autonomous demand-mode DMA operation when HIGH, or Threshold-driven demand-mode DMA when LOW..	3.8
D20-D31	RO	(Reserved)	0	---	---

R/W = Read/Write, RO = Read-Only. *Clears automatically when operation is completed

Table 3.4-1. Analog Voltage Range Selection (BCR field)

RANGE[1:0]	ANALOG INPUT RANGE
0	± 2.5 Volts
1	± 5 Volts
2	± 10 Volts
3	± 10 Volts

Table 3.4-2. Scan and Sync Control Register

Offset: 0020h

Default: 0000 0005h

DATA BIT	MODE	DESIGNATION	DEF	DESCRIPTION
D00-D02	R/W	ACTIVE CHANNELS	5	Number of active input channels: 0 => Single-Channel mode * 1 => 2 channels (00-01) 2 => 4 channels (00-03) 3 => 8 channels (00-07) 4 => 16 channels (00-15) 5 => 32 channels (00-31); Default value 6 => 64 channels (00-63) 7 => Channel group assignment (See Section 3.13) * Channel selected by Single-Channel Select field below.
D03-D04	R/W	SAMPLE CLOCK SOURCE	0	Selects the analog input sample clocking source: 0 => Internal Rate-A generator output 1 => Internal Rate-B generator output 2 => External Sync input line (Selects TARGET mode) 3 => BCR Input Sync control bit. (See also Triggered Burst, Section 3.12).
D05-D06	R/W	(Reserved)	0	---
D07	RO	BURST BUSY	0	Indicates a burst in progress.
D08-D09	R/W	BURST ON SYNC	0	Selects the triggered burst acquisition mode (Section 3.12)
D10	R/W	RATE-B CLOCK SOURCE	0	Selects the clock input source for the Rate-B generator: 0 => Master clock 1 => Rate-A generator output.
D11	R/W	(Reserved)	0	---
D12-17	R/W	SINGLE-CHANNEL SELECT	0	Selects the input channel number when operating in the Single-Channel scanning mode.
D18	R/W	(Reserved)	0	---
D19-D31	RO	(Reserved)	0	Inactive

R/W = Read/Write, RO = Read-Only.

Table 3.4-3. Rate Generator Register

Offset: 0010h (Rate-A), 0014h (Rate-B)

Default: 0001 0FA0 (Rate-A), 0000 0050h (Rate-B)

DATA BIT	MODE*	DESIGNATION	DEFAULT	DESCRIPTION
D00-D15	R/W	NRATE	---	Rate generator frequency control
D16	R/W	GENERATOR DISABLE	1	Disables the rate generator when HIGH
D17-D31	RO	(Inactive)	0	---

R/W = Read/Write, RO = Read-Only.

Table 3.4-4. Rate Generator Frequency Selection

Nrate (RATE[15..0])		FREQUENCY Fgen (30 MHz Master Clock)*
(Dec)	(Hex)	(Hz)
250	00FA	200,000
251	00FB	199,203
---	---	Fgen (Hz) = 50,000,000 / Nrate

Table 3.5-1. Input Data Buffer

Offset: 0008h

Default: N/A

DATA BIT	MODE*	DESIGNATION	DESCRIPTION
D00	RO	DATA00	Least significant data bit
D01-D14	RO	DATA01 - DATA14	Intermediate data bits
D15	RO	DATA15	Most significant data bit
D16	RO	CHANNEL 00 TAG	Indicates a Channel-00 data value
D17-D31	RO	(Inactive)	---

* RO indicates read-only access. Write-data is ignored.

Table 3.5-2. Input Data Coding; 16-Bit Data

ANALOG INPUT LEVEL	DIGITAL VALUE (Hex)	
	OFFSET BINARY	TWO'S COMPLEMENT
Positive Full Scale minus 1 LSB	0000 FFFF	0000 7FFF
Zero	0000 8000	0000 0000
Zero minus 1 LSB	0000 7FFF	0000 FFFF
Negative Full Scale	0000 0000	0000 8000

Table 3.5-3. Input Data Buffer Control Register

Offset: 000Ch

Default: 0003 FFFEh

DATA BIT	MODE*	DESIGNATION	DEF	DESCRIPTION
D00-D17	R/W	THRESHOLD VALUE	FFFEh	Input buffer threshold value.
D18	R/W	CLEAR BUFFER *	0	Clears (empties) the input buffer and processing pipeline when asserted HIGH.
D19	RO	THRESHOLD FLAG	0	Asserted HIGH when the number of values in the input buffer exceeds the THRESHOLD VALUE.
D19-D31	RO	(Inactive)	0	---

*Clears automatically within 200ns of being set

Table 3.5-4. Buffer Size Register

Offset: 0018h

Default: 0000 0000h

DATA BIT	MODE	DESIGNATION	DEF	DESCRIPTION
D00-D17	RO	BUFFER SIZE	00000h	Number of values in the input buffer
D18-D31	RO	(Inactive)	0	---

Table 3.5-5. Analog Input Function Selection (BCR field)

AIM[2:0]	FUNCTION OR MODE
0	System analog input mode (Default mode).
1	(Reserved)
2	ZERO test. Internal ground reference is connected to all analog input channels.
3	+VREF test. Internal voltage reference is connected to all analog input channels.
4-7	(Reserved)

Table 3.5-6. Differential Processing Modes

BCR D08,09	Designation	Processing Function
0	SINGLE ENDED	Default operating mode. Processing of input data is limited to gain and offset error correction.
1	PSEUDO-DIFFERENTIAL	Channel-00 is the input LO reference for all other channels.
2	FULL DIFFERENTIAL	Each odd-numbered channel is the LO reference for each even-numbered HI channel. I.e.: Channels 00 and 01 become Channel-00 HI and Channel-00 LO, respectively.
3	(Reserved)	

Table 3.7-1. Interrupt Control Register

Offset: 0000 0004h

Default: 0000 0008h

DATA BIT	MODE	DESIGNATION	DEF	VALUE	INTERRUPT EVENT
D00-02	R/W	IRQ0 A0,1,2	0	0	Idle. Interrupt disabled unless initializing. Default state after reset.
				1	Autocalibration operation completed
				2	Input sample initiated (Sync)
				3	Input sample completed (data ready)
				4	Triggered burst initiated (BURST BUSY => HI)
				5	Triggered burst completed (BURST BUSY => LO)
D03	R/W	IRQ0 REQUEST	1*	---	Group 0 interrupt request flag. Set HIGH when the selected interrupt condition occurs. Clears the request when cleared LOW by the bus.
D04-06	R/W	IRQ1 A0,1	0	0	Idle; no interrupt condition selected.
				1	Input buffer threshold LOW-HIGH transition
				2	Input buffer threshold HIGH-LOW transition
				3	Input buffer overflow or underflow
D07	R/W	IRQ1 REQUEST	0	---	Group 1 interrupt request flag. See D03.
D08-31	RO	(Inactive)	0	---	

R/W = Read/Write, RO = Read-Only. * HIGH after reset.

Table 3.8-1. Typical DMA Registers; Block Mode

PCI Offset	PCI Register	Function	Typical Value
80h	DMA Mode	Bus width (32); Interrupt on done	0002 0D43h
84h	DMA PCI Address	Initial PCI data source address	*
88h	DMA Local Address	Initial (constant) local address	0000 0008h
8Ch	DMA Transfer Byte Count	Number of bytes in transfer	*
90h	DMA Descriptor Counter	Transfer direction (Local bus to PCI bus)	0000 0008h
A8h (D7:0)	DMA Command/Status	Command and Status Register	01h, 03h (See Text)

* Determined by specific transfer requirements.

Table 3.8-2. Typical DMA Registers; Demand Mode

PCI Offset	PCI Register	Function	Typical Value
80h	DMA Mode	Bus width (32)	0002 1943h
84h	DMA PCI Address	Initial PCI data source address	*
88h	DMA Local Address	Initial (constant) local address	0000 0008h
90h	DMA Descriptor Counter	Transfer direction (Local bus to PCI bus)	0000 0008h
A8h (D7:0)	DMA Command/Status	Command and Status Register	01h, 03h (See Text)

* Determined by specific transfer requirements.

Table 3.9-1. Auxiliary Sync I/O Connections

SIGNAL	PIN *	PMC CONN PIN
AUX-0	1	P1-41
AUX-1	2	P1-42
AUX-2	3	P2-10
AUX-3	4	P2-34
RETURN	5,6	(PCI GND)

* 2-Row 2mm right-angle header.

Table 3.9-2. Auxiliary Sync I/O Control

Offset: 0000 0034h

Default: 0000 0000h

DATA BIT	MODE	DESIGNATION	DEFAULT	DESCRIPTION
D00-01	R/W	AUX-0 Control Mode	0	AUX-0 I/O Control Mode: 0 => Inactive 1 => Active Input (LO-to-HI edge) 2 => Active Output (Positive pulse) 3 => (Reserved)
D02-03	R/W	AUX-1 Control Mode	0	AUX-1 I/O Control Mode *
D04-05	R/W	AUX-2 Control Mode	0	AUX-2 I/O Control Mode *
D06-07	R/W	AUX-3 Control Mode	0	AUX-3 I/O Control Mode *
D08	R/W	INVERT INPUTS	0	Active inputs are detected on the LO-to-HI edge when this bit is LOW, or on the HI-to-LO edge when this bit is HIGH.
D09	R/W	INVERT OUTPUTS	0	Active outputs produce HIGH pulses when this bit is LOW, or LOW pulses when this bit is HIGH.
D10	R/W	NOISE SUPPRESSION	0	When LOW, input debounce time is 100ns-135ns and output pulse width is 135ns. When HIGH, input debounce time is 1.5us, and output pulse width is 2.0us.
D11-31	RO	(Reserved)	0	Read-back as all-zero.

* Same configuration as AUX-0.

Table 3.10-1. Board Configuration Register

Offset: 0000 0028h

Default: 000X XXXXh

BIT FIELD	DESCRIPTION
D00-D11	Firmware Revision
D12-D15	(Reserved status flags).
D16	High if the board contains only 32 input channels.
D17-D18	Describes Master Clock Frequency Fclk as: 0 => 50.000 MHz 1 => 45.000 MHz 2 => 49.152 MHz 3 => 51.840 MHz
D19-D31	(Reserved)

Table 3.11-1. Data Packing

Buffer Lword Order	Buffer Data Field					
	ENABLE DATA PACKING = 0 DISABLE SCAN MARKER = X		ENABLE DATA PACKING = 1 DISABLE SCAN MARKER = 0		ENABLE DATA PACKING = 1 DISABLE SCAN MARKER = 1	
	D[31..16]	D[15..0]	D[31..16]	D[15..0]	D[15..0]	D[15..0]
00	0001h	Chan 00 Data	Upper Marker	Lower Marker	Chan 01 Data	Chan 00 Data
01	0000h	Chan 01 Data	Chan 01 Data	Chan 00 Data	Chan 03 Data	Chan 02 Data
02	0000h	Chan 02 Data	Chan 03 Data	Chan 02 Data	Chan 05 Data	Chan 04 Data
03	0000h	Chan 03 Data	Chan 05 Data	Chan 04 Data	Chan 07 Data	Chan 06 Data
---	---	---	---	---	---	---

Table 3.12-1. Burst Trigger Source

Scan and Sync Register BURST ON SYNC	Burst Trigger Source	Sync I/O Pin
0	Bursting disabled.	(Sample-Clock I/O)
1	Rate-B generator.	Trigger Output *
2	External Sync I/O input pin (or AUX input)	Trigger Input *
3	INPUT SYNC control bit in the BCR.	Trigger Output *

* Independent of BCR control bit ENABLE EXTERNAL SYNC.

Table 3.13-1. Active Channel Assignment

Offset: 0000 0024h

Default: 0000 0100h

DATA BIT	MODE	DESIGNATION	DEFAULT	DESCRIPTION
D00-D07	R/W	FIRST CHANNEL SELECT	0	First (lowest-numbered) active channel
D08-D15	R/W	LAST CHANNEL SELECT	1	Last (highest-numbered) active channel
D16-D31	RO	(Reserved)	0	Inactive. Returns all-zero.

APPENDIX B

Migration From PMC-16AI64SS

Appendix B

Migration From PMC-16AI64SS

Operation of the PMC66-16AI64SSA/C is similar to that of the PMC-16AI64SS. This appendix summarizes the principal similarities and differences between the two products, and is provided as a general guide rather than a definitive list of requirements.

B.1. Comparison of Features

Table B.1 provides a brief comparison of PMC-16AI64SS and PMC66-16AI64SSA/C features. The two products differ principally with respect to the width of the local buffer's data field, 66MHz PCI compatibility, and increased local clock frequency.

Table B.1. PMC-16AI64SS, PMC66-16AI64SSA/C Features Comparison

Feature	PMC-16AI64SS	PMC66-16AI64SSA/C
Number of Channels	64	64
Conversion Resolution	16 Bits	16 Bits
Data Buffer	256K-Sample FIFO	512K-Sample FIFO
Buffer Data Field	17 Active bits	32 Active bits
PCI Interface	PCI 2.3; D32; 33MHz	PCI 2.3; D32; 33MHz/66MHz
Local Clock	30 MHz	50 MHz

B.2. Migration Issues

Paragraph 3.1. Introduction:

A 66 MHz PCI-9056 adapter replaces the 33 MHz PCI-9080.

Table 3.1-1. Control and Data Registers:

Register default values and the nomenclature of Scan Marker registers are revised.

Table 3.2-1. Board Control Register:

Bit D18 designation is changed to ENABLE DATA PACKING.

Paragraph 3.4.4.1. Sample Rate Control:

Table 3.4-4. Rate Generator Frequency Selection:

The local clock frequency is increased from 30 MHz to 50 MHz.

Paragraph 3.5.2. Input Data Buffer Control:

Table 3.5-4. Input Data Buffer Control Register:

The THRESHOLD VALUE is extended to 18 Bits, and the THRESHOLD X4 and DISABLE BUFFER control functions are deleted.

B.2. Migration Issues (Continued)

Paragraph 3.8. DMA Operation:

PCI-9056 demand mode operation is available in both threshold-flag driven and autonomous modes.

Paragraph 3.11. Data Packing:

Table 3.11-1. Data Packing:

Revised for 32-Bit local bus and local data packing.

Paragraph 3.12. Triggered Bursts:

New feature.

Paragraph 3.13 Active Channel Group Assignment:

New feature.

Revision History:

092807:	
Table 3.2-1:	Revised definition of control bit D19.
Table 3.7-1:	Added event "buffer underflow or overflow".
Para 3.8:	Added autonomous demand-mode DMA.

Copyright (C) 2006 General Standards Corp.

Additional copies of this manual or other General Standards Co. literature may be obtained from:

General Standards Corp.
8302A Whitesburg Dr.
Huntsville, Alabama 35802
Telephone: (256) 880-8787
FAX: (256) 880-8788

The information in this document is subject to change without notice.

General Standards Corp. makes no warranty of any kind with regard to this material, including, but not limited to, the implied warranties of merchantability and fitness for a particular purpose. Although extensive editing and reviews are performed before release to ECO control, General Standards Corp. assumes no responsibility for any errors that may exist in this document. No commitment is made to update or keep current the information contained in this document.

General Standards Corp. does not assume any liability arising out of the application or use of any product or circuit described herein, nor is any license conveyed under any patent rights or any rights of others.

General Standards Corp. assumes no responsibility resulting from omissions or errors in this manual, or from the use of information contained herein.

General Standards Corp. reserves the right to make any changes, without notice, to this product to improve reliability, performance, function, or design.

All rights reserved.

No part of this document may be copied or reproduced in any form or by any means without prior written consent of General Standards Corp.

General Standards Corporation
High Performance Bus Interface Solutions