

Camera Interface Discussion

September 1, 2005

Sheng Peng (pengs@slac.stanford.edu)

LCLS Control Group

Applications

- We will have many applications which need camera
 - Injection Laser Stabilization
 - OTR
 - ...
- The data throughput may be very high
 - $640 \times 480 \times 2 \text{ bytes/pixel} \times 120 \text{ Hz} \approx 74 \text{ MB/s}$
 - Even we average every 4 pulses, the data rate will be $\sim 19 \text{ MB/s}$
 - If we work at 10Hz, the data rate will be $\sim 6.5 \text{ MB/s}$
 - $1400 \times 100 \times 2 \text{ bytes/pixel} \times 120 = 33.6 \text{ MB/s}$
- Theoretical throughput
 - Giga-Ethernet: $\sim 100 \text{ MB/s}$
 - 32-Bit 66MHz PCI: 264 MB/s
 - 64-Bit 66MHz PCI: 528 MB/s

September 1, 2005

Sheng Peng (pengs@slac.stanford.edu)

LCLS Control Group

Camera Interfaces

- Today's camera has couple of popular interfaces:
 - Cameralink (2.38Gbps)
 - Ethernet (1Gbps)
 - LVDS(RS-644) (1.923Gbps)
 - USB2.0 (480Mbps)
 - Firewire (400Mbps/800Mbps)
- The camera we will use are all Cameralink interface so far
- We have two methods to integrate Cameralink interface into our control system: Ethernet or PMC Frame Grabber

PULNiX Cam2net/DALSA Netlink



Cameralink, up to 10 meters



Giga-Ethernet Point-to-Point Link



September 1, 2005

Sheng Peng (pengs@slac.stanford.edu)

LCLS Control Group

PULNiX Cam2net/DALSA Netlink

■ Pros

- Easy to connect
- Easy to reconfigure if it is not P2P
- Everyone loves Ethernet include me

September 1, 2005

Sheng Peng (pengs@slac.stanford.edu)

LCLS Control Group

PULNiX Cam2net/DALSA Netlink

■ Cons

- Such constantly high data rate is a big challenge for Ethernet. The existing vendor solution is proprietary Ethernet driver for PC with Intel 8254x chip only.
- The communication protocol of cam2net is not released to us yet.
- To upload images, VMEBus is too slow. We can have PMC based fiber channel, but it is too expensive. So only choice is still Ethernet.
- MVME6100 has two Giga-Ethernet ports. If one was occupied by camera, then all other traffic such as uploading image and Channel Access will have to share another.
- Having both Giga-Ethernet ports working at such high load sounds impossible, right? Maybe uploading image doesn't have to be real-time in any case.

PULNiX Cam2net/DALSA Netlink

■ Cost

- Cam2net costs ~\$1200
- Cameralink cable is ~\$150
- If it is P2P link, no switch port cost.
- Cisco Giga-Ethernet switch is ~\$200/port without 10G uplink
- Cisco Giga-Ethernet switch is ~\$700/port with 10G uplink

PMC Frame Grabber

- Many vendors have PMC Frame Grabber
 - Analog? No
 - 64-Bit/66MHz PMC? Good. Money? :-(
 - Only one vendor found
 - \$5000 per card without software
 - \$4000 for vxWorks compiled library
 - Source code costs more
 - 32-Bit/66MHz PMC? Good and affordable.
 - EDT is the only vendor which is willing to supply source code and programming interface for free.
 - EDT tested their PMC with the camera we bought

EDT PMC DV C-Link



Cameralink, up to 10 meters

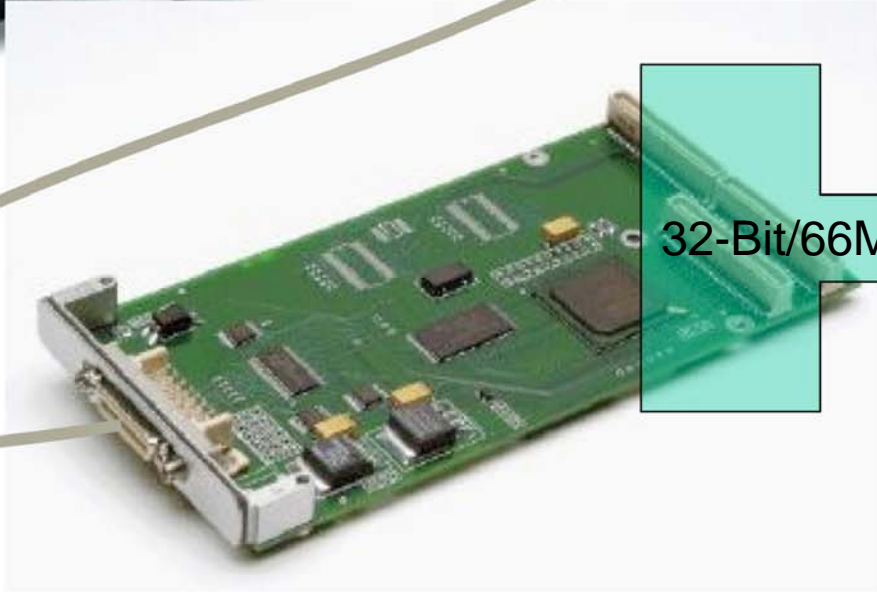

32-Bit/66MHz PMC Interface

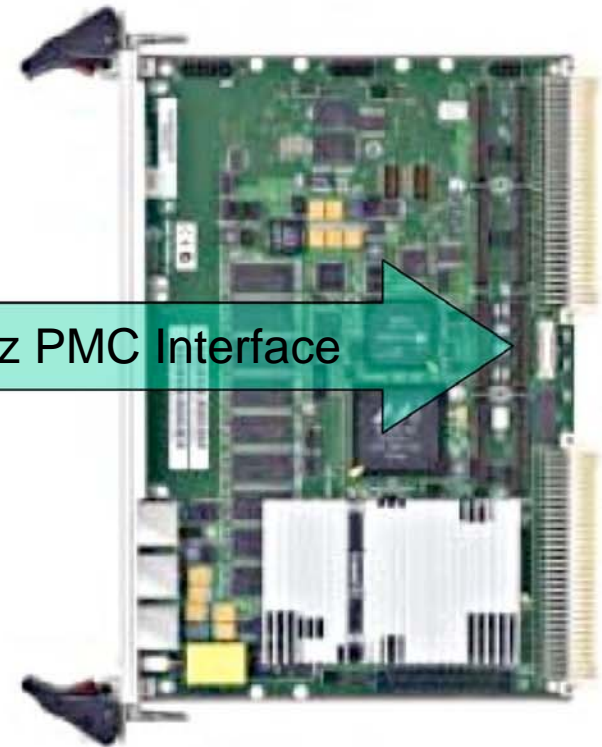

September 1, 2005

Sheng Peng (pengs@slac.stanford.edu)

LCLS Control Group

EDT PMC DV C-Link

■ Pros

- Data throughput over PMC DMA is promised
- We will have one Giga-Ethernet port dedicate to uploading image
- Source code for vxWorks will be available. Porting it to RTEMS should be easier than start from scratch
- Compatibility with PULNiX TM-6710CL is already proved
- Bytes order handled by hardware which saves a lot of CPU time

September 1, 2005

Sheng Peng (pings@slac.stanford.edu)

LCLS Control Group

EDT PMC DV C-Link

■ Cons

- Cable length could be a problem. But there is a way to address it.
- Cabling is not as easy as Ethernet
- Camera can not be reassigned to different IOC without rewiring

EDT PMC DV C-Link

■ Cost

- PMC DV C-Link is \$895
- Cameralink cable is ~\$150
- A pair of Cameralink \Leftrightarrow Fiber cost ~\$1600.
This will allow us to talk to a camera within 300 meters without repeater. No Cameralink cable is needed anymore.

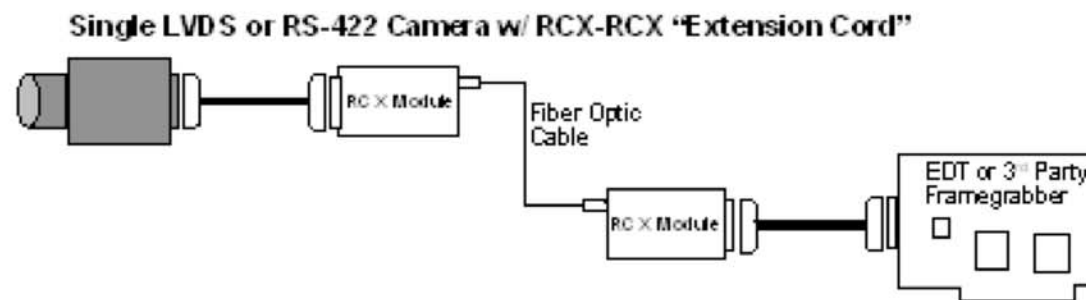

EDT PMC Varieties

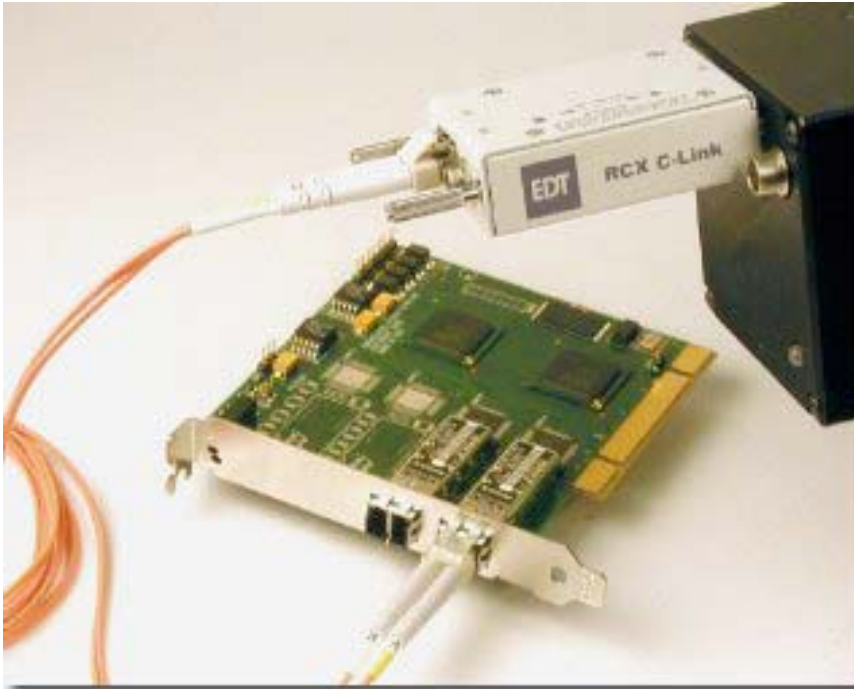

A fiber repeater could be built into PMC. So the same data could be delivered to a PCI frame grabber in PC without bothering IOC. The cost will be ~\$1250 per PMC card.

- EDT is willing to design a PMC card with fiber interface for us.
 - We need only one Cameralink => Fiber instead of a pair, save \$800
 - ~\$1000 per PMC card instead of \$895
 - \$5000 NRE required
 - Fiber interface is not standard as Cameralink
 - Programming interface stays same

September 1, 2005

Sheng Peng (pengs@slac.stanford.edu)

LCLS Control Group