



Installation Instructions

ControlLogix EtherNet/IP Bridge Module

Catalog Number 1756-ENBT

Use this document as a guide to install the module. Note that this document describes hardware installation only. For configuration information, refer to the EtherNet/IP Modules User Manual, publication number ENET-UM001, available online at www.rockwellautomation.com/literature.

The following table lists the contents of this document and where to find specific information.

Topic	See Page
Important User Information	2
Identify Module Components	7
Prepare the Chassis for Module Installation	8
Determine Module Slot Location	9
Install the Module in the Chassis	10
Remove or Replace the Module (when applicable)	11
Install or Remove the Module Under Power	12
Wire the Ethernet Connector	13
Connect the Module to the EtherNet/IP Network	13
Apply Chassis Power	15
Check Power Supply and Module Status	15
Troubleshoot the Module	16
Where to Find Information on Configuring the Module	17
Specifications	18

Important User Information

Solid state equipment has operational characteristics differing from those of electromechanical equipment. *Safety Guidelines for the Application, Installation and Maintenance of Solid State Controls* (Publication SGI-1.1 available from your local Rockwell Automation sales office or online at <http://www.ab.com/manuals/gi>) describes some important differences between solid state equipment and hard-wired electromechanical devices. Because of this difference, and also because of the wide variety of uses for solid state equipment, all persons responsible for applying this equipment must satisfy themselves that each intended application of this equipment is acceptable.





In no event will Rockwell Automation, Inc. be responsible or liable for indirect or consequential damages resulting from the use or application of this equipment.

The examples and diagrams in this manual are included solely for illustrative purposes. Because of the many variables and requirements associated with any particular installation, Rockwell Automation, Inc. cannot assume responsibility or liability for actual use based on the examples and diagrams.

No patent liability is assumed by Rockwell Automation, Inc. with respect to use of information, circuits, equipment, or software described in this manual.

Reproduction of the contents of this manual, in whole or in part, without written permission of Rockwell Automation, Inc. is prohibited.

Throughout this manual, when necessary we use notes to make you aware of safety considerations.

 WARNING	Identifies information about practices or circumstances that can cause an explosion in a hazardous environment, which may lead to personal injury or death, property damage, or economic loss.
IMPORTANT	Identifies information that is critical for successful application and understanding of the product.
 ATTENTION	Identifies information about practices or circumstances that can lead to personal injury or death, property damage, or economic loss. Attentions help you: <ul style="list-style-type: none">• identify a hazard• avoid a hazard• recognize the consequence
 SHOCK HAZARD	Labels may be located on or inside the equipment (e.g., drive or motor) to alert people that dangerous voltage may be present.
 BURN HAZARD	Labels may be located on or inside the equipment (e.g., drive or motor) to alert people that surfaces may be dangerous temperatures.

Environment and Enclosure

ATTENTION

This equipment is intended for use in a Pollution Degree 2 industrial environment, in overvoltage Category II applications (as defined in IEC publication 60664-1), at altitudes up to 2000 meters without derating.

This equipment is considered Group 1, Class A industrial equipment according to IEC/CISPR Publication 11. Without appropriate precautions, there may be potential difficulties ensuring electromagnetic compatibility in other environments due to conducted as well as radiated disturbance.

This equipment is supplied as "open type" equipment. It must be mounted within an enclosure that is suitably designed for those specific environmental conditions that will be present and appropriately designed to prevent personal injury resulting from accessibility to live parts. The interior of the enclosure must be accessible only by the use of a tool. Subsequent sections of this publication may contain additional information regarding specific enclosure type ratings that are required to comply with certain product safety certifications.

NOTE: See NEMA Standards publication 250 and IEC publication 60529, as applicable, for explanations of the degrees of protection provided by different types of enclosure. Also, see the appropriate sections in this publication, as well as the Allen-Bradley publication 1770-4.1 ("Industrial Automation Wiring and Grounding Guidelines"), for additional installation requirements pertaining to this equipment.

Prevent Electrostatic Discharge

ATTENTION

This equipment is sensitive to electrostatic discharge, which can cause internal damage and affect normal operation. Follow these guidelines when you handle this equipment:

- Touch a grounded object to discharge potential static.
 - Wear an approved grounding wriststrap.
 - Do not touch connectors or pins on component boards.
 - Do not touch circuit components inside the equipment.
 - If available, use a static-safe workstation.
 - When not in use, store the equipment in appropriate static-safe packaging.
-

Removal and Insertion Under Power

WARNING

When you insert or remove the module while backplane power is on, an electrical arc can occur. This could cause an explosion in hazardous location installations.

Be sure that power is removed or the area is nonhazardous before proceeding. Repeated electrical arcing causes excessive wear to contacts on both the module and its mating connector. Worn contacts may create electrical resistance that can affect module operation.

European Hazardous Location Approval

If you install the module in a European Zone 2 location, consider:

European Zone 2 Certification (The following applies when the product bears the EEx Marking)

This equipment is intended for use in potentially explosive atmospheres as defined by European Union Directive 94/9/EC.

The LCIE (Laboratoire Central des Industries Electriques) certifies that this equipment has been found to comply with the Essential Health and Safety Requirements relating to the design and construction of Category 3 equipment intended for use in potentially explosive atmospheres, given in Annex II to this Directive. The examination and test results are recorded in confidential report No. 28 682 010.

Compliance with the Essential Health and Safety Requirements has been assured by compliance with EN 50021.



IMPORTANT

When using this product, also consider the following:

- This equipment is not resistant to sunlight or other sources of UV radiation.
 - The secondary of a current transformer shall not be open-circuited when applied in Class I, Zone 2 environments.
 - Equipment of lesser Enclosure Type Rating must be installed in an enclosure providing at least IP54 protection when applied in Class I, Zone 2 environments.
 - This equipment shall be used within its specified ratings defined by Allen-Bradley.
 - Provision shall be made to prevent the rated voltage from being exceeded by transient disturbances of more than 40% when applied in Class I, Zone 2 environments.
-

North American Hazardous Location Approval

The following information applies when operating this equipment in hazardous locations:	Informations sur l'utilisation de cet équipement en environnements dangereux:
<p>Products marked "CL I, DIV 2, GP A, B, C, D" are suitable for use in Class I Division 2 Groups A, B, C, D, Hazardous Locations and nonhazardous locations only. Each product is supplied with markings on the rating nameplate indicating the hazardous location temperature code. When combining products within a system, the most adverse temperature code (lowest "T" number) may be used to help determine the overall temperature code of the system. Combinations of equipment in your system are subject to investigation by the local Authority Having Jurisdiction at the time of installation.</p>	<p>Les produits marqués "CL I, DIV 2, GP A, B, C, D" ne conviennent qu'à une utilisation en environnements de Classe I Division 2 Groupes A, B, C, D dangereux et non dangereux. Chaque produit est livré avec des marquages sur sa plaque d'identification qui indiquent le code de température pour les environnements dangereux. Lorsque plusieurs produits sont combinés dans un système, le code de température le plus défavorable (code de température le plus faible) peut être utilisé pour déterminer le code de température global du système. Les combinaisons d'équipements dans le système sont sujettes à inspection par les autorités locales qualifiées au moment de l'installation.</p>

The following information applies when operating this equipment in hazardous locations:		Informations sur l'utilisation de cet équipement en environnements dangereux:	
<p>WARNING</p> 	<p>EXPLOSION HAZARD</p> <ul style="list-style-type: none"> • Do not disconnect equipment unless power has been removed or the area is known to be nonhazardous. • Do not disconnect connections to this equipment unless power has been removed or the area is known to be nonhazardous. Secure any external connections that mate to this equipment by using screws, sliding latches, threaded connectors, or other means provided with this product. • Substitution of components may impair suitability for Class I, Division 2. • If this product contains batteries, they must only be changed in an area known to be nonhazardous. 	<p>AVERTISSEMENT</p> 	<p>RISQUE D'EXPLOSION</p> <ul style="list-style-type: none"> • Couper le courant ou s'assurer que l'environnement est classé non dangereux avant de débrancher l'équipement. • Couper le courant ou s'assurer que l'environnement est classé non dangereux avant de débrancher les connecteurs. Fixer tous les connecteurs externes reliés à cet équipement à l'aide de vis, loquets coulissants, connecteurs filetés ou autres moyens fournis avec ce produit. • La substitution de composants peut rendre cet équipement inadapté à une utilisation en environnement de Classe I, Division 2. • S'assurer que l'environnement est classé non dangereux avant de changer les piles.

Identify Module Components

Use the following figure to identify the external features of the module.

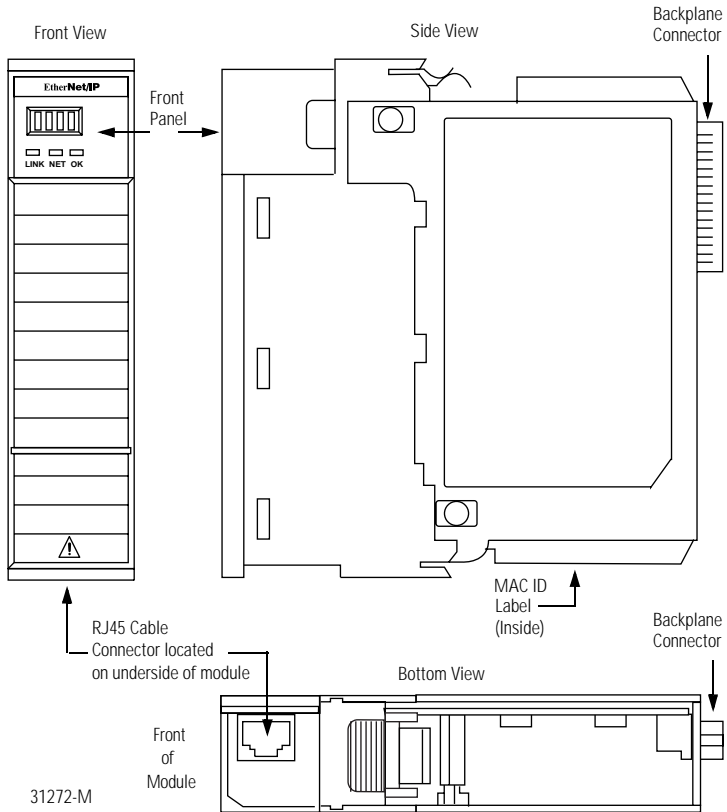

Prepare the Chassis for Module Installation

Before you install the module, you must install and connect a ControlLogix chassis and power supply.

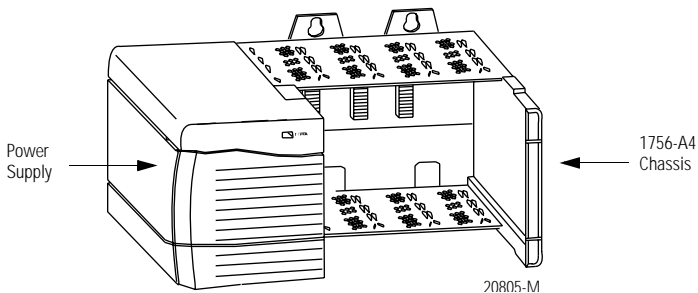

For information on installing these products, refer to the publications listed below.

Chassis Type	Chassis Installation	Power Supply	Power Supply Installation
Series B: 1756-A4, -A7, -A10, -A13	Pub. No. 1756-IN080	1756-PA72/B	Pub. No. 1756-5.67
		1756-PB72/B	
		1756-PA75/A	Pub. No. 1756-5.78
		1756-PB75/A	

Determine Module Slot Location

You can install the module in any slot in the ControlLogix chassis. You can also install multiple 1756-ENBT modules in the same chassis. The figure below shows chassis slot numbering in a 4-slot chassis. Slot 0 is the first slot and is always the leftmost slot in the rack (the first slot to the right of the power supply).

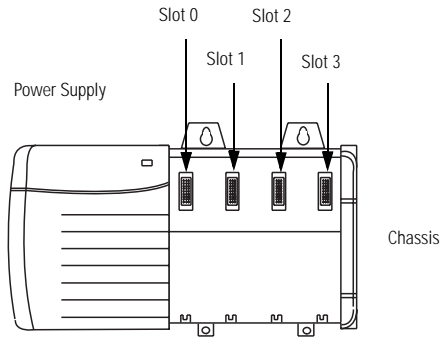

Install the Module in the Chassis

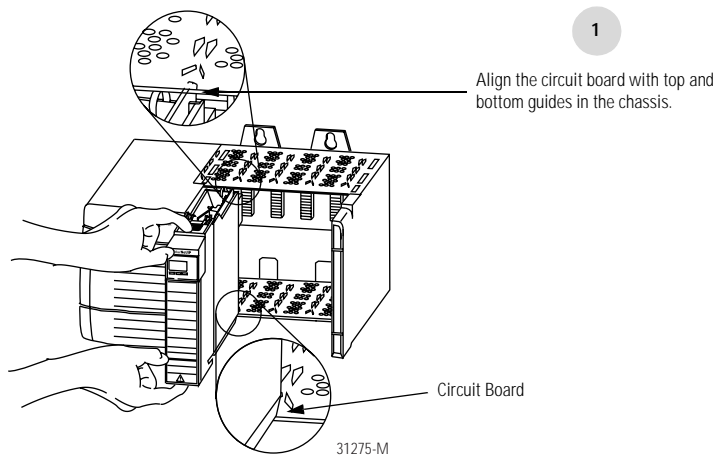

2

Slide the module into the chassis. Make sure the module backplane connector properly connects to the chassis backplane.

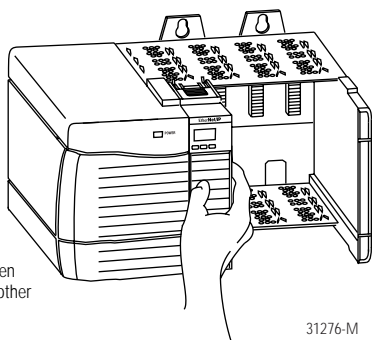

Remove or Replace the Module (when applicable)

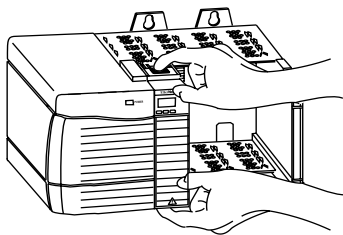

31277-M

1

Push on upper and lower module tabs to disengage them.

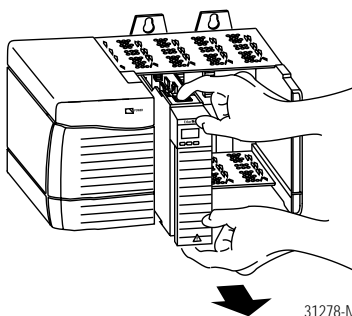

31278-M

2

Slide module out of chassis.

IMPORTANT

If you are replacing an existing module with an identical one, and you want to resume identical system operation, you must install the new module in the same slot.

Install or Remove the Module Under Power

This module is designed to be installed or removed while chassis power is applied.

WARNING



When you insert or remove a module while backplane power is on, an electrical arc may occur. An electrical arc can cause personal injury or property damage by:

- sending an erroneous signal to your system's field device causing unintended machine motion or loss of process control
- causing an explosion in a hazardous environment

Repeated electrical arcing causes excessive wear to contacts on both the module and its mating connector. Worn contacts may create electrical resistance that can affect module operation.

Wire the Ethernet Connector

Use an RJ45 connector to connect to the EtherNet/IP network. Wire the connector according to the following illustration:

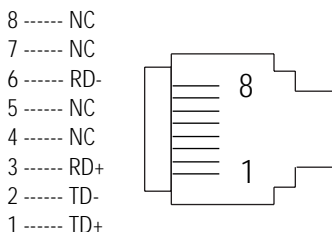

RJ 45

For detailed EtherNet/IP connection information, see the EtherNet/IP Media Planning and Installation Guide, publication number ENET-IN001.

Connect the Module to the EtherNet/IP Network

WARNING

If you connect or disconnect the Ethernet cable with power applied to this module or any device on the network, an electrical arc can occur. This could cause an explosion in hazardous location installations. Be sure that power is removed or the area is nonhazardous before proceeding.

Attach the RJ45 connector to the Ethernet port on the bottom of the module as shown below:

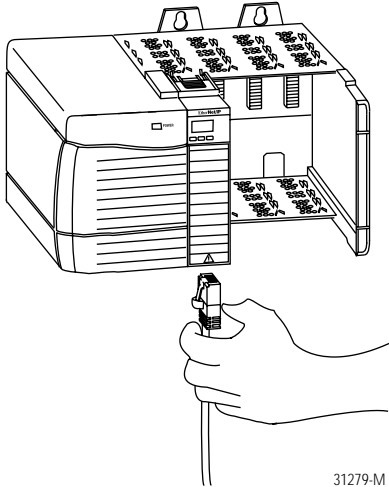

IMPORTANT

We recommend connecting the module to the network via a 100MB Ethernet switch, which will reduce collisions and lost packets and increase network bandwidth. For detailed EtherNet/IP connection information, see the following publications:

- EtherNet/IP Performance and Application Guide, publication ENET-AP001
- EtherNet/IP Media Planning and Installation Guide, publication ENET-IN001

Apply Chassis Power

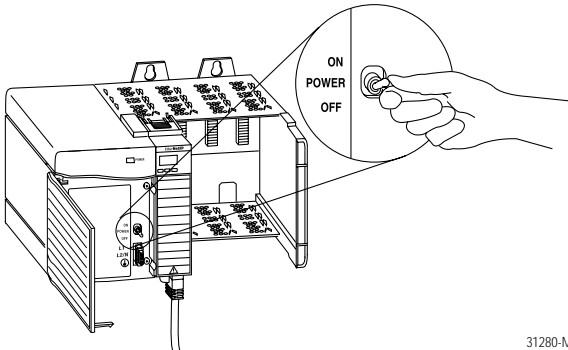

31280-M

Check Power Supply and Module Status

Check the LED indicators and alphanumeric display to determine if the power supply and module are operating properly.

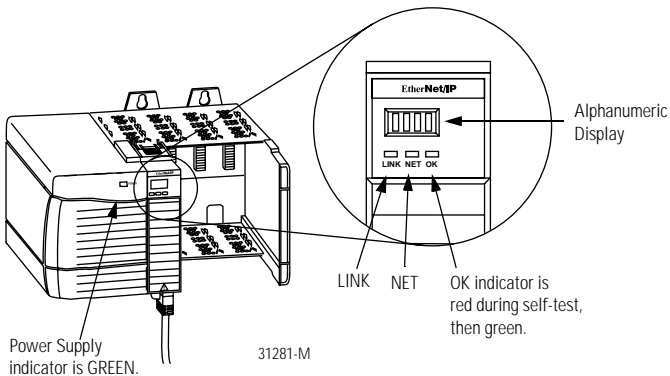

31281-M

The alphanumeric display should cycle through the following states: “TEST - PASS - OK - REV x.x,” where “x.x” is the module’s firmware revision. The display then alternates between “OK” and the module’s EtherNet/IP address.

Troubleshoot the Module

If the alphanumeric display and LED indicators do not sequence through the expected states refer to the following troubleshooting tables. The three bi-color (red/green) LED status indicators on the 1756-ENBT module provide diagnostic information about the module and its connections to the network.

NET (Network) Status Indicator

The Network Status LED provides the following information:

State	Status	Description
Off	Not Powered, No IP Address	Module is not powered, or does not have an IP address. <ul style="list-style-type: none"> • Verify there is chassis power and the module is completely inserted into the chassis and backplane. • Make sure the module has been configured.
Flashing Green	No Connections	Module has obtained an IP address, but has no established connections.
Green	CIP Connections	Module has an IP address and at least one established connection.
Flashing Red	Connection Timeout	One or more of the connections in which the module is the target has timed out.
Red	Duplicate IP Address	Module has detected that its IP address is already in use. Assign a unique IP address to the module.

Link Status Indicator

The Link Status LED provides the following information:

State	Status	Description
Off	No data transmission	Module is not ready to communicate.
Green	Ready	Module is ready to communicate.
Flashing Green	Data transmission in progress	Module is communicating over the network.

OK Status Indicator

The OK Status LED provides the following module information:

State	Status	Description
Off	No Power	Module does not have 24V DC power. Verify there is chassis power and the module is completely inserted into chassis and backplane.
Flashing Green	Standby	Module is not configured.
Green	Operational	Module is operating correctly.
Flashing Red	Minor Fault	A recoverable fault has been detected. This could be caused by an error in the configuration.
Red	Major Fault	An unrecoverable fault has been detected. Recycle power to the module. If this does not clear the fault, replace the module.
Flashing Red and Green	Self Test	Module performing power-up self-test.

Where to Find Information on Configuring the Module

To configure your module, refer to the configuration chapter of your **EtherNet/IP Modules User Manual**, publication number ENET-UM001, available online at www.rockwellautomation.com/literature.

Specifications

Module Location	Any slot in the ControlLogix chassis
Backplane Current (mA) at 5V.1V dc	700mA
Backplane Current (mA) at 24V	3mA
Isolation Voltage, Continuous	30V Tested to 707V dc for 60 seconds
Power Dissipation, Max.	3.65W
Conductors Wire Size Category	802.3 compliant - shielded or unshielded twisted pair 2 ¹
Ethernet Connector	RJ45 Cat. 5
User Manual	ENET-UM001
Environmental Conditions	
Operating Temperature	IEC 60068-2-1 (Test Ad, Operating Cold), IEC 60068-2-2 (Test Bd, Operating Dry Heat), IEC 60068-2-14 (Test Nb, Operating Thermal Shock): 0 to 60°C (32 to 140°F)
Storage Temperature	IEC 60068-2-1 (Test Ab, Un-packaged Non-operating Cold), IEC 60068-2-2 (Test Bb, Un-packaged Non-operating Dry Heat), IEC 60068-2-14 (Test Na, Un-packaged Non-operating Thermal Shock): -40 to 85°C (-40 to 185°F)
Relative Humidity	IEC 60068-2-30 (Test Db, Un-packaged Non-operating Damp Heat): 5 to 95% non-condensing
Vibration	IEC60068-2-6 (Test Fc, Operating): 2g @ 10-500Hz
Shock, Operating	IEC60068-2-27 (Test Ea, Unpackaged shock): 30g

Shock, Non-operating	IEC60068-2-27 (Test Ea, Unpackaged shock): 50g
Emissions	CISPR 11: Group 1, Class A
ESD Immunity	IEC 61000-4-2: 6kV contact discharges 8kV air discharges
Radiated RF Immunity	IEC 61000-4-3: 10V/m with 1kHz sine-wave 80%AM from 30MHz to 2000MHz 10V/m with 200Hz 50% Pulse 100%AM at 900MHz 10V/m with 200Hz 50% Pulse 100%AM at 1890MHz
EFT/B Immunity	IEC 61000-4-4: ±2kV at 5kHz on communications ports
Surge Transient Immunity	IEC 61000-4-5: ±2kV line-earth(CM) on communications ports
Conducted RF Immunity	IEC 61000-4-6: 10Vrms with 1kHz sine-wave 80%AM from 150kHz to 80MHz
Enclosure Type Rating	None (open-style)

<p>Certifications² (when product is marked)</p>	<p>UL UL Listed Industrial Control Equipment</p> <p>CSA CSA Certified Process Control Equipment</p> <p>CSA CSA Certified Process Control Equipment for Class I, Division 2 Group A,B,C,D Hazardous Locations</p> <p>FM FM Approved Equipment for use in Class I Division 2 Group A,B,C,D Hazardous Locations</p> <p>CE European Union 89/336/EEC EMC Directive, compliant with: EN 50082-2: Industrial Immunity EN 61326; Meas./Control/Lab., Industrial Requirements EN 61000-6-2: Industrial Immunity EN 61000-6-4: Industrial Emissions</p> <p>C-Tick Australian Radiocommunications Act, compliant with: AS/NZS CISPR 11; Industrial Emissions</p> <p>EEx European Union 94/9/EEC ATEX Directive, compliant with: EN 50021; Potentially Explosive Atmospheres, Protection "n" (Zone 2)</p> <p>EtherNet/IP ODVA conformance tested to EtherNet/IP specifications</p>
--	---

¹ Use this Conductor Category information for planning conductor routing. Refer to publication 1770-4.1, "Industrial Automation Wiring and Grounding Guidelines".

² See the Product Certification link at www.ab.com for Declarations of Conformity, Certificates, and other certification details.

Allen-Bradley and ControlLogix are trademarks of Rockwell Automation.

Ethernet is a trademark of Digital Equipment Corporation, Intel, and Xerox Corporation.

www.rockwellautomation.com

Corporate Headquarters

Rockwell Automation, 777 East Wisconsin Avenue, Suite 1400, Milwaukee, WI, 53202-5302 USA, Tel: (1) 414.212.5200, Fax: (1) 414.212.5201

Headquarters for Allen-Bradley Products, Rockwell Software Products and Global Manufacturing Solutions

Americas: Rockwell Automation, 1201 South Second Street, Milwaukee, WI 53204-2496 USA, Tel: (1) 414.382.2000, Fax: (1) 414.382.4444
Europe: Rockwell Automation SA/NV, Vorstlaan/Boulevard du Souverain 36-BP 3A/B, 1170 Brussels, Belgium, Tel: (32) 2 663 0600, Fax: (32) 2 663 0640
Asia Pacific: Rockwell Automation, 27/F Citicorp Centre, 18 Whitfield Road, Causeway Bay, Hong Kong, Tel: (852) 2887 4788, Fax: (852) 2508 1846

Headquarters for Dodge and Reliance Electric Products

Americas: Rockwell Automation, 6040 Ponders Court, Greenville, SC 29615-4617 USA, Tel: (1) 864.297.4800, Fax: (1) 864.281.2433
Europe: Rockwell Automation, Brühlstraße 22, D-74834 Elztal-Dallau, Germany, Tel: (49) 6261 9410, Fax: (49) 6261 17741
Asia Pacific: Rockwell Automation, 55 Newton Road, #11-01/02 Revenue House, Singapore 307987, Tel: (65) 351 6723, Fax: (65) 355 1733

Publication 1756-IN019C-EN-P - November 2004

PN 957944-26

Supersedes Publication 1756-IN019B-EN-P - August 2001

Copyright © 2004 Rockwell Automation, Inc. All rights reserved. Printed in the U.S.A.