

32-bit High-Voltage Digital Input and/or Output Board with P2 I/O and Built-in-Test

- 32 bits of high-voltage outputs
 - High-voltage outputs
 - High-current sink (600 mA)
 - High breakdown voltage (60 V minimum)
 - Output clamp diodes
 - Overcurrent protected (1 A) thermal limit protection
 - UDN2549B incandescent or inductive load driver (no external warming or current limiting resistors required)
- 32 bits of high-voltage inputs
 - Each group of 8 inputs are jumper-selectable to monitor: contact closure, voltage source, current sinking, and differential signals
 - Open circuit provides logic *zero* or (jumper-selectable) logic *one*
 - Input filter option
 - User-selectable input voltage thresholds (1.25 to 60 V)
- P2 I/O connection (no front panel connectors)
- Built-in-Test (off-line and real-time support)
- 100 percent testing of all active components (including output drivers)
- Front panel with fail LED

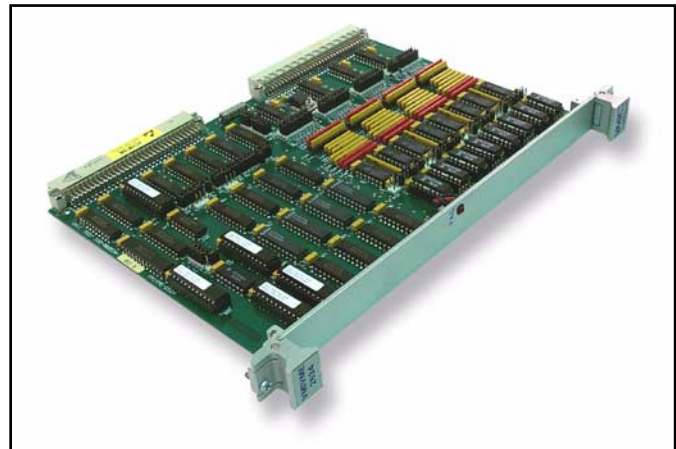

FUNCTIONAL CHARACTERISTICS

Compliance: This product complies with the VMEbus specification Rev. C. 1 with the following mnemonics:

A16:D32, D16, D08 (EO): 29, 2D: Slave
6U form factor

Address Modifier Codes: Jumper-selectable for short supervisory or short nonprivileged I/O access. Factory configured for short supervisory I/O access.

Addressing Scheme: Four ports individually addressable on 8-, 16-, or 32-bit boundaries. The separate board address decoder for the Control and Status Register (CSR) and Board ID Register allows addresses for hardware control to be grouped for improved software efficiency.

Data Transfer: Supports 8-, 16-, or 32-bit data transfers

OUTPUT SPECIFICATION SUMMARY

Output Organization: Four ports, eight bits wide. Addressable to any address within short supervisory or short nonprivileged I/O map.

Output Features: The high-current driver (600 mA sink) outputs are designed to drive incandescent lamps and inductive loads without external current limiting or warming resistors. Due to cold filament inrush currents, it is recommended that only one lamp be driven by the output driver. However, if more than one bulb must be driven by a single wire, then another driver may be connected in parallel. If more than one bulb must be driven by a single output, it is recommended the VMIVME-2131 (current source/sink) or the VMIVME-2130 (current source only) be used.

Ordering Options							
October 28, 1994 800-002534-000 B	A	B	C	-	D	E	F
VMIVME-2534	-			-			
<p>A = Data Polarity ***</p> <p>0 = Positive True Outputs 1 = Negative True Outputs 4 = Negative True Outputs (2532A Program Compatible) 9 = Reserved</p> <p>B = Pull-Up Resistor Options (0.12 W) **</p> <p>0 = 270 (5.8 V Maximum) 1 = 560 (8 V Maximum) 2 = 1.5 k (13.7 V Maximum) 3 = 3.3 k (20 V Maximum) 4 = 6.8 k (29 V Maximum) 5 = 27 k (58 V Maximum)</p> <p>C = Input Filter/Terminator Options</p> <p>0 = With Input Filter/Terminator* 1 = Without Input Filter/Terminator 2 = 2 μs Filter 3 = 10 μs Filter 4 = 1 ms Filter 5 = 5 ms Filter 6 = 10 ms Filter</p>							
Notes							
<p>* The input filter/terminator circuit can be jumper-selected to provide a series RC terminator (as shown in Figure 3), or as an input filter (with a time constant of 0.14 ms). This product can be manufactured with filter options as shown. Contact the factory for other time constants. Use this option for RS-422/RS-485-compatible receivers.</p> <p>** The pull-up and pull-down (33 K) SIP resistors are installed in sockets and can be interchanged by the user.</p> <p>*** Option 4 to be used in UIOCs® and IIOC instead of Option 1.</p>							
Connector Data							
PC Board Connector Is				Panduit No. 100-096-033			
VMEbus Standard P2							
<p>For Ordering Information, Call: 1-800-322-3616 or 1-256-880-0444 • FAX (256) 882-0859 E-mail: info@vmic.com Web Address: www.vmic.com Copyright © October 1988 by VMIC Specifications subject to change without notice.</p>							

The output drivers also feature: thermal current shutdown protection, high breakdown voltage (60 V), and output clamp diodes for inductive flyback protection. Details concerning the output driver design and description are shown on page 3.

Pull-up resistors for TTL or electronic switch outputs are optional.

Output Sustaining Voltage: 35 V minimum

Overcurrent Protected Output Voltage: 25 V

Output Saturation Voltage: See Tables 3 and 4

Output Data Option: Positive true or negative true options

INPUT SPECIFICATION SUMMARY

Single-Ended Signal Input Characteristics: High input impedance (33 k Ω). Threshold accuracy of 1 percent over entire 60 V range (typical). Refer to Figure 4 for typical single-ended signal conditioning electronics.

Differential Signal Input Characteristics: Common-mode input voltage range: -30 to +60 V Input sensitivity of ± 100 mV over common-mode range of -7 to +12 V High input impedance (33 k Ω)

Signal Conditioning Input Filter Terminator Option: The board may be ordered with a variety of input signal conditioning filter circuits. For differential inputs, the circuit consists of a series resistor and capacitor connected across the signal input (see Figure 3); whereas, for single-ended inputs, the input circuit can be jumpered to provide an input debounce filter (see the Ordering Options).

Absolute Maximum Input Voltage: ± 60 V sustained

GENERAL SPECIFICATION SUMMARY

Number of I/O Ports: Four (8 bits per port)

Input/Output Control: Each port is individually selectable to be input or output via jumpers or under software control.

Built-in-Test Features: This board is designed with internal self-test logic. CMOS buffers connect the Output Data Registers (ODRs) directly to the input voltage comparators to generate comparator offsets that may be used as a *health test* during off-line operation. The VMIVME-2534 also supports real-time testing of output drivers and/or input voltage comparators for fault detection and isolation to the board/bit level.

Control and Status Register (CSR): One CSR is provided to control the front panel Fail LED and internal Built-in-Test features.

Fail LED: A front panel Fail LED is provided which can be turned ON and OFF under program control. This LED is illuminated at power on and system reset.

PHYSICAL/ENVIRONMENTAL

Temperature Range: 0 to 55 $^{\circ}\text{C}$, operating -20 to 85 $^{\circ}\text{C}$, storage

Relative Humidity Range: 20 to 80 percent, noncondensing

Cooling: Convection

Power Requirements: +5 V at 2.1 A maximum

APPLICATIONS —

- Relay drivers
- Lamp drivers
- Solenoid drivers
- Hammer drivers
- Stepper motor drivers
- Triac drivers
- LED drivers
- High-current, high-voltage drivers
- Fiber-optic LED drivers

POSITIVE/NEGATIVE TRUE ORDERING INFORMATION — This board may be ordered with positive or negative true output options. The data conversion (inversion) is determined by the selection of output data latches.

A positive true output option causes a VMEbus logical *one* to turn the corresponding output transistor ON, which supplies the user with zero volts.

The negative true output option causes a VMEbus logical *one* to turn the corresponding output transistor OFF, which supplies the user with an open circuit for open-collector output circuits, or with a high-voltage for electronic switch type output circuits.

INTELLIGENT I/O CONTROLLER (IIOC)

APPLICATION INFORMATION — VMIC's line of IIOCs support this product via its software compatibility with the VMIVME-2532A which limits the control to 32 bits of Digital Output or 32 bits of Digital Input. *

POWER DRIVER CIRCUIT DESCRIPTION AND APPLICATION

INCANDESCENT LAMP DRIVER — High incandescent lamp turn on/inrush current can destroy semiconductor lamp drivers and contributes to poor lamp reliability. However, individual lamps with steady state current ratings up to 700 mA can be driven with the UDN2549B without the need for warming or current limiting resistors.

When an incandescent lamp is initially turned ON, the cold lamp filament is at minimum resistance and would normally allow a 10 x to 12 x inrush current. With the UDN2549B, the high inrush current is sensed by an internal sense resistor. The load current is limited to approximately 1 A by the shunting transistor sensing the output current through the sense resistor. During this short transition period, the output driver is driven in a linear fashion. As the lamp warms up, the filament resistance increases to its maximum value. The output driver then goes into saturation and applies the full supply voltage to the lamp. However, inrush currents of 1 A or more will force the driver into foldback current limiting. If this is a problem, use warming or current limiting resistors in the lamp circuitry.

INDUCTIVE LOAD DRIVER — Bifilar (unipolar) stepper motors can be driven directly. The internal flyback diodes prevent damage to the output transistors by

suppressing the high-voltage spikes which are generated when turning OFF an inductive load.

FAULT CONDITIONS (Shorted Load or Stalled Motor) — Overcurrent protection has been designed into the UDN2549B and typically occurs at 1 A. It protects the device from output short circuits with supply voltages of up to 25 V. When the maximum driver output current is reached, the output stage is driven linearly. If the overall current condition continues, that output driver's thermal limiting will operate, limiting the driver's power dissipation and junction temperature. The outputs also include transient suppression diodes for use with inductive loads such as relays, solenoids, and stepper motors. In display applications, the diodes can be used for the lamp test function.

In the event of a shorted load, shorted winding, or stalled motor, the load current will attempt to increase. As described above, the drive current to the output stage is diverted (limiting the load current to about 1 A), causing the output stage to go linear. As the junction temperature of the output stage increases, the thermal limiting circuit will become operational, further decreasing the drive current. The load current (junction temperature) is then a function of ambient temperature, state of remaining drivers, supply voltage, and load resistance. If the fault condition is corrected, the output driver will return to its normal saturated condition.

TRADEMARKS

UIOC and the VMIC logo are registered trademarks of VMIC. Other registered trademarks are the property of their respective owners.

*Output drivers may be retrieved from sockets to improve reliability and eliminate output leakage current (100 mA at 60 V).

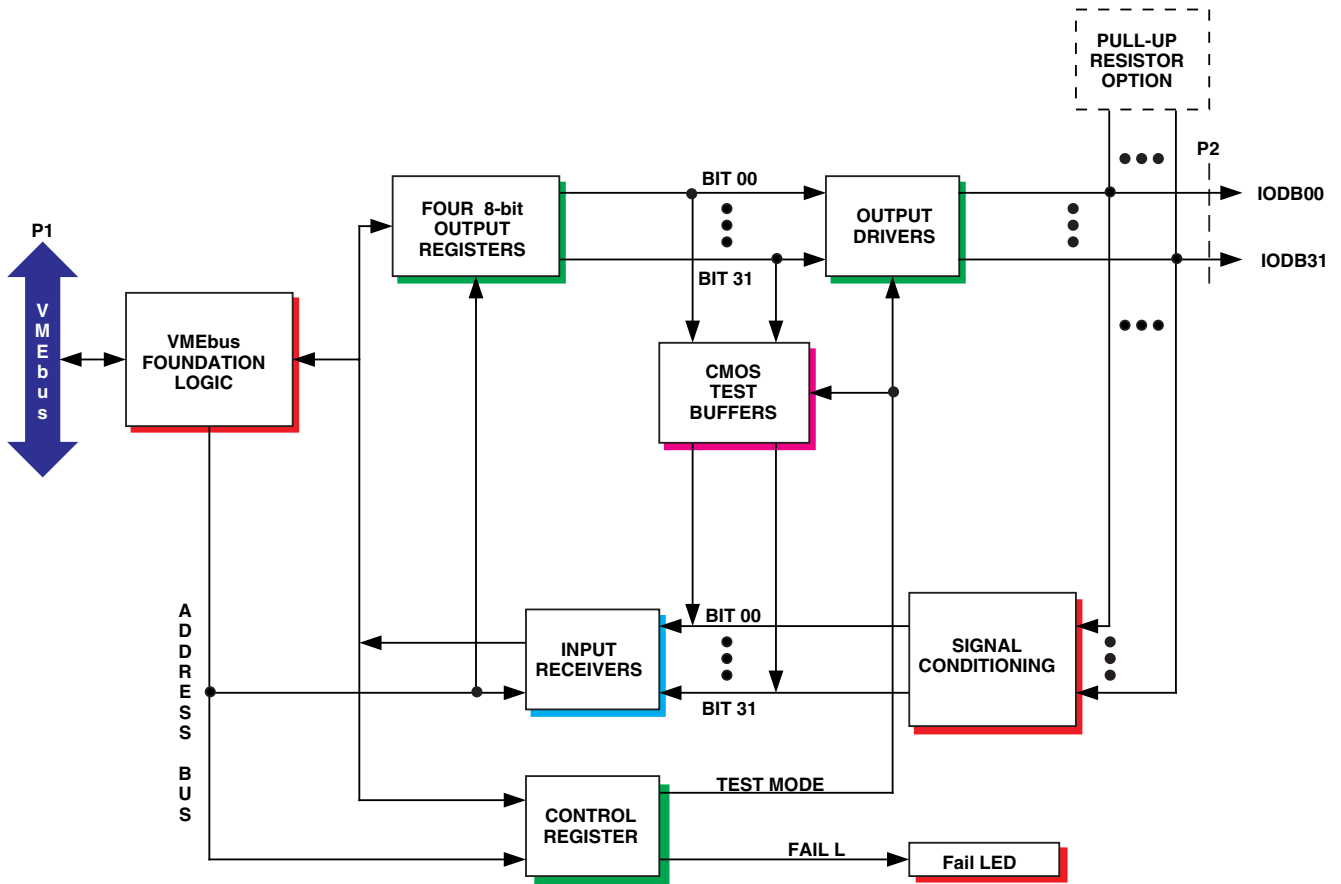

Figure 1. VMIVME-2534 Functional Block Diagram

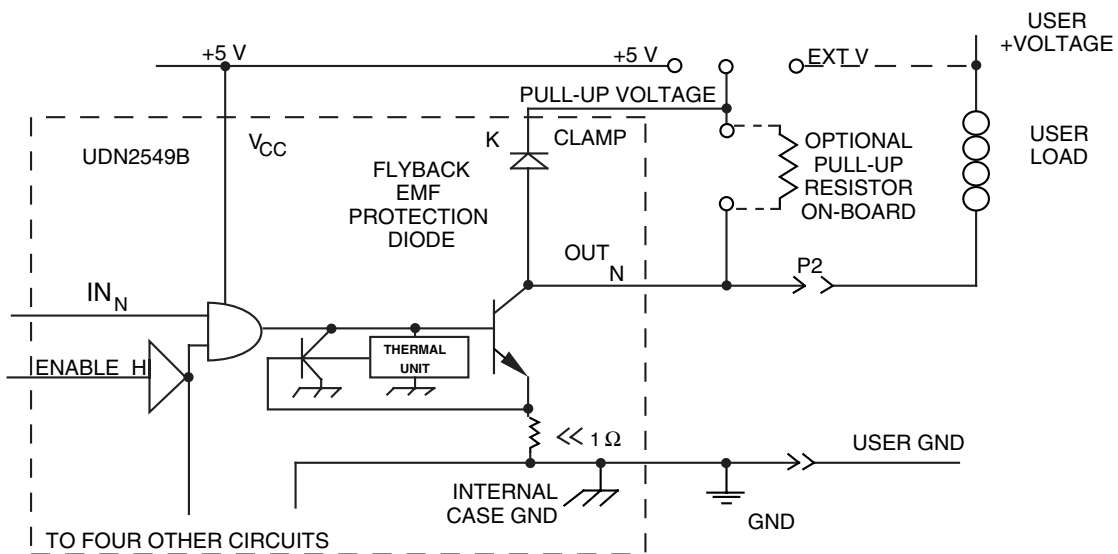
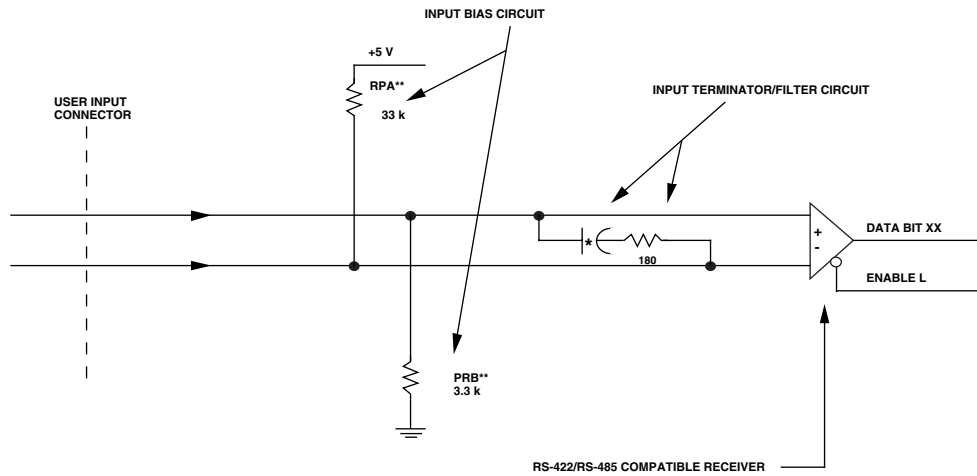
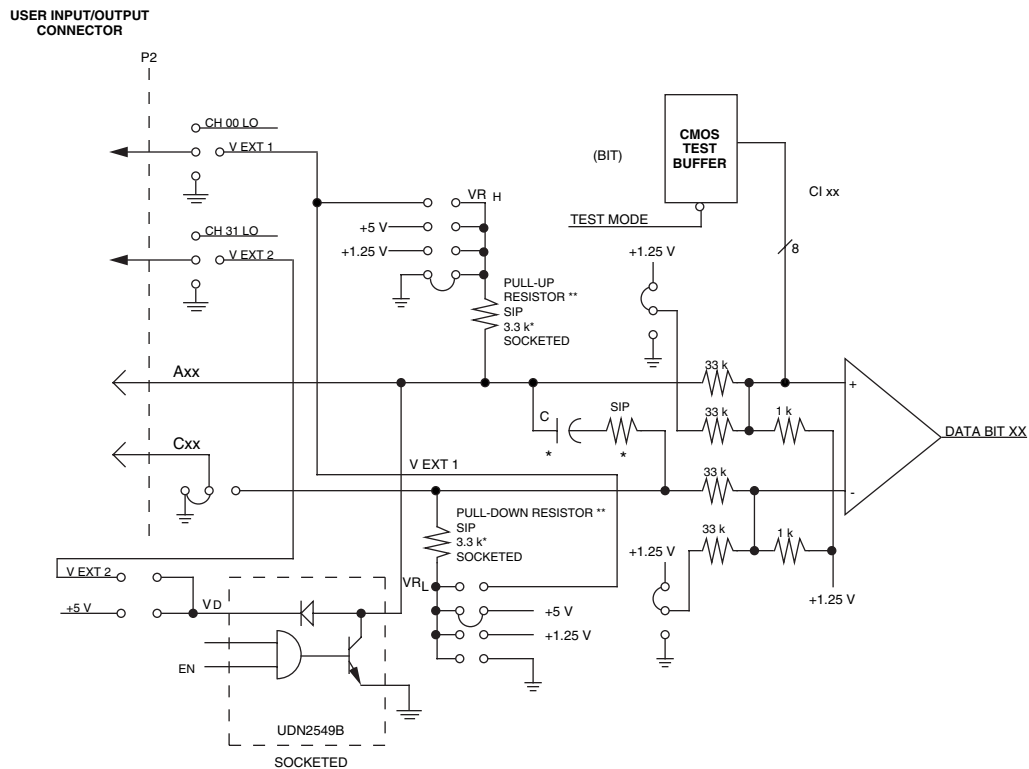

Figure 2. Output Driver Functional Diagram



*Manufacturing option.
 **PRA and RPB are socketed and may be swapped by the user to build other input configurations.

Figure 3. Differential Discrete Input Termination



*Manufacturing options.
 **These resistors are socketed and interchangeable.

Figure 4. Typical Input Signal Conditioning and Driver Circuitry

Output Electrical Specifications

**Table 1. Electronic Switch Configuration
(Open Collector with Pull-Up Resistor)**

OUTPUT VOLTAGE	PULL-UP RESISTOR	IOH MAX	IOL MAX	ABS MAX OUTPUT VOLTAGE
5 V	270.0 Ω	9.25 mA at 2.5 V	680 mA	5.8 V
12 V	1.5 k Ω	4.6 mA at 6 V	690 mA	13.7 V
24 V	6.8 k Ω	1.8 mA at 12 V	695 mA	29 V
48 V	27.0 k Ω	0.9 mA at 24 V	698 mA	58 V

**Table 2. TTL Configuration
(Open Collector with 560 Ω Pull-Up Resistor)**

PARAMETER	CONDITIONS	MIN	MAX	UNIT
VOH	IOH = 400 μ A	4.7		V
	IOH = 4.1 mA	2.7		V
VOL	IOL = 390 mA		0.7	V

**Table 3. Output Saturation Voltage for Open-Collector Option
(with 27 k Pull-Up Resistors Installed)**

I _{OUT}	V _{CE} MAX
100 mA	200 mV
400 mA	400 mV
700 mA	600 mV

Table 4. Pull-Up Resistor Option

PULL-UP RESISTOR OPTION	ABSOLUTE MAXIMUM INPUT VOLTAGE
270 Ω	5.8 V
560 Ω	8 V
1.5 kΩ	13.7 V
3.3 kΩ	20 V
6.8 kΩ	29 V
27 kΩ	58 V

Table 5. Threshold Voltages for Pull-Down Resistor = 3.3 kΩ
 $V_t = [(V - 1.25) (.91)] + 1.25$

VR_L	V_t
1.25 V	1.25 V
5 V	4.7 V
12 V	11 V
24 V	22 V
28 V	25.6 V
48 V	43.8 V
66 V	60.2 V

Table 6. Threshold Voltages for Pull-Down Resistor = 33 kΩ
 $V_t = [(V - 1.25) (.51)] + 1.25$

VR_L	V_t
1.25 V	1.25 V
5 V	3.2 V
12 V	6.7 V
24 V	12.9 V
28 V	14.8 V
48 V	25.1 V
66 V	34.3 V

APPLICATION AND CONFIGURATION GUIDES — The following Application and Configuration Guides are available from VMIC to assist the user in the selection, specification, and implementation of systems based on VMIC’s products.

Title

Document No.

Digital Input Board Application Guide	825-000000-000
Change-of-State Board Application Guide	825-000000-002
Digital I/O (with Built-in-Test) Product Line Description	825-000000-003
Synchro/Resolver (Built-in-Test) Subsystem Configuration Guide	825-000000-004
Analog I/O Products (with Built-in-Test) Configuration Guide	825-000000-005
Connector and I/O Cable Application Guide	825-000000-006