

THE POSITION MONITOR USING STRETCHED WIRE TECHNIQUE

T. Mimashi, S. Kuroda, H. Nakayama, K. Oide, R. Sugahara, N. Yamamoto

*National Laboratory for High Energy Physics (KEK),
Tsukuba, Ibaraki 305, Japan*

abstract

An alignment system using stretched wire method [1] is being developed as a component of the active alignment system for particle accelerator equipment, such as RF cavities and magnets. The RF voltage is supplied to the stretched wire and the monitor measures the change of capacitance between wire and pickup strip from induced charge. Present resolution, limited by the electronics noise, is about 5nm.

1. INTRODUCTION

An alignment system using stretched wire technique is developed for the precision alignment of the accelerator components. The system will be used in the final focus section of KEK future project such as B factory [2] and Japan Linear Collider (JLC) [3].

In addition to the beam based alignment, another independent alignment system is necessary for the continuous monitoring of relative position of quadrupole magnets. Since the beam size at the JLC final focus beam line is expected to be an order of a few nm to a few tens nm, the nano meter resolution alignment is required. The alignment system with stretched wires and pick up electrodes is developed for this purpose.

According to the ground motion measurement, an amplitude of seismic motion becomes less than 1 nm above 3 Hz.[4] Though other artificial vibration such as the vibration caused by cooling water is expected, the basic idea is "reduce high frequency vibration with visolator, and measure and cancel out only low frequency vibration with an actuator". The alignment system is designed to detect the vibration below 3 Hz.

2. PRINCIPLE

In this alignment system, the position of all monitors are determined relative to the stretched wire. Monitors with pickup electrodes are equipped closed to the stretched wire. A sinusoidal wave signal is supplied to the wire, and the induced charge on the two faced electrodes are amplified. By measuring the difference between the amplitude of signal from left and right electrodes, the monitor position can be measured relative to the wire.

In order to distinguish whether monitor or the wire support position moves, two stretched wires are necessary. Figure. 1 shows one simple example. The system consists of three monitors and two wires which are supported at four fixed points as shown in Fig. 1. Each monitor consists of two set of pickup electrodes which measure the vertical and horizontal position of two wires. Monitors and support points should move independently. Two wires are fixed at the same position on H1 and H4. Absolute position of H1 and H4 should be determined by another system, then both the position of fixed points H2, H3 and the position of pickup electrodes which will be mounted for example

on the quadrupole magnet, M1, M2 and M3 can be calculated from the output of signals from the 6 sets of pickup electrodes.

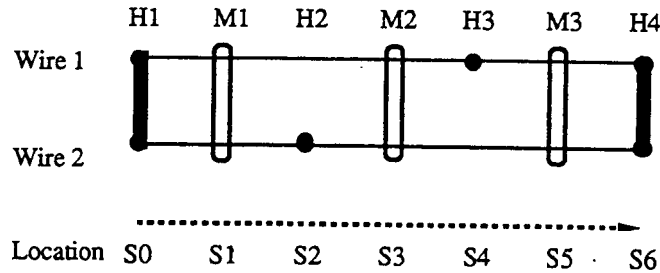

Fig. 1 An simple example of position measurement setup

3. SYSTEM DESIGN

A copper-beryllium, 0.2 mm diameter wire is used as a reference stretched wire. The wire is surrounded by the grounded aluminum tubes. The sinusoidal wave voltage signal 3 KHz, 8 V peak to peak, is supplied to the wire. In order to reduce the noise, preamplifiers are mounted directly on the 1.6mm thick, epoxy-graphite card containing four pickup electrodes. The both side of this card is clad with 0.2 mm of copper. This copper cladding is etched to provide the readout strip. The dimension of the strip electrode is 12 mm long along the wire, 1 mm wide and 0.2 mm thick. The change of the sinusoidal wave amplitude at the output of preamplifier corresponds to the 1 nm movement is calculated as a function of the displacement between the wire center and pickup electrode. (Fig. 2) The sensitivity increased rapidly at the short distance, so that the distance between the wire and each electrode is set to about 1.5 mm.

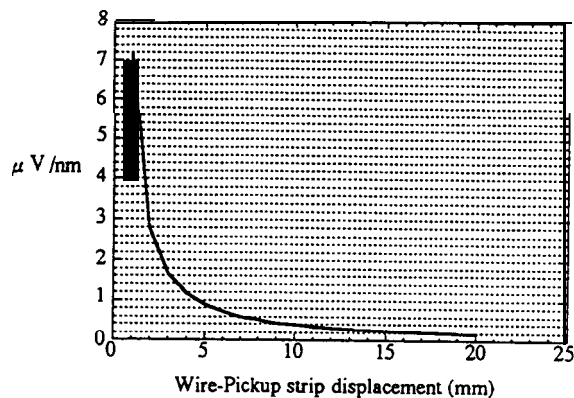

Fig. 2 The change of the sinusoidal wave amplitude at the output of preamplifier equivalent for the 1 nm movement as a function of wire-pickup strip displacement.

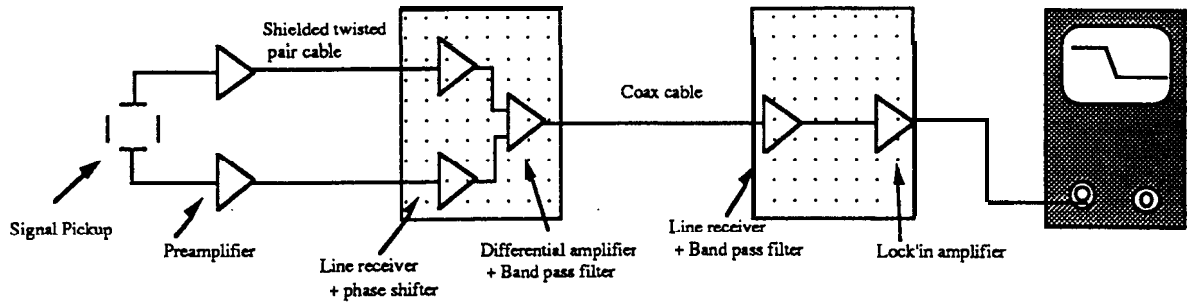

Fig. 3 A schematic of the front end electronics

4. ELECTRONICS

A simple schematic of the front end electronics for the stretched wire alignment system is shown in Fig. 3. The system consists of preamplifiers directory mounted on the pickup electrode card, a main amplifier circuit and a lock'in amplifier. A main amplifier module is connected to the pickup electrode-preamplifier card by 1 m long shielded twisted pair cables. A coax cable is used to send the signal from main amplifier to a lock'in amplifier.

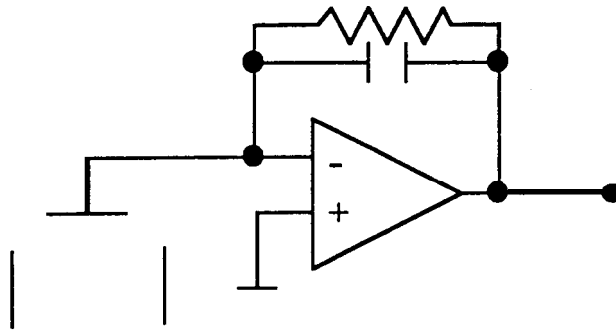

Fig. 4 Preamplifier circuit

4.1 Preamplifier

To get high gain and cancel out the coupling capacitance between two faced electrodes which loses the sensitivity a lot, a charge sensitive amplifier is chosen as a preamplifier. As shown in Fig 4, since the input of the operational amplifier is virtual ground, so that the voltage difference between two electrode is always 0. It means the effect of coupling capacitance between two faced electrode is canceled. The high impedance input, low noise operational amplifier (BB2604) is chosen.

4.2 Main Amplifier

A main amplifier circuit consists of line receivers, phase shifters, a differential amplifier with gain control trim resistor, bandpass filters and two inverting operational amplifiers. In order to cut ground loop noise, pulse transformers are used as line receivers. The phase shifters adjust the phase difference between signals from two faced electrodes. A differential amplifier amplifies the difference between two signals. A band pass filter is used to reduce the noise. And the signal is amplified that 1 nm movement corresponds to the a few mV amplitude change.

4.3 Lock'in Amplifier \

Each channel on the lock'in amplifier card consists of an operational amplifier receiver, two stages of band pass filter and phase detector. An analog signal passes through a linear amplifier whose gain is reversed by square wave reference signal controlling an analog switch. The output signal passes through a low-pass filter, RC. The response time is determined by this time constant. Totally, 1nm displacement corresponds 1.5 mV voltage change at the lock'in amplifier output.

5. PERFORMANCE

The schematic drawing of the bench test setup is shown in Fig. 5. A copper-beryllium wire, 0.2 mm diameter and 1 m long, is stretched on the visolator table [5]. The Piezo-electric actuators which can move the detector in the horizontal direction in a few nm step, are adopted as precision mover. The Piezo system was bought from PI-Polytec CO., LTD. The system consist of Piezo actuator and the inductive gage position sensor. Using the signal from the inductive gage position sensor, the extention of Piezo actuator is controlled. The accuracy of the inductive gage is a few nano meter.

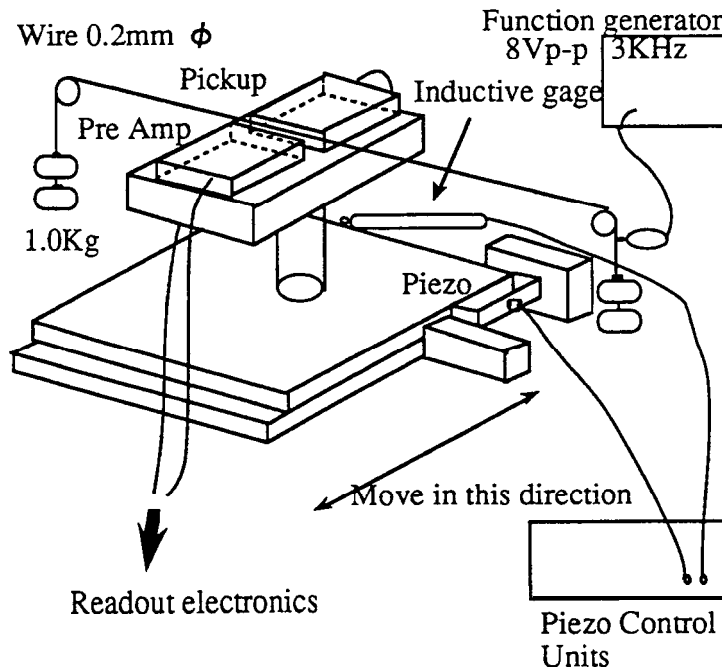

Fig. 5 The bench test setup for stretched wire alignment

Figure 6 shows resultant output signal of the lock'in amplifier circuit. The sensitivity is set to 1.5 mV/nm at the output voltage of the lock'in amplifier.

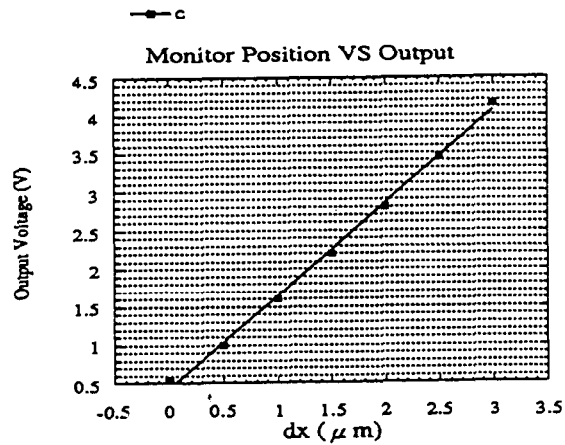

Fig. 6 Lock'in Amplifier output voltage as the function of displacement from reference point.

Figure 7 shows the output voltage change related to the monitor movement. Each step corresponds 50 nm movement of the monitor. The resolution of this alignment system is around 5 nm.

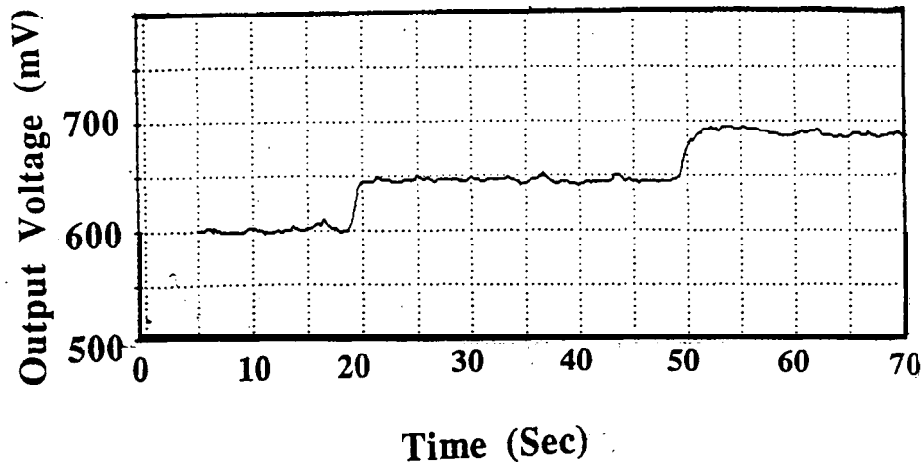

Fig. 7 The lock'in amplifier output voltage change when the monitor position is changed 50 nm step.

6. CONCLUSION

The stretched wire technique is being developed as a precision alignment methods. The electronics is designed that 1 nm displacement corresponds to 1.5 mV change at the lock'in amplifier output. The resolution is around 5 nm and the response time constant is set to 3 Hz.

We thank Dr. K.Taniguchi and Dr. Y.Fukushima for useful discussion about electronics circuit.

7. REFERENCES

- [1] Private communication to Prof. Vladimir E Balakin
- [2] S.Kurokawa et al., Accelerator design of the KEK B-factory, KEK Report 90-24, March 1991.
- [3] Y.Kimura et al., JLC-I, KJZK Report 92-16, December 1992.
- [4] Private communication to Prof. S. Takeda
- [5] Made by Herz Industry CO.,LTD.