

RARE D DECAYS (DIRTY AND CLEAN)

PONO: 5.75

KATIE: 3.1



BRENDAN CASEY, FNAL
CHARM 2007

OUTLINE

- FOCUS ON ANNIHILATION AND RADIATIVE DECAYS
 - HIGHLIGHT SENSITIVITY TO NEW PHYSICS
 - POINT OUT STRENGTHS AND WEAKNESSES OF DIFFERENT CHANNELS
- COMPARE TO SIMILAR TOPOLOGIES IN BEAUTY AND STRANGE SYSTEM
 - BETTER, WORSE, JUST DIFFERENT
- CONTRAST DIFFERENT TECHNIQUES USED IN DIFFERENT ENVIRONMENTS
- MOTIVATE FUTURE STUDIES
- TRY TO COVER ALMOST EVERYTHING IN LAST 5 YEARS BUT WILL PUT MOST FOCUS ON hl^+l^-

CHARGED ANNIHILATION

SENSITIVE TO TREE LEVEL
CHARGED CURRENT PHENOMENA
SM RATE CALCULABLE AND
EXPERIMENTALLY ACCESSIBLE

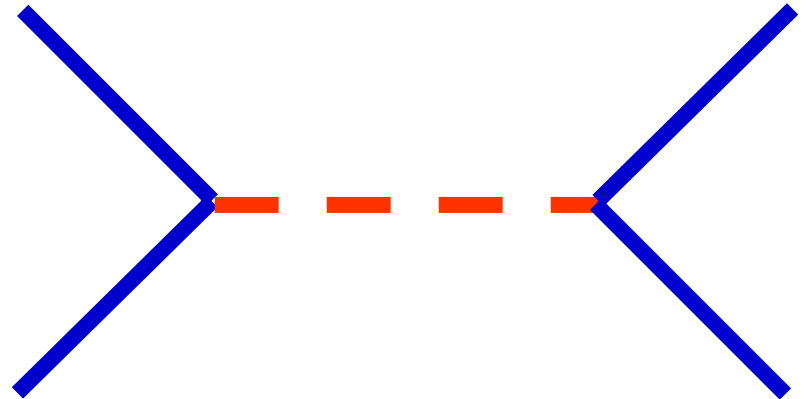

IF YOU KNOW THE DECAY CONSTANT AND CKM ELEMENT
YOU CAN LIMIT NEW PHENOMENA

IF YOU DON'T FIND ANY, YOU CAN MAKE PRECISE
MEASUREMENTS OF SM PARAMETERS

CHARGED ANNIHILATION: B VRS D

BEAUTY:

3RD GENERATION SO VERY SENSITIVE TO HIGH $\tan\beta$ SUSY/2HDM...

SENSITIVITY LIMITED BY ERRORS IN V_{ub} , f_B + *stats*

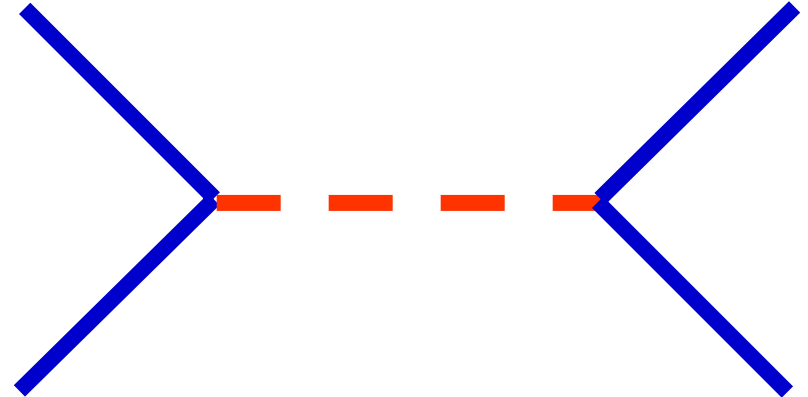

CHARM:

IN SOME CASES, NOT EVEN A RARE DECAY

NOT AS SENSITIVE TO 'FAVORED' NEW PHENOMENA MODELS

$\tau\nu$ AND $\mu\nu$ ACCESSIBLE

RATIOS PROVIDE CLEAN TEST OF MODELS THAT DON'T PRESERVE LEPTON UNIVERSALITY

RADIATIVE (AND NEUTRAL ANNIHILATION)

SENSITIVE TO TREE LEVEL
NEUTRAL CURRENT PHENOMENA
OR ANYTHING THAT FITS IN A
LOOP OR BOX

SM RATE SUPPRESSED IN ALL
CASES

SM CALCULATIONS RANGE FROM SIMPLE
TO IMPOSSIBLE.

COMPLETELY DIFFERENT FOR DIFFERENT
FLAVORS

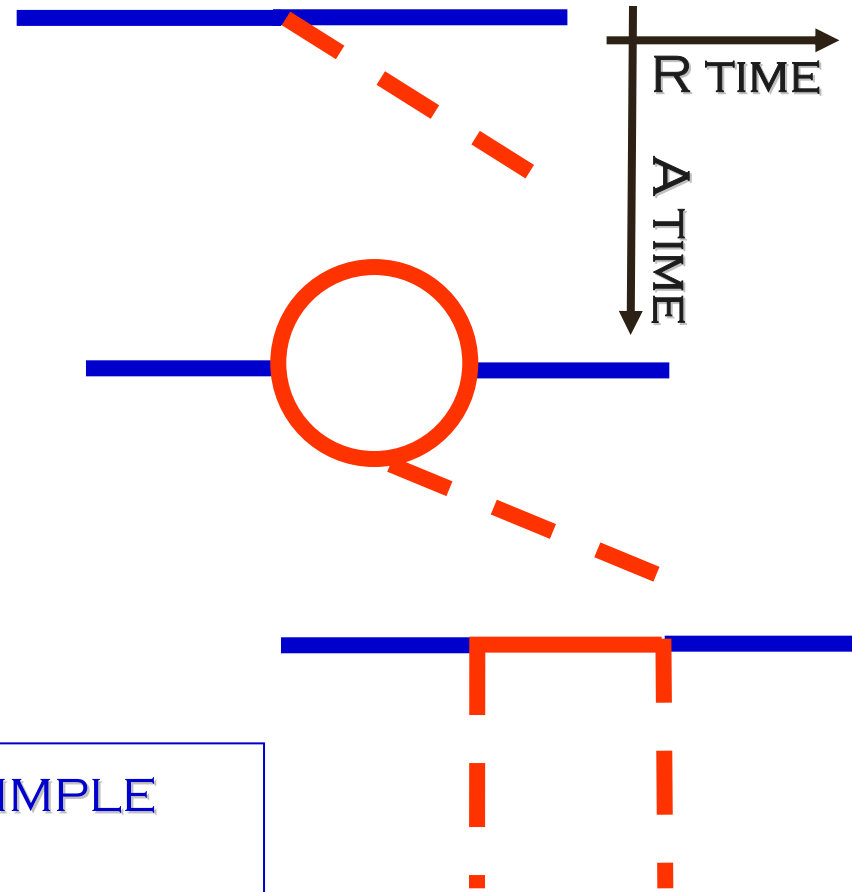

RAD AND NEUTRAL A: B, D, K

RADIATIVE:

- BEAUTY
 - PRECISION: THEORY AND EXP.
- STRANGE
 - PRECISION THEORY, EXP IN REACH
 - LOWER SN RATE = GRATER SENSITIVITY
- CHARM
 - THEORY = LONG DISTANCE
 - EXISTING MEASUREMENTS BEAUTIFUL BUT...

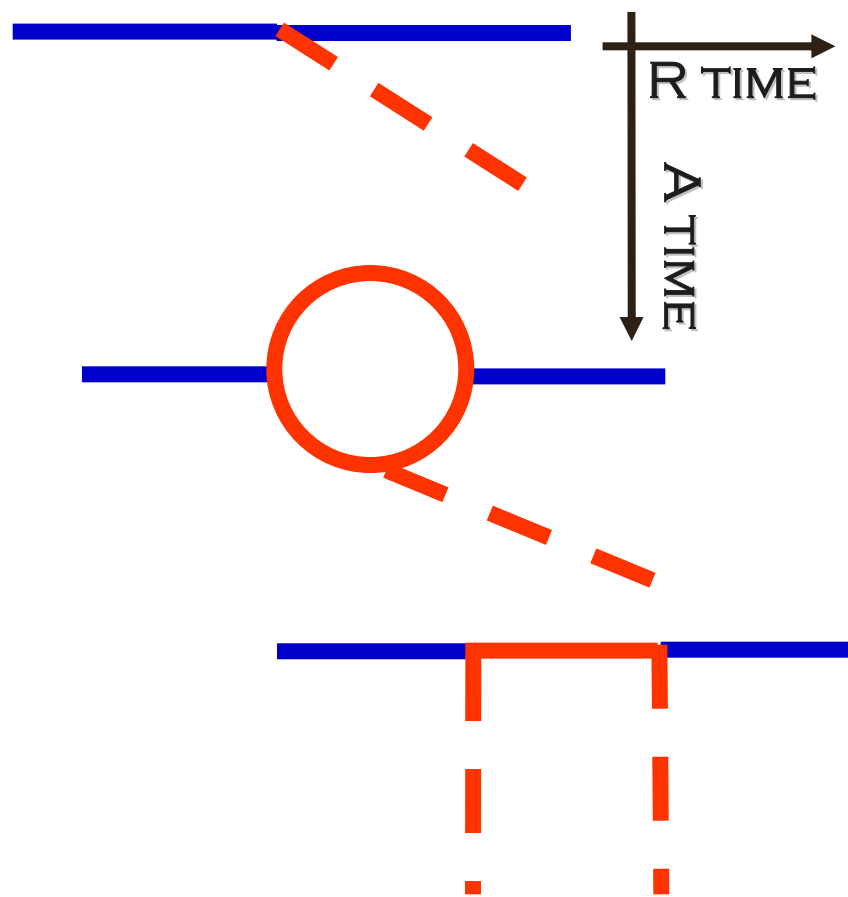

NEUTRAL ANNIHILATION:

ALMOST ALL NP PARAM SPACE LIMITED BY EXP MEASUREMENTS

BETTER LIMIT = BETTER PHYSICS (!)

WHAT IS THE SM TELLING US?

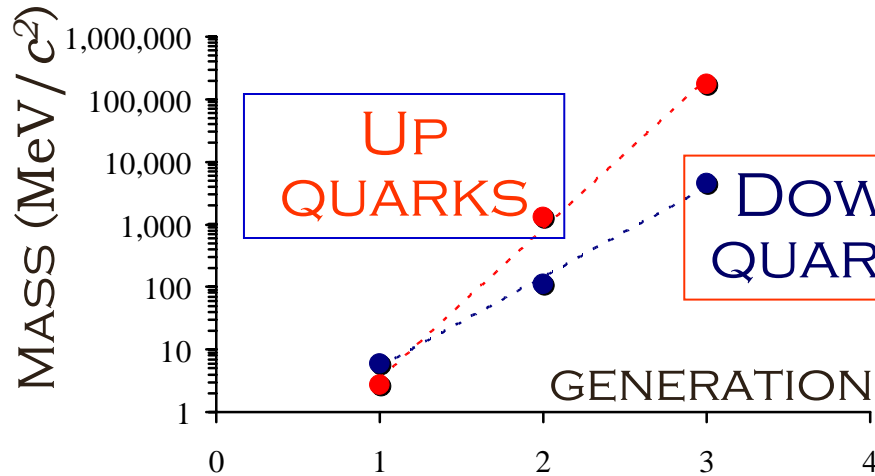

NEUTRAL LEPTONS

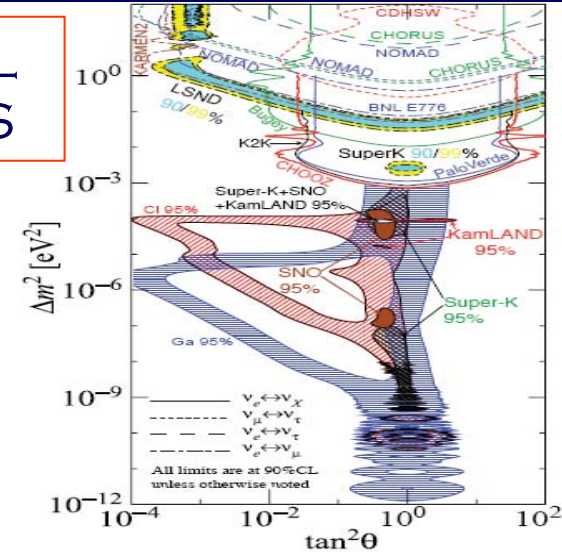

SM CARES ABOUT FLAVOR AND CHARGE.
HOW CAN BSM NOT?

$V_{CKM} =$ DOWN QUARKS

$$\begin{pmatrix} 0.97383^{+0.00024}_{-0.00023} & 0.2272^{+0.0010}_{-0.0010} & (3.96^{+0.09}_{-0.09}) \times 10^{-3} \\ 0.2271^{+0.0010}_{-0.0010} & 0.97296^{+0.00024}_{-0.00024} & (42.21^{+0.10}_{-0.80}) \times 10^{-3} \\ (8.14^{+0.32}_{-0.64}) \times 10^{-3} & (41.61^{+0.12}_{-0.78}) \times 10^{-3} & 0.999100^{+0.000034}_{-0.000004} \end{pmatrix}$$

UP QUARKS

$$V_{??} = \begin{pmatrix} 1 & 0 & 0 \\ 0 & 1 & 0 \\ 0 & 0 & 1 \end{pmatrix}$$

CHARGED LEPTONS

DIFFERENT ENVIRONMENTS

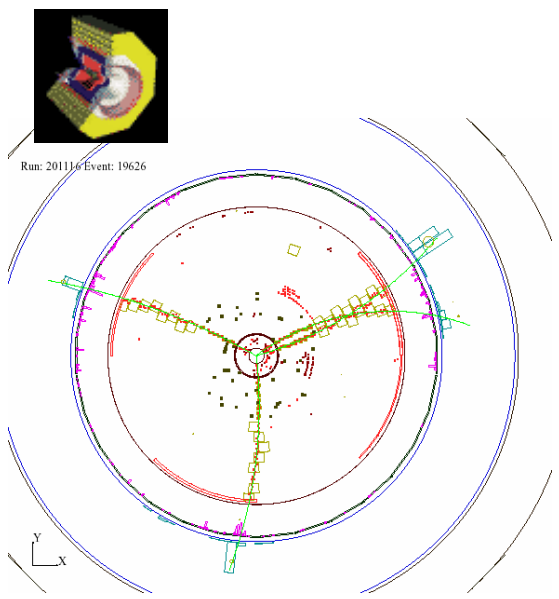

e^+e^- at threshold
Average
~5 tracks / evt

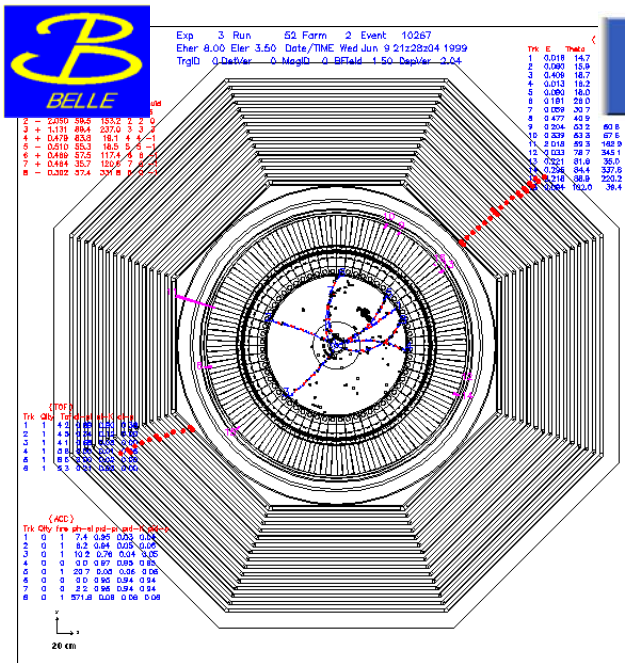

e^+e^- above threshold
Average
~10 tracks / evt

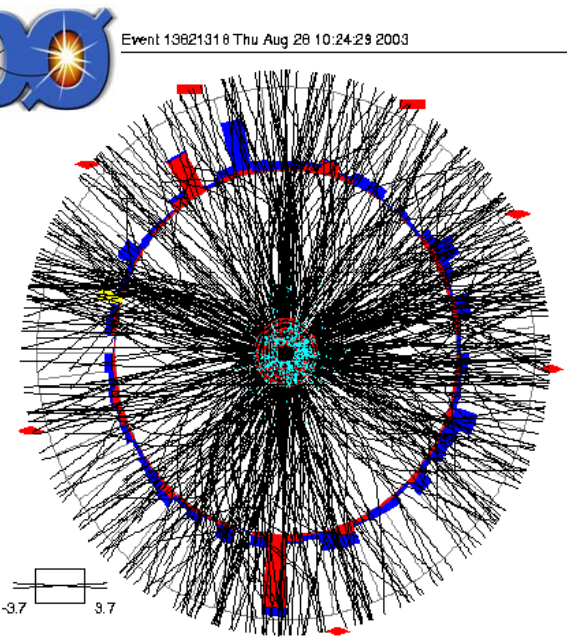

Tevatron
Average
~50 tracks / int.
Up to 10 int/evt

THRESHOLD: CLEO-c

- VERY CLEAN
- BEAM CONSTRAINTS
- DOUBLE TAGS
- NOW ENOUGH DATA FOR COMPETITIVE RARE DECAY STUDIES

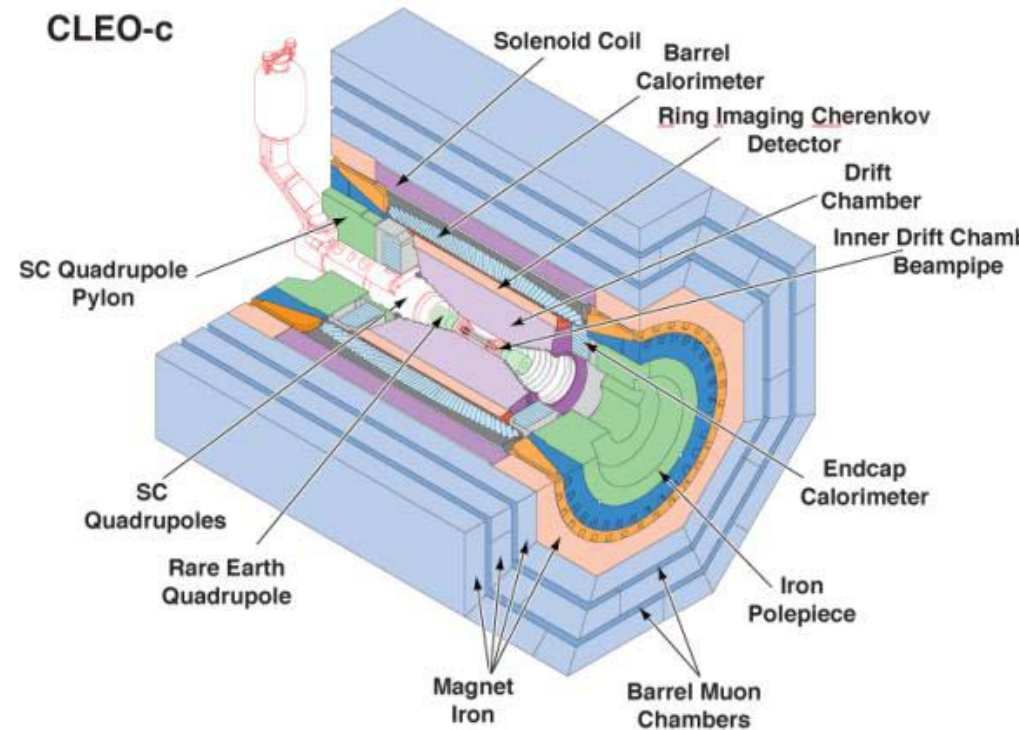

4S: BELLE & BABAR

- STILL PRETTY CLEAN
- EXCELLENT PID
- ALL CHARMED HADRON SPECIES ACCESSIBLE
- ENORMOUS DATA SETS AND STILL GROWING

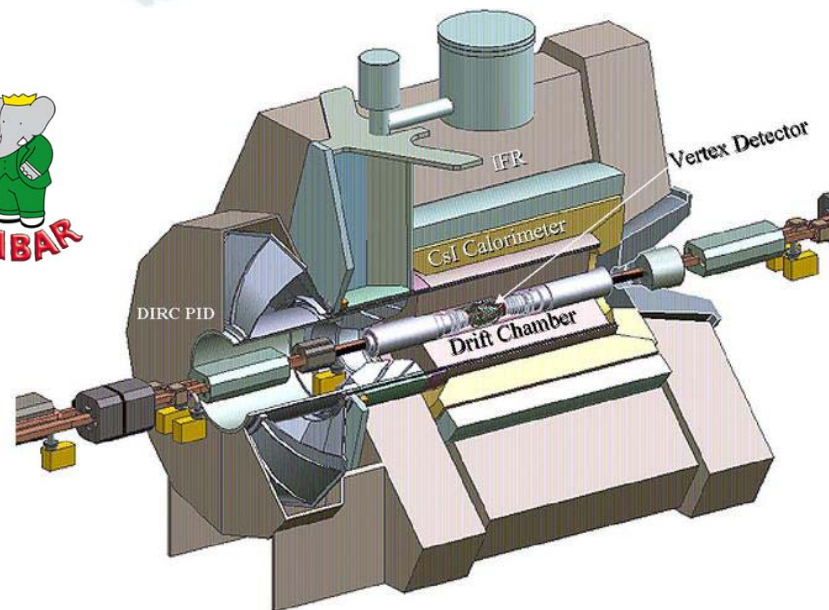
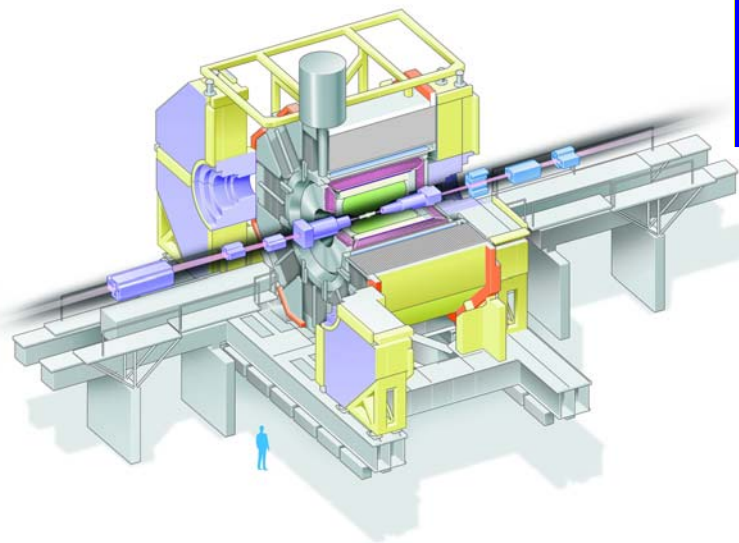

FIXED TARGET: FOCUS

- LARGE BOOST, ALL SPECIES AVAILABLE.
DEDICATED EXPERIMENT

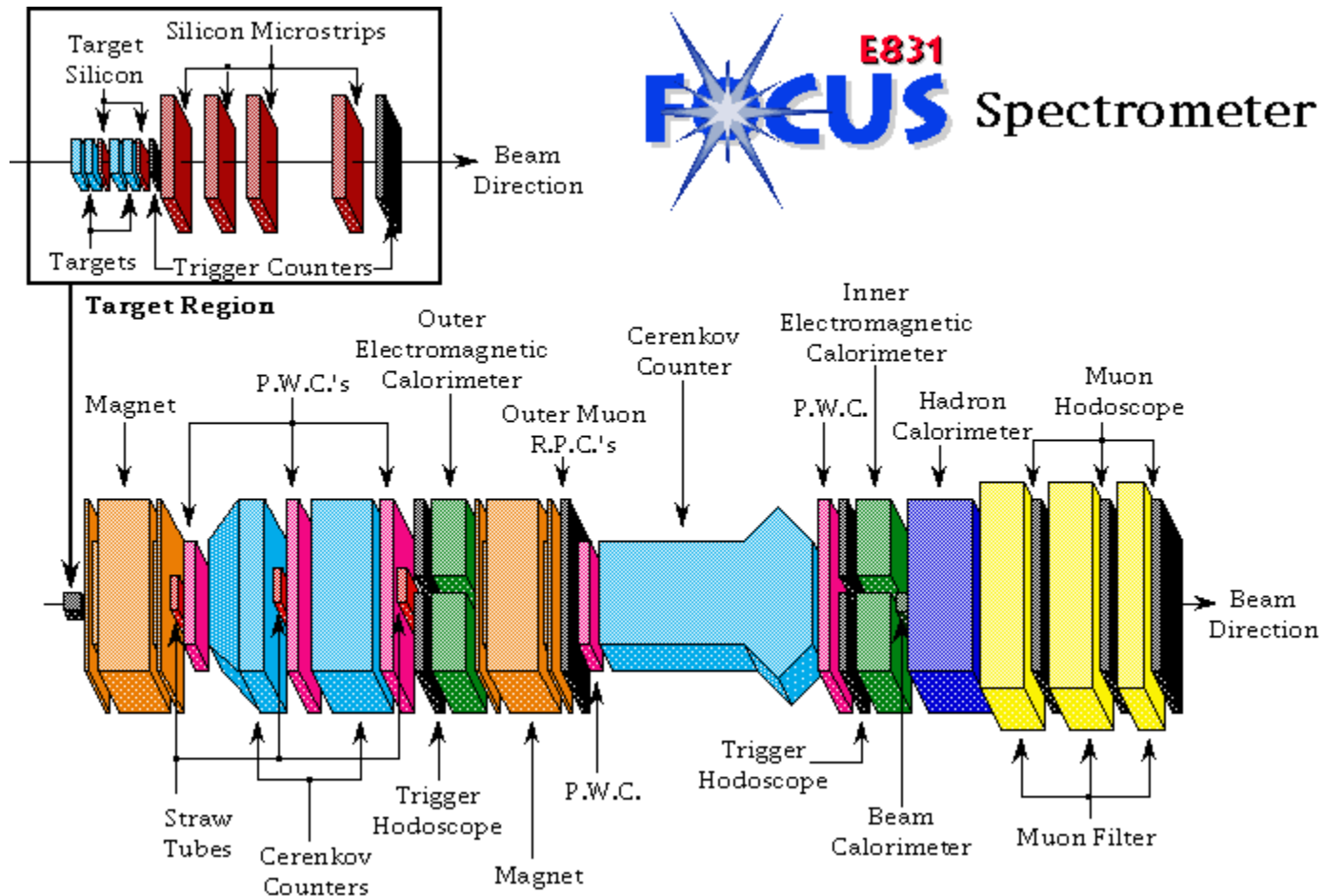

ENERGY FRONTIER: DØ & CDF

- ENORMOUS CROSS-SECTIONS
- LARGE BOOST
- ALL SPECIES AVAILABLE
- GOOD DIMUON TRIGGERS
- LOTS OF DATA AND COLLECTING MUCH MORE

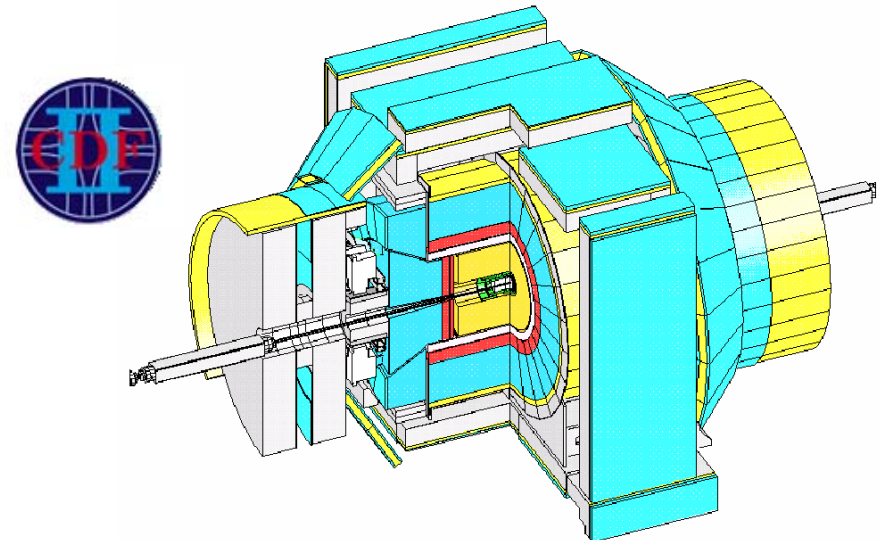
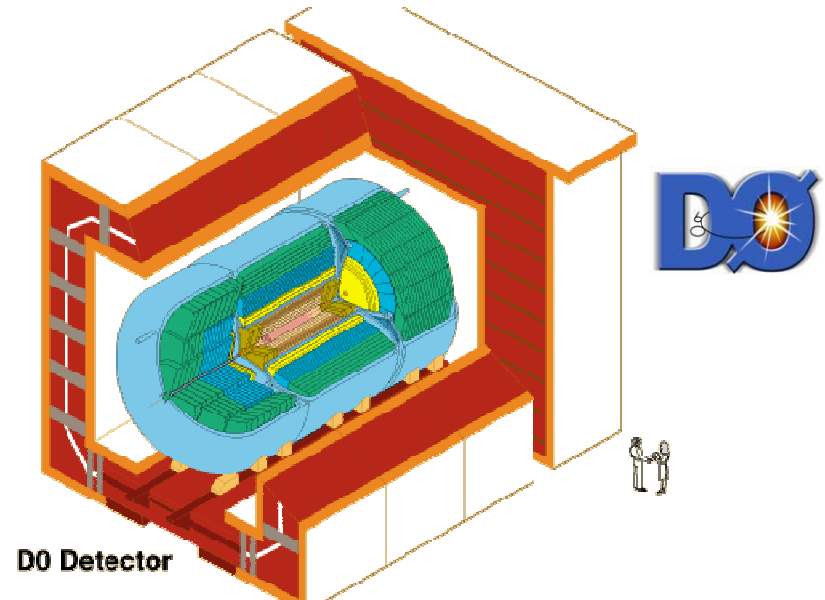

SOME COMPARISONS

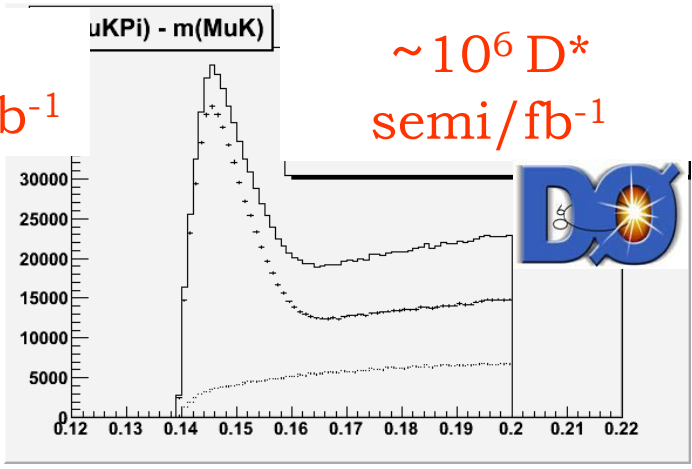
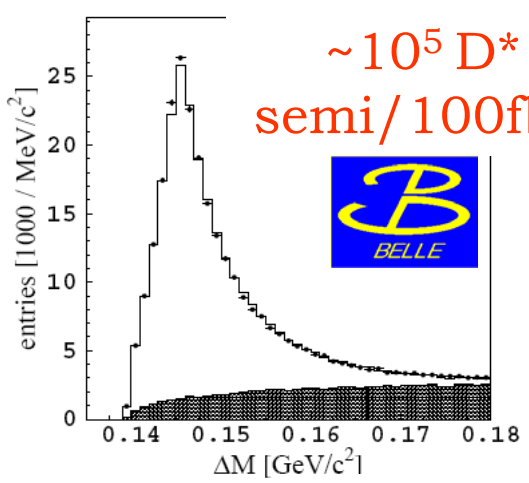

A TON OF DATA
AT THE
TEVATRON
WAITING FOR
YOU!

$m(K\pi\mu) - m(K\pi)$

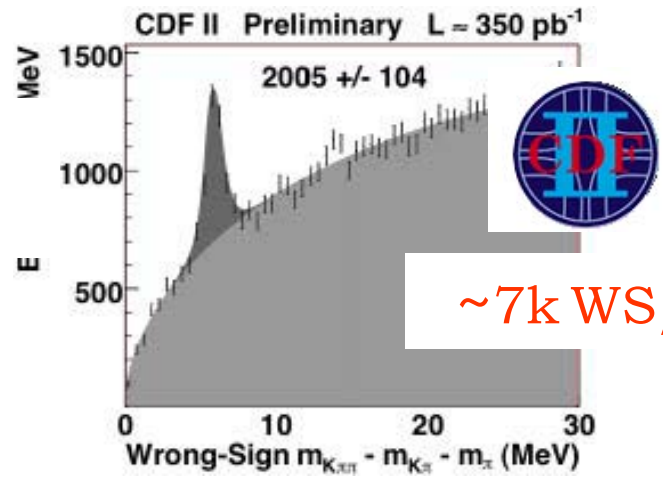
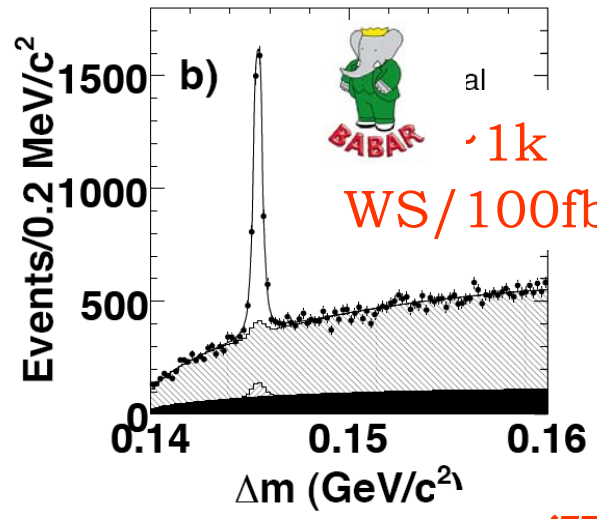

$\sim 7k$ WS/fb⁻¹

$m(K\pi\pi) - m(K\pi)$

CHARGED LEPTONIC DECAYS

- NEW THIS SUMMER: BELLE $D_s \rightarrow \mu\nu$
 - COVERED IN DETAIL TOMORROW BY LAURENZ WIDHALM

$$B(D_s \rightarrow \mu\nu) = (6.44 \pm 0.76 \pm 0.52) \times 10^{-3}$$

BELLE
PRELIMINARY

- MY COMBINATION PDG'06, BELLE, BABAR 07, CLEO-C 07:

$$B(D_s \rightarrow \mu\nu) = (6.25 \pm 0.49) \times 10^{-3}$$

- NOW MEASURED TO $\sim 8\%$
 - $\sim 37\%$ ERROR IN $B \rightarrow \tau\nu$

NP LIMITS?

RATIO:
$$\frac{\Gamma(D_s \rightarrow \tau\nu)}{\Gamma(D_s \rightarrow \mu\nu)} = \frac{m_\tau^2}{m_\mu^2} \times \frac{(m_{D_s}^2 - m_\tau^2)^2}{(m_{D_s}^2 - m_\mu^2)^2}$$

MY COMB: $B(D_s \rightarrow \tau\nu) = (7.28 \pm 1.00)\%$

EXP/THEORY $\tau\nu/\mu\nu$: $R\left(\frac{\tau\nu}{\mu\nu}\right) = 0.73 \pm 0.12$

EXP/THEORY $B \rightarrow \tau\nu$: $R(B \rightarrow \tau\nu) = 0.9 \pm 0.4$

CARENA++ HEP-PH/0704.1143 + UTFIT

EXP/THEORY $B \rightarrow D^*\tau\nu$: $Order(30\%)$

PRECISION LOOKING FOR A THEORY

NEUTRAL LEPTONIC DECAYS

NORMALIZE TO, THEN VETO D^* TAGGED $\pi\pi$.

FAKES MEASURED WITH D^* TAGGED $K\pi$

$>7 \text{ k } \pi\pi$

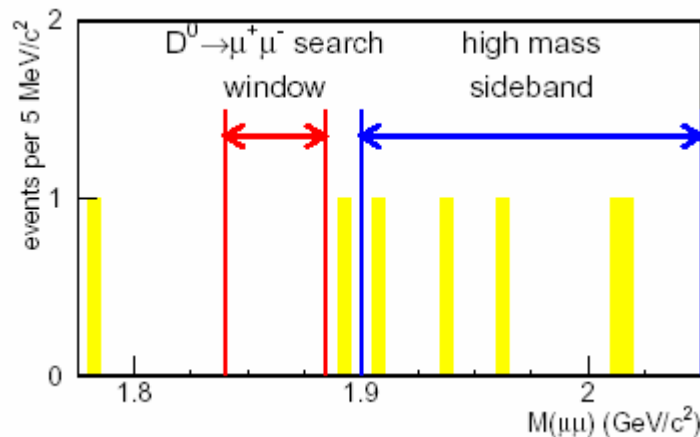
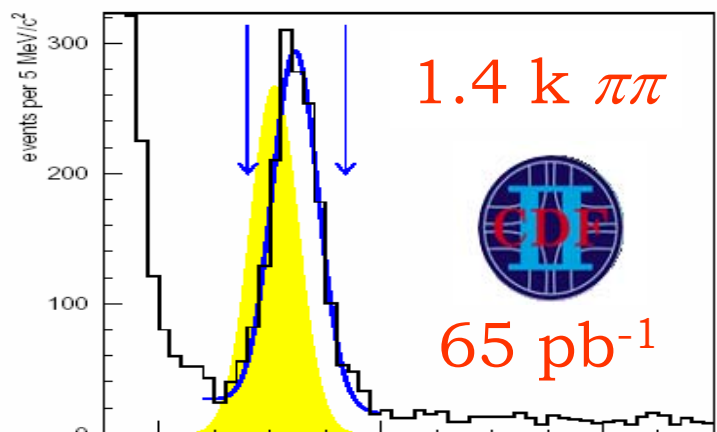

$$B(D \rightarrow \mu^+ \mu^-) < 2.5 \times 10^{-6}$$

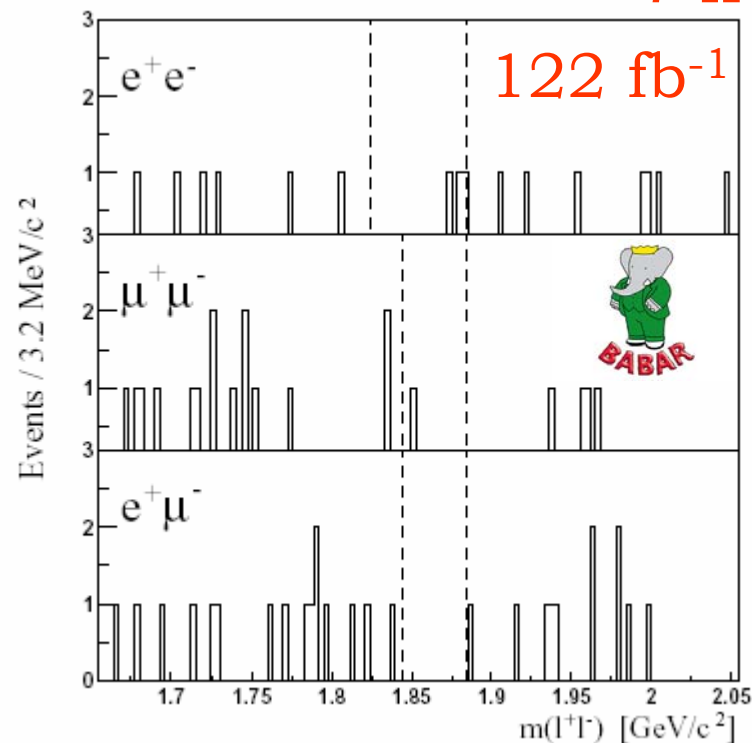

$$B(D^0 \rightarrow \mu^+ \mu^-) < 1.3 \times 10^{-6}$$

$$B(D^0 \rightarrow e^+ e^-) < 1.2 \times 10^{-6}$$

NEUTRAL LEPTONIC DECAYS

NORMALIZE TO, THEN VETO D^* TAGGED $\pi\pi$.

FAKES MEASURED WITH D^* TAGGED $K\pi$

>7 k $\pi\pi$

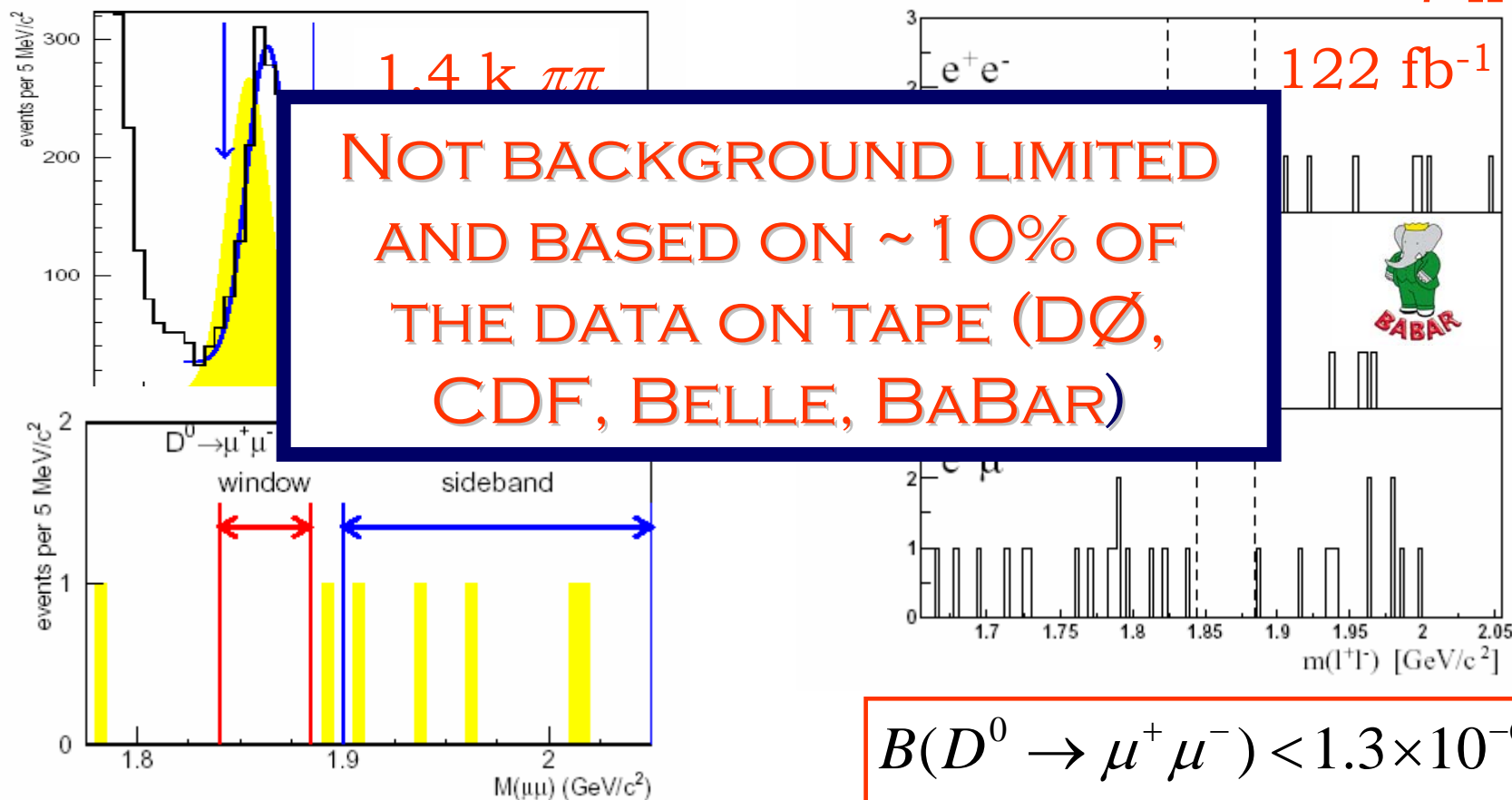

$$B(D \rightarrow \mu^+ \mu^-) < 2.5 \times 10^{-6}$$

$$B(D^0 \rightarrow \mu^+ \mu^-) < 1.3 \times 10^{-6}$$

$$B(D^0 \rightarrow e^+ e^-) < 1.2 \times 10^{-6}$$

2-BODY RADIATIVE

SHORT DISTANCE

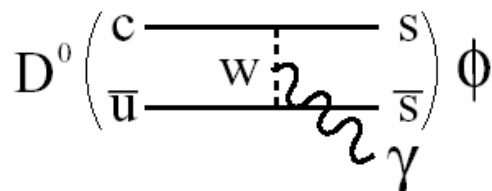

LONG DISTANCE

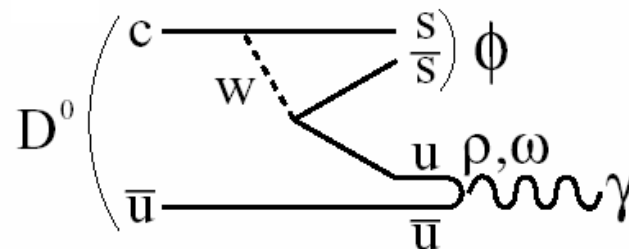

PEAKING BACKGROUNDS NOT MEASURED SO MEASURE THEM FIRST

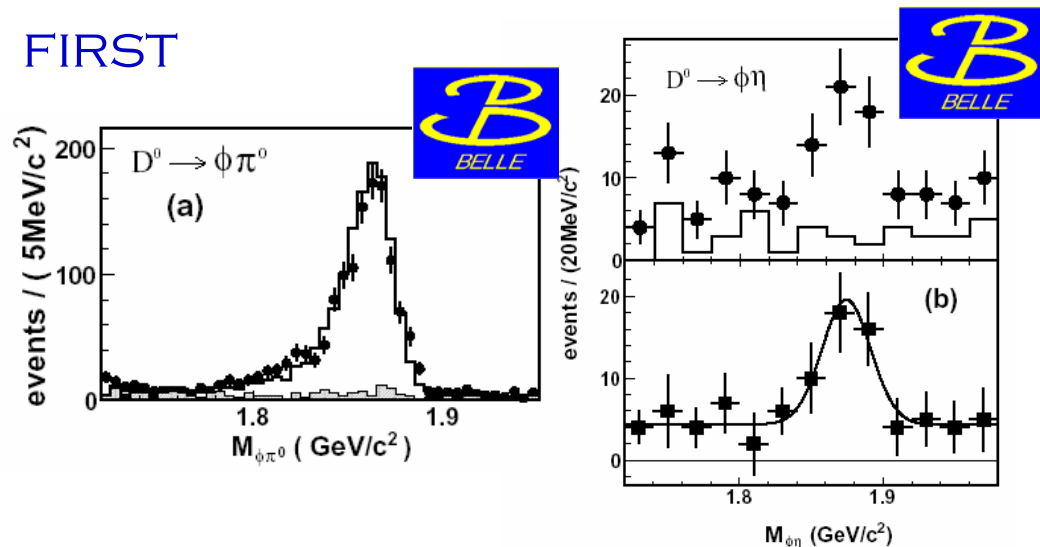

$$B(D^0 \rightarrow \phi\gamma) = (2.60^{+0.70+0.15}_{-0.61-0.17}) \times 10^{-5}$$

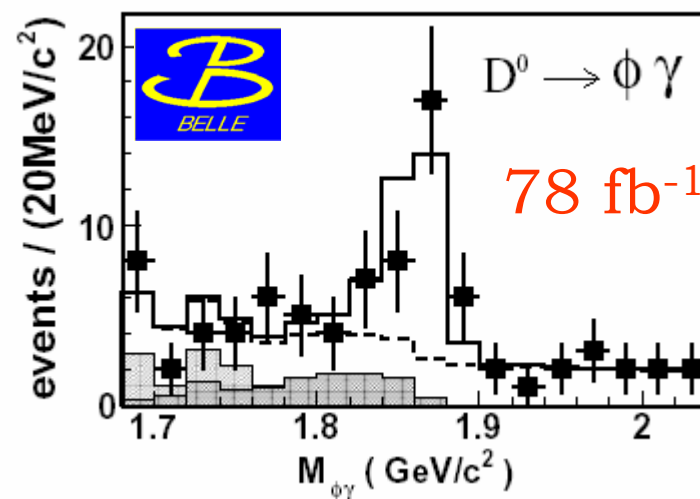

FIRST RADIATIVE CHARM DECAY

2 VRS 3 BODY RADIATIVE

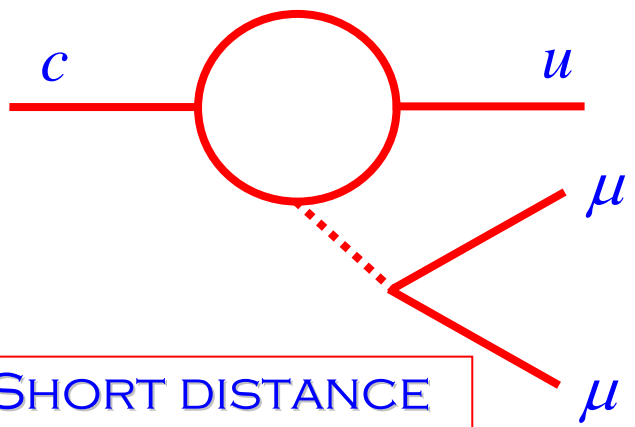

TWO PROCESSES: LONG DISTANCE (STRONG SCALE), SHORT DISTANCE (WEAK SCALE)

SHORT DISTANCE

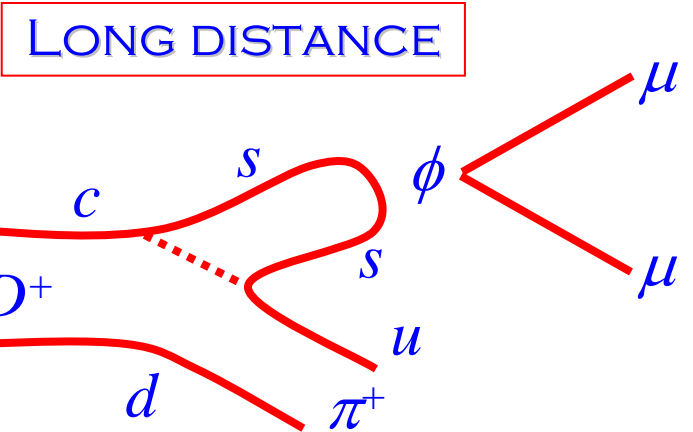

LONG DISTANCE

Burdman et al.
hep-ph/0112235

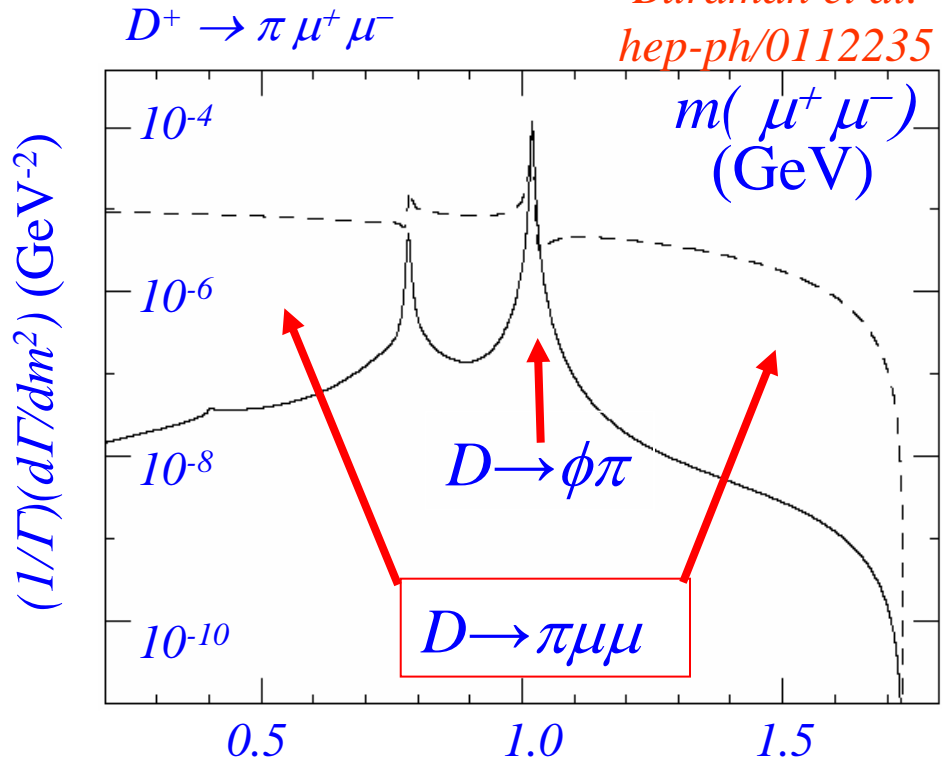

CLEAR SEPARATION OF LONG DISTANCE AND SHORT DISTANCE COMPONENTS

FOCUS

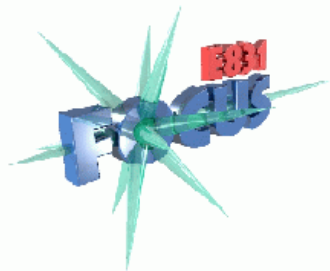

1996-1997 FIXED
TARGET RUN DATA

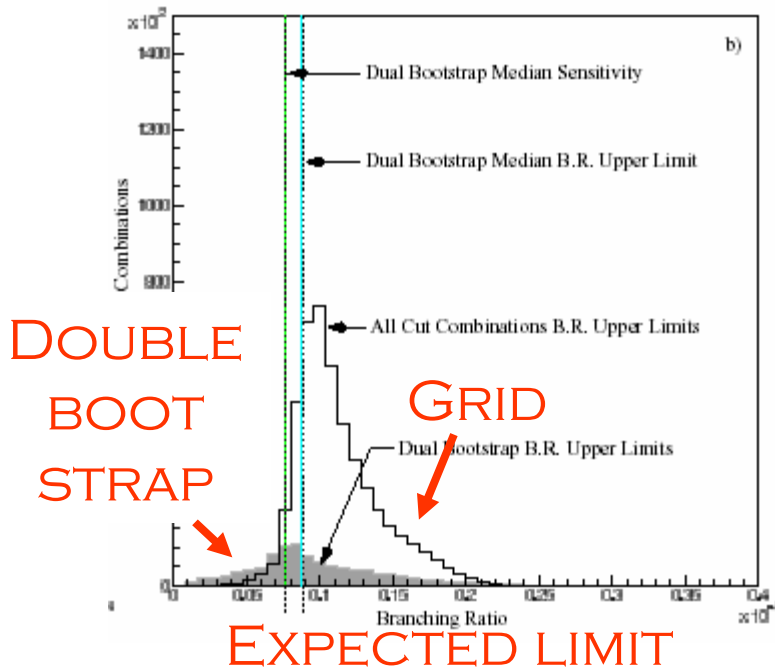
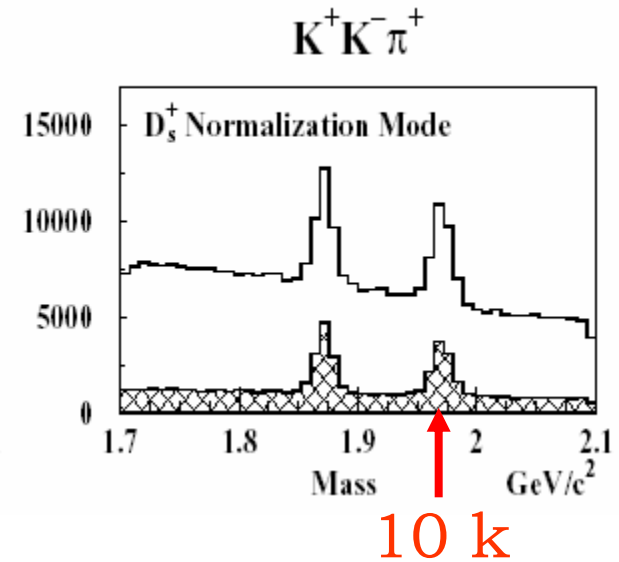
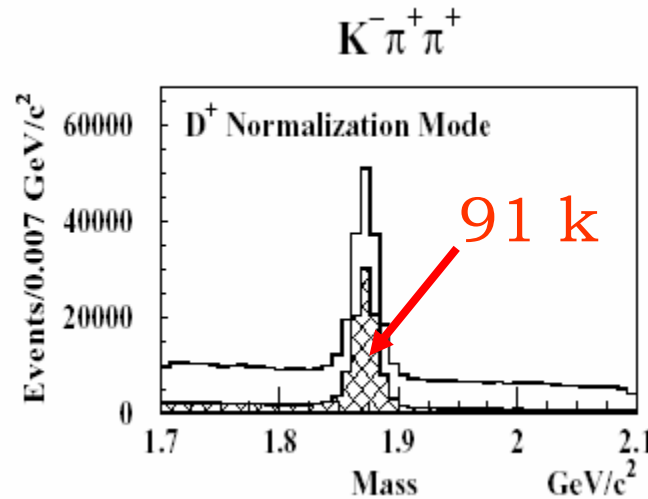

BACKGROUND REDUCTION
TAKES ADVANTAGE OF VERY
LARGE BOOST

GOOD PID SYSTEM TO
SEPARATE MODES

LOTS OF EFFORT INTO
GETTING VERY BEST LIMIT OUT

FOCUS RESULTS

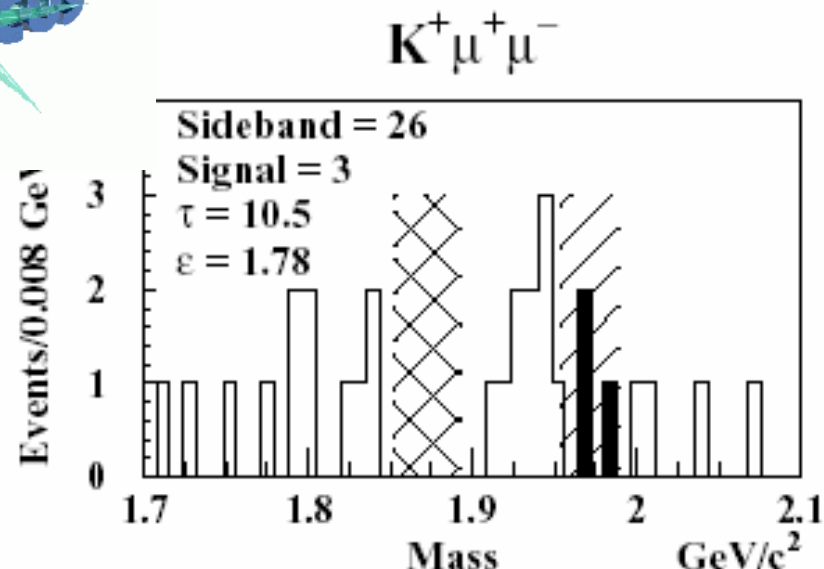
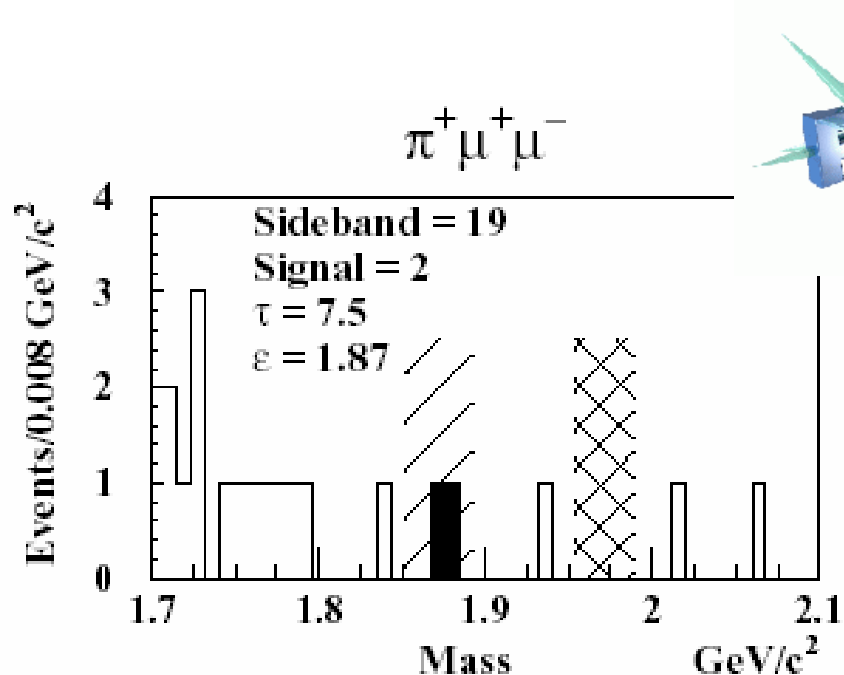

$$B(D^+ \rightarrow \pi^+ \mu^+ \mu^-) < 8.8 \times 10^{-6}$$

$$B(D_s^+ \rightarrow K^+ \mu^+ \mu^-) < 36 \times 10^{-6}$$

ALSO SEVERAL FORBIDDEN DECAY CHANNEL RESULTS IN
BACKUP

NUMBER TO BEAT FOR B FACTORIES AND TEVATRON

281 pb⁻¹ AT $\psi(3770)$

1.6 MILLION D[±]

USE BEAM KINEMATICS

DOUBLE SEMILEPTONICS
REMOVED WITH MISSING
ENERGY TYPE VETOS

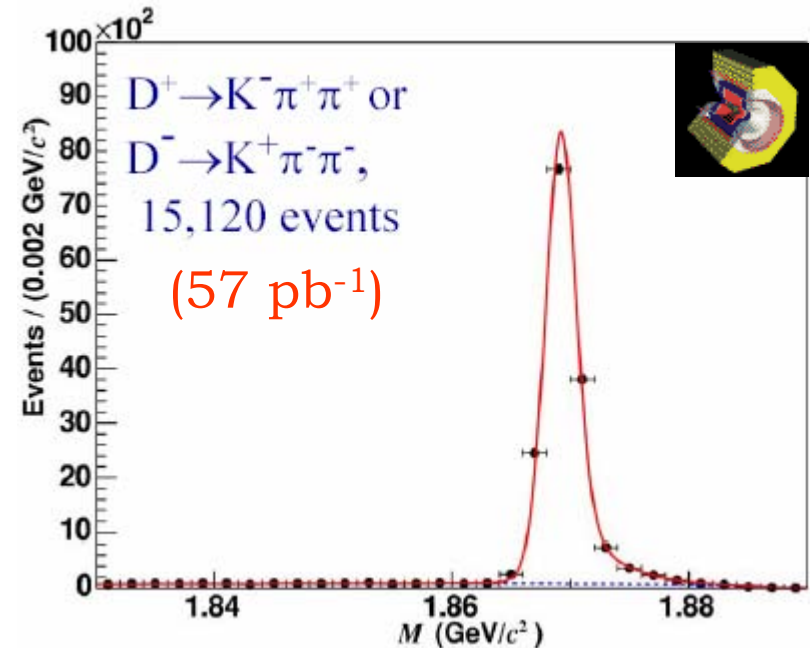

FOCUS ON THE DI-ELECTRON MODE

~0.1% FAKES FROM PEAKING BACKGROUNDS

ABSOLUTE BF MEASUREMENT

CLEO-C RESULTS

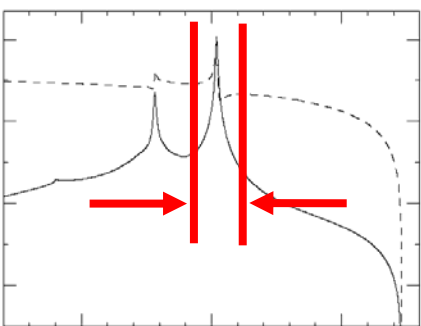

$m(e^+e^-)$

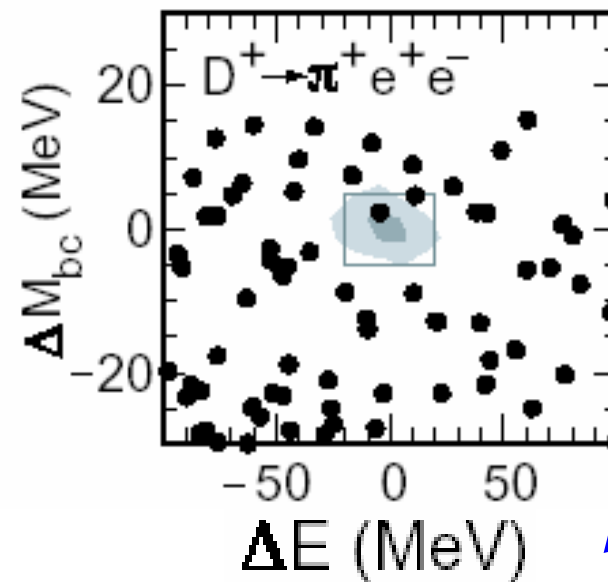
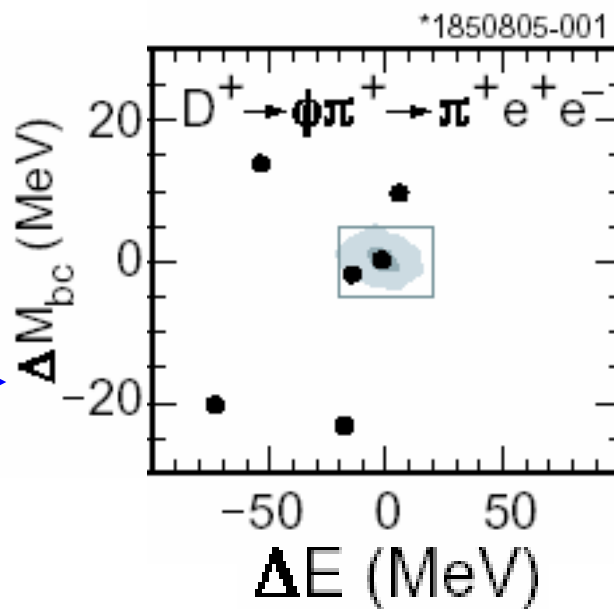

$$B(D^+ \rightarrow \pi^+ \phi \rightarrow \pi^+ e^+ e^-) = (2.7_{-1.8}^{+3.6} \pm 0.2) \times 10^{-6}$$

$$B(D^+ \rightarrow \pi^+ e^+ e^-) < 7.4 \times 10^{-6}$$

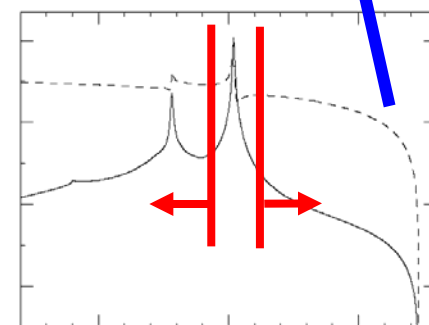

$m(e^+e^-)$

288 FB^{-1}

VERY SIMILAR TO CLEO
APPROACH

SELECT CONTINUUM D'S
TO BE ABLE TO MAKE
MISSING ENERGY VETOS

EXPANDED TO INCLUDE
ALL HADRON SPECIES
AND BOTH DI-ELECTRONS
AND DI-MUONS

2-D Missing energy veto

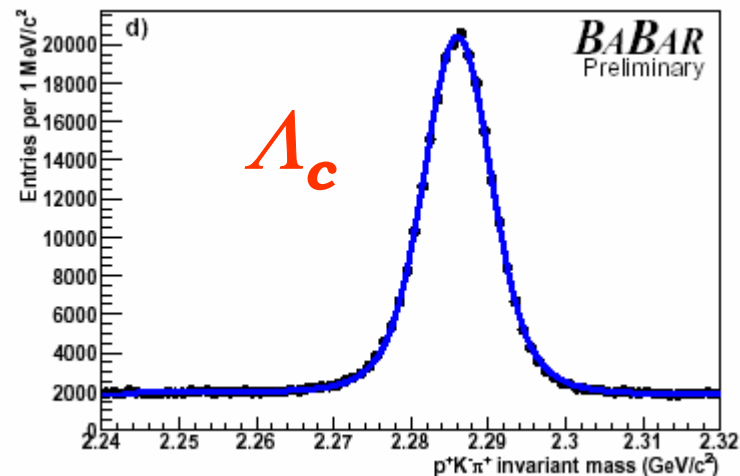
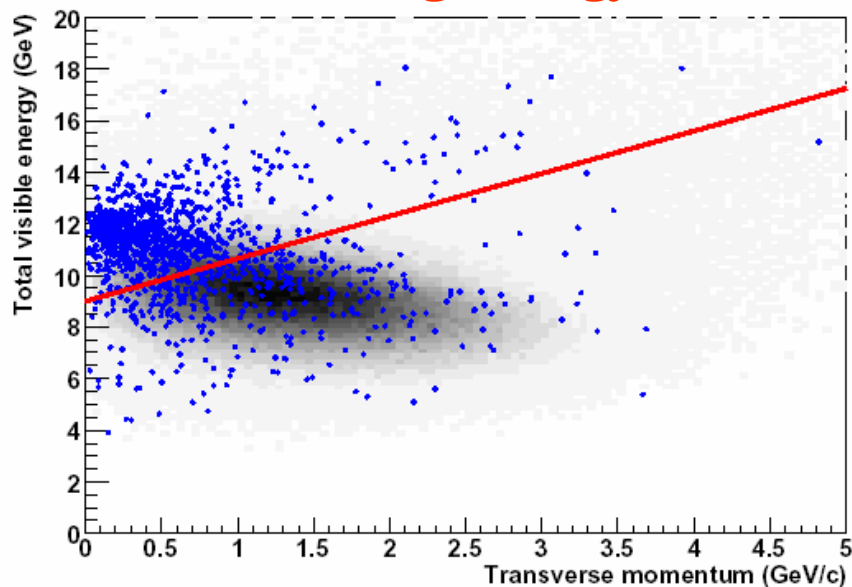

BABAR RESULTS

$e^+ e^-$

π

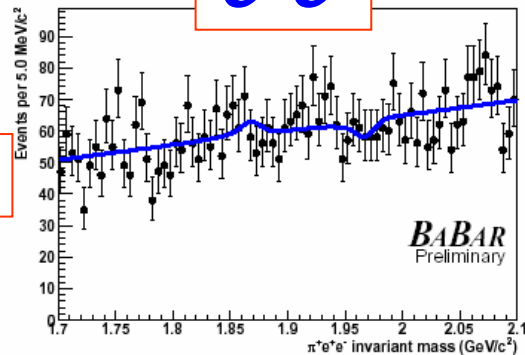

$\mu^+ \mu^-$

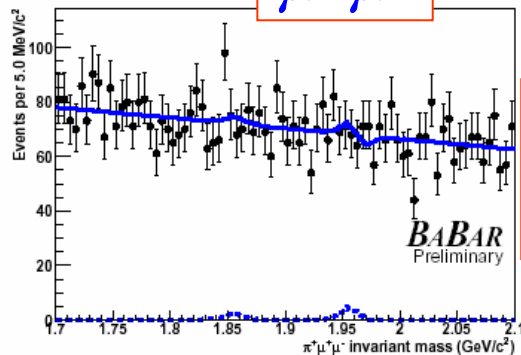

$$B(D^+ \rightarrow \pi^+ e^+ e^-) < 11.2 \times 10^{-6}$$

$$B(D^+ \rightarrow \pi^+ \mu^+ \mu^-) < 24.4 \times 10^{-6}$$

K

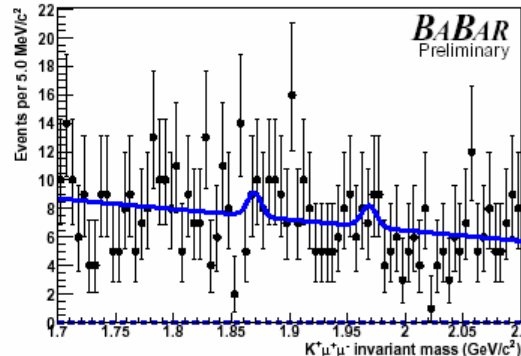
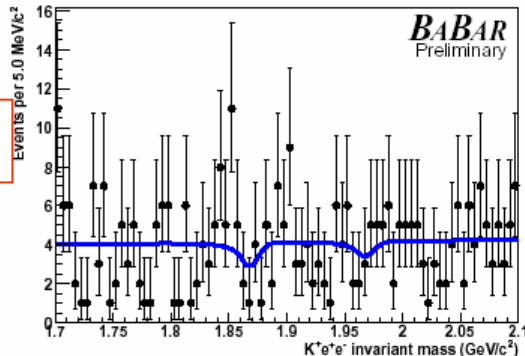

$$B(D_s^+ \rightarrow K^+ e^+ e^-) < 11.2 \times 10^{-6}$$

$$B(D_s^+ \rightarrow K^+ \mu^+ \mu^-) < 6.6 \times 10^{-6}$$

p

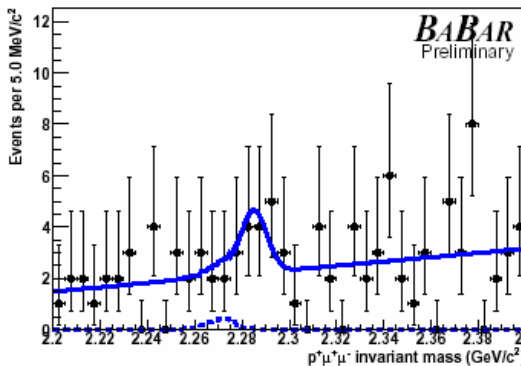
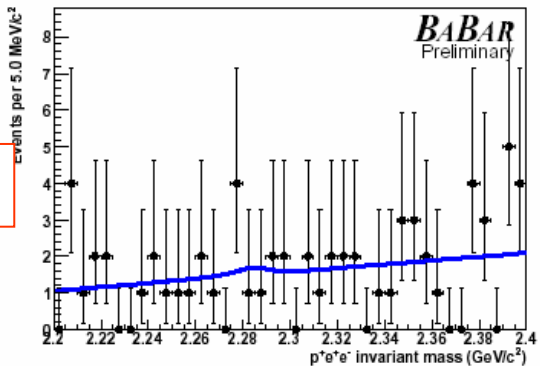

$$B(\Lambda_c \rightarrow p e^+ e^-) < 3.6 \times 10^{-6}$$

$$B(\Lambda_c \rightarrow p \mu^+ \mu^-) < 40.4 \times 10^{-6}$$

1.3 FB⁻¹, VERY SIMILAR TO FOCUS APPROACH

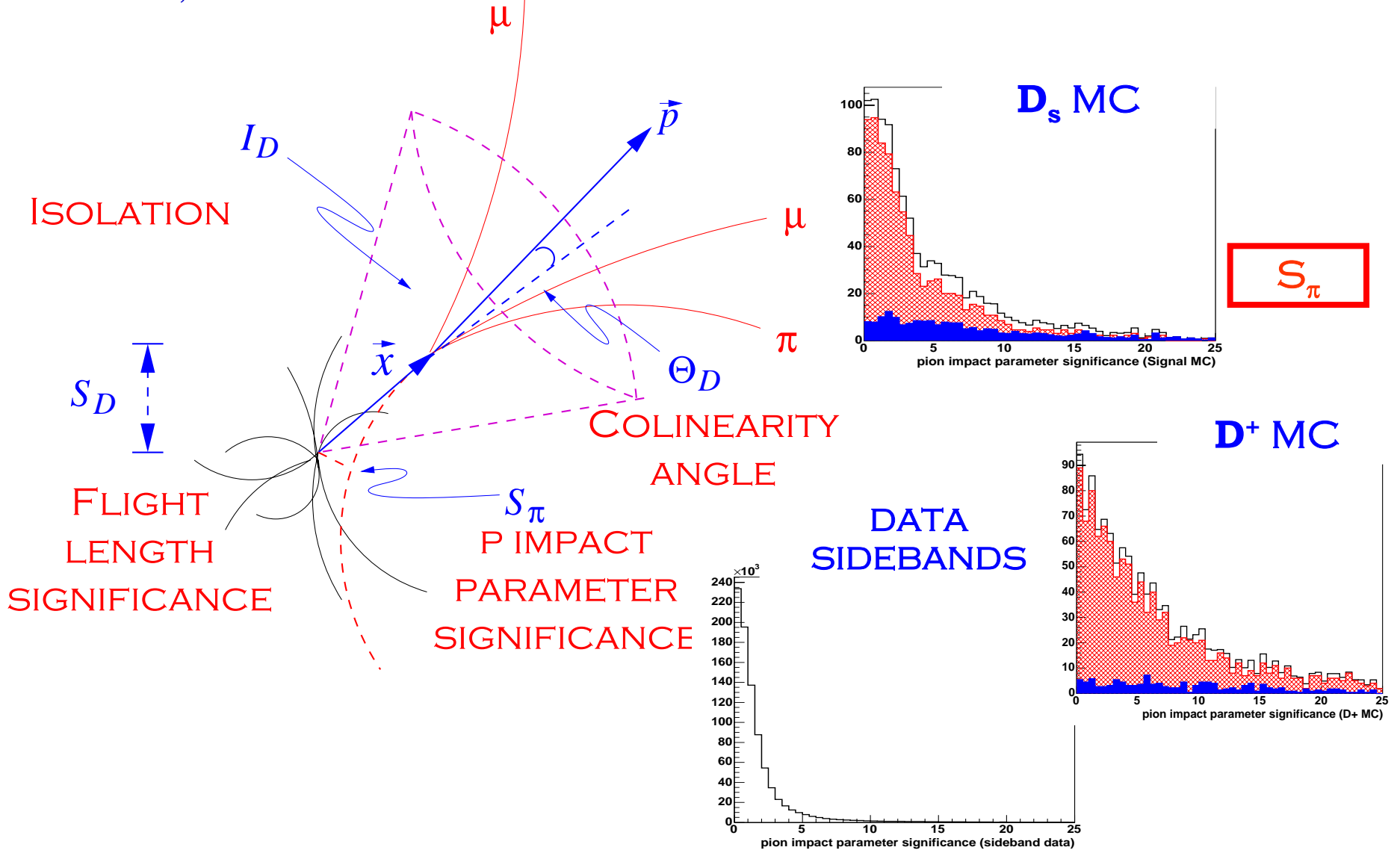

1.3 FB⁻¹, VERY SIMILAR TO FOCUS APPROACH

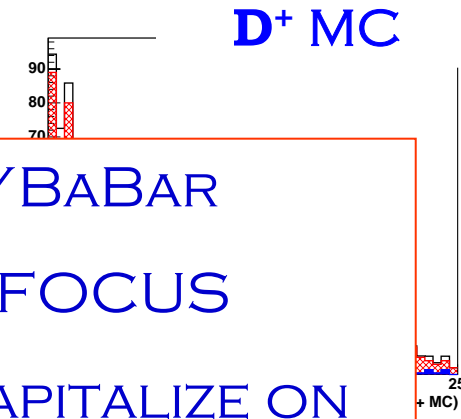
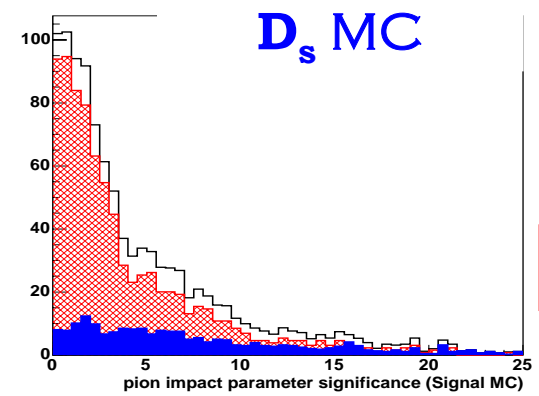
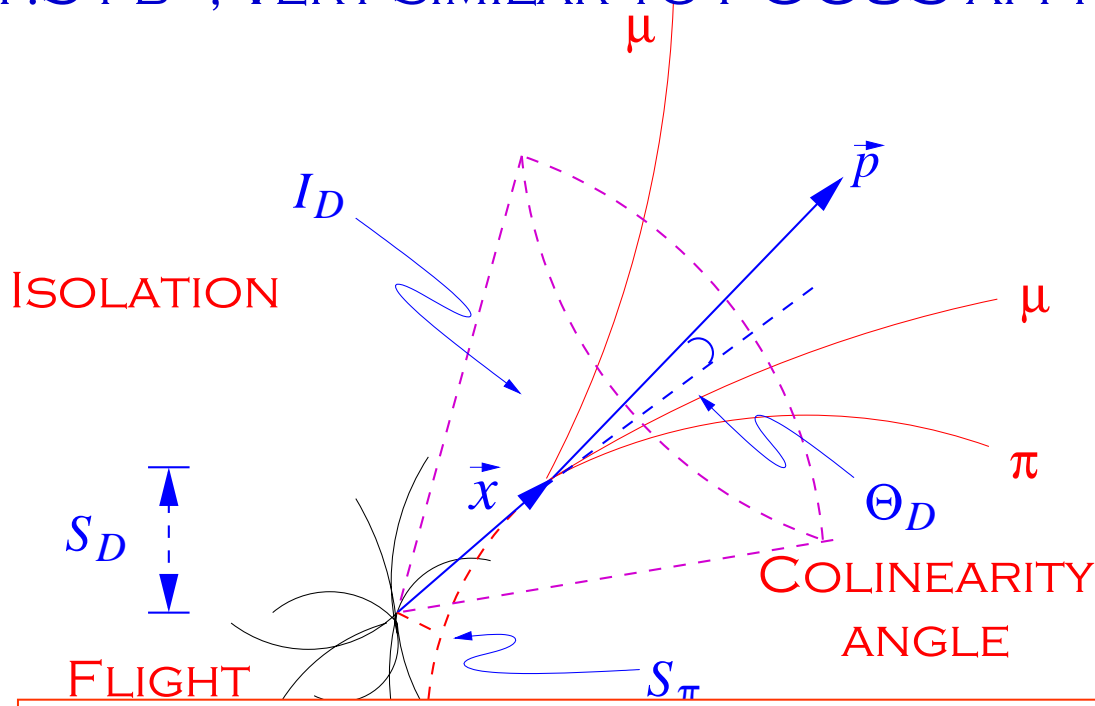

S

CANT MAKE MISSING ENERGY VETO LIKE CLEO/BABAR
DON'T HAVE PARTICLE ID LIKE CLEO/BABAR/FOCUS
OUTSTANDING MUON SYSTEM ALLOWS US TO CAPITALIZE ON ENORMOUS CROSS SECTION WITH NO PUNCH THROUGH

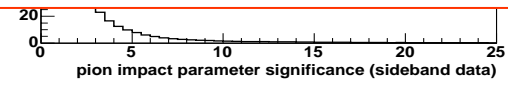

DØ RESULTS

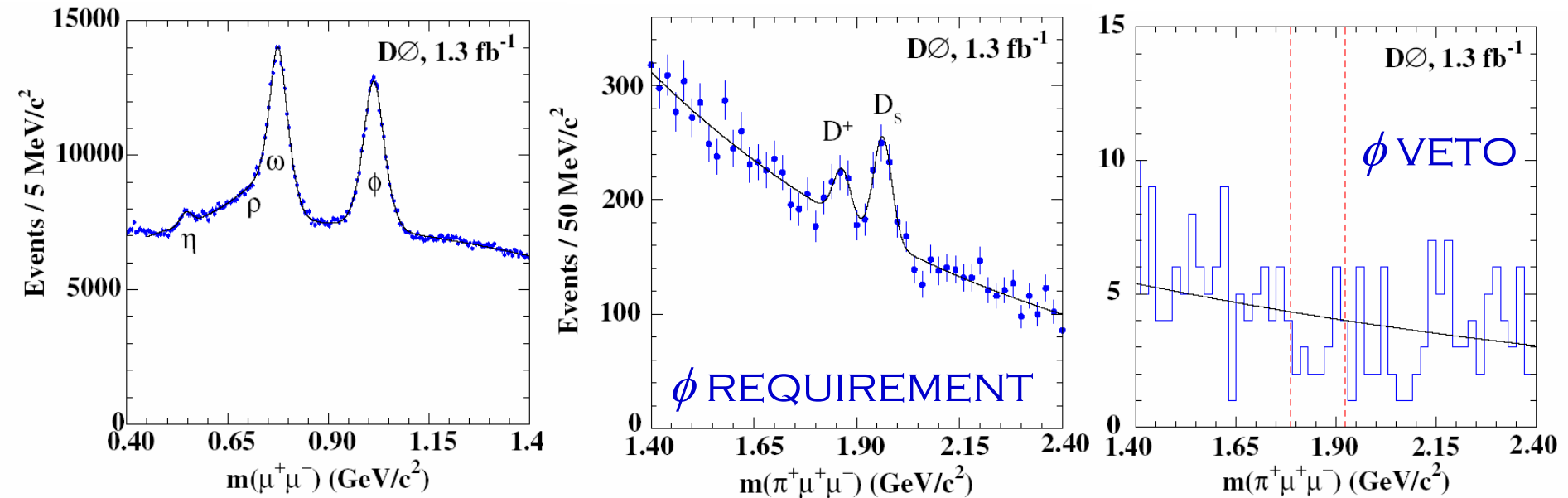

$$B(D^+ \rightarrow \pi^+ \phi \rightarrow \pi^+ \mu^+ \mu^-) = (1.8 \pm 0.5 \pm 0.6) \times 10^{-6}$$

$$B(D^+ \rightarrow \pi^+ \mu^+ \mu^-) < 3.9 \times 10^{-6}$$

1.3 FB⁻¹ #S UPDATED FOR THIS CONFERENCE

SOME COMPARISONS: $\phi\pi$

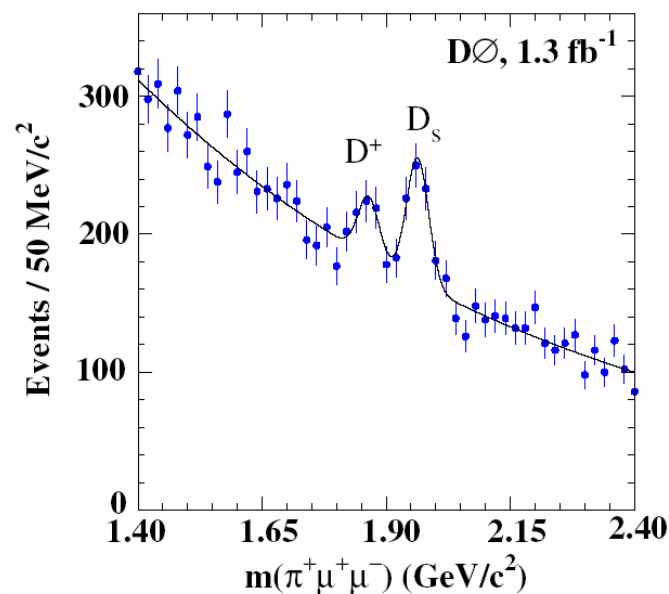
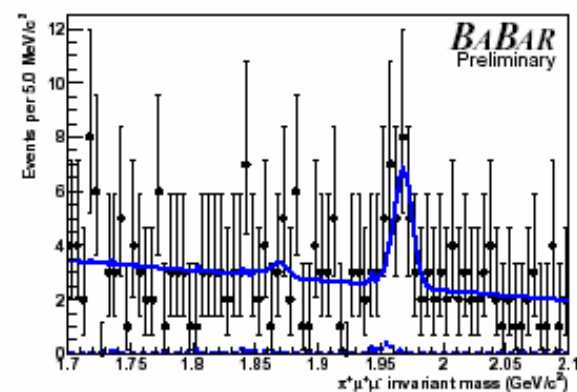
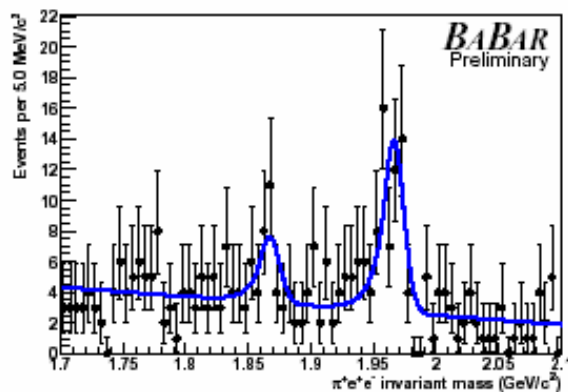
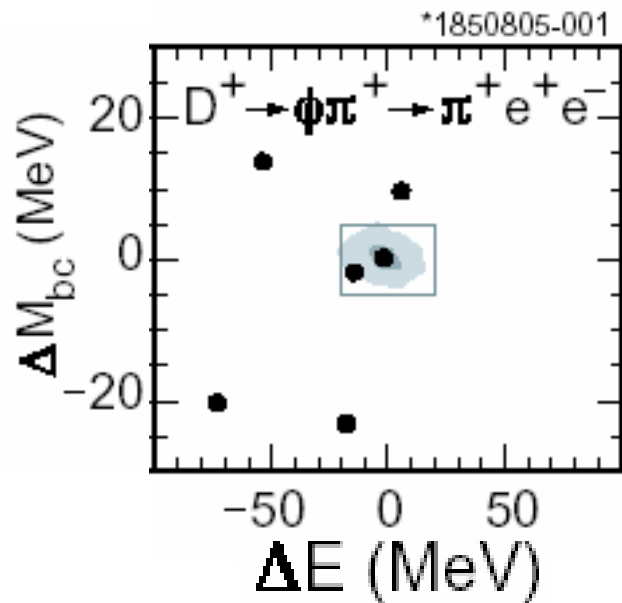

MILESTONE I: ALL THREE
HAVE REACHED
SENSITIVITY TO SEE $\phi\pi$ IN
THE $ll\pi$ CHANNEL

SOME COMPARISONS: ul^+l^-

MILESTONE II: ALL THREE HAVE SET LIMITS NEAR 10^{-6} LEVEL
USING MODES BEST SUITED FOR THEIR
EXPERIMENT/ENVIRONMENT

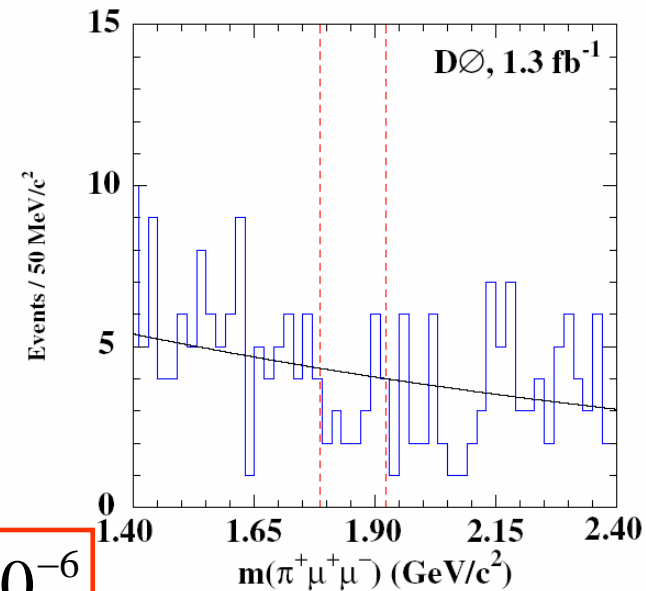
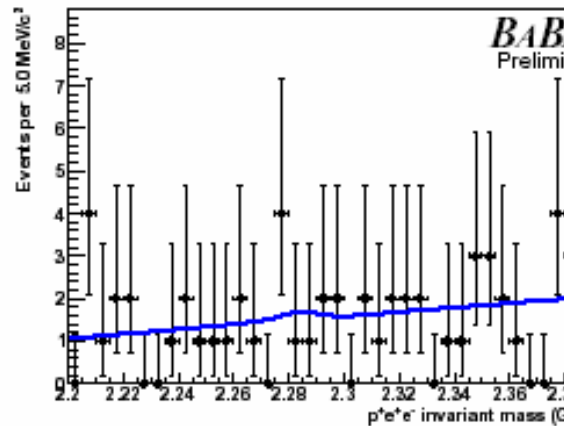
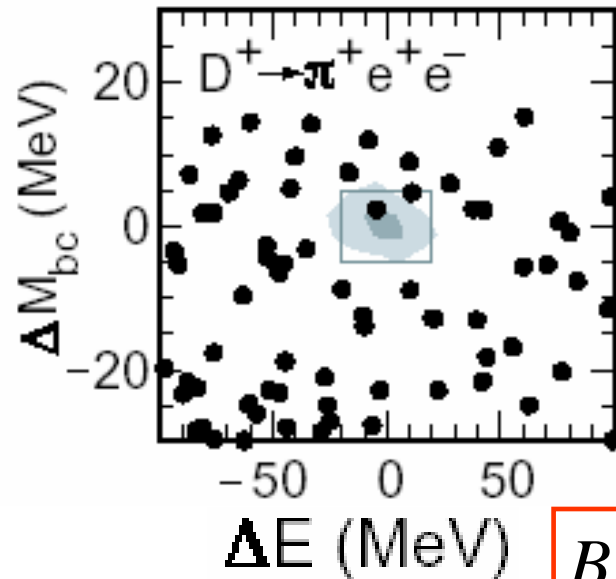

$$B(\Lambda_c \rightarrow pe^+e^-) < 3.6 \times 10^{-6}$$

$$B(D^+ \rightarrow \pi^+ e^+ e^-) < 7.4 \times 10^{-6}$$

$$B(D^+ \rightarrow \pi^+ \mu^+ \mu^-) < 3.9 \times 10^{-6}$$

SOME COMPARISONS: ul^+l^-

MILESTONE II: ALL THREE HAVE SET LIMITS NEAR 10^{-6} LEVEL
USING MODES BEST SUITED FOR THEIR
EXPERIMENT/ENVIRONMENT

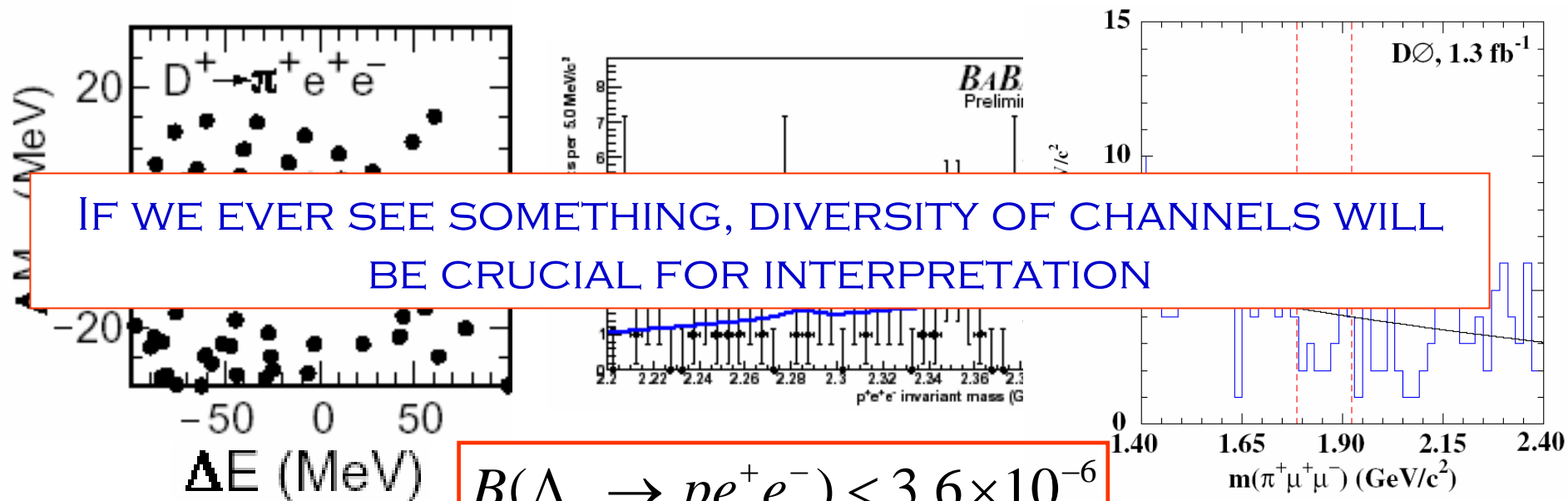

IF WE EVER SEE SOMETHING, DIVERSITY OF CHANNELS WILL
BE CRUCIAL FOR INTERPRETATION

$$B(D^+ \rightarrow \pi^+ e^+ e^-) < 7.4 \times 10^{-6}$$

$$B(\Lambda_c \rightarrow p e^+ e^-) < 3.6 \times 10^{-6}$$

$$B(D^+ \rightarrow \pi^+ \mu^+ \mu^-) < 3.9 \times 10^{-6}$$

$$10^{-6} \rightarrow 10^{-7} \text{ w/ } hl^+l^-$$

- BABAR: FRACTION OF DATA SET, BACKGROUND LIMITED
- BELLE: WHOLE DATA SET
- DØ: FRACTION OF DATA SET BUT BACKGROUND LIMITED
- CDF: WHOLE DATA SET
- ENOUGH DATA ON TAPE TO MAKE SIGNIFICANT PROGRESS AND MUCH MORE COMING
- KNOWING HOW TO DO THINGS LIKE COMBINE Λ_c AND D WOULD BE HELPFUL
- GETTING SMARTER ABOUT BACKGROUND SUPPRESSION REAL KEY

CONCLUSIONS

- NOT SO RARE
 - ANNIHILATION NOW AT PRECISION LEVEL
- RARE CHARM FROM 10^{-5} TO 10^{-6}
 - VERY DIVERSE SET OF RESULTS FROM 6 EXPERIMENTS AT 4 ENERGIES
 - NONE SPECIFICALLY DESIGNED FOR RARE CHARM
 - ALL BASICALLY DONE BY ONE OR TWO PEOPLE
- RARE CHARM AT 10^{-7}
 - DATA SETS WILL EXIST
 - LARGE FRACTION ALREADY ON TAPE

FOCUS FULL RESULTS

Decay Mode	Sensitivity	F-C	R-L	R-L incl. σ_r	Single Cut incl. σ_r
$D^+ \rightarrow K^+ \mu^+ \mu^-$	7.5	11	9.1	9.2	12
$D^+ \rightarrow K^- \mu^+ \mu^+$	4.8	13	13	13	12
$D^+ \rightarrow \pi^+ \mu^+ \mu^-$	7.6	9.3	8.7	8.8	7.4
$D^+ \rightarrow \pi^- \mu^+ \mu^+$	5.5	4.6	4.8	4.8	5.1
$D_s^+ \rightarrow K^+ \mu^+ \mu^-$	33	31	33	36	38
$D_s^+ \rightarrow K^- \mu^+ \mu^+$	21	11	13	13	20
$D_s^+ \rightarrow \pi^+ \mu^+ \mu^-$	31	20	24	26	18
$D_s^+ \rightarrow \pi^- \mu^+ \mu^+$	23	29	26	29	22

BABAR FULL RESULTS

	$D^0 \rightarrow e^+e^-$	$D^0 \rightarrow \mu^+\mu^-$	$D^0 \rightarrow e^\pm\mu^\mp$
N_{bg}^{hh}	0.02	3.34 ± 0.31	0.21
$N_{\text{bg}}^{\text{comb}}$	2.21 ± 0.38	1.28 ± 0.32	1.93 ± 0.36
N_{bg}	2.23 ± 0.38	4.63 ± 0.45	2.14 ± 0.36
$S [10^{-7}]$	2.25 ± 0.12	4.53 ± 0.30	3.27 ± 0.20
N_{obs}	3	1	0
UL obtained	1.2×10^{-6}	1.3×10^{-6}	8.1×10^{-7}

Decay mode	Yield (events)	Efficiency	BR (10^{-4}) (90% CL)	BF (10^{-6}) (90% CL)
$D^+ \rightarrow \pi^+e^+e^-$	$24.0^{+25.0+3.4}_{-24.1-5.1}$	3.93%	< 17.7	< 11.2
$D^+ \rightarrow \pi^+\mu^+\mu^-$	$1.5^{+20.1+3.4}_{-19.3-2.6}$	1.09%	< 38.7	< 24.4
$D^+ \rightarrow \pi^+e^+\mu^-$	$4.1^{+17.8+3.1}_{-16.3-2.1}$	2.27%	< 17.1	< 10.8
$D^+ \rightarrow \pi^+\mu^+e^-$	$-12.1^{+15.5+3.2}_{-14.8-0.0}$	2.29%	< 9.3	< 5.9
$D_s^+ \rightarrow \pi^+e^+e^-$	$-1.7^{+5.3+0.2}_{-4.6-2.0}$	1.14%	< 2.1	< 7.6
$D_s^+ \rightarrow \pi^+\mu^+\mu^-$	$-9.4^{+5.0+0.2}_{-4.4-1.4}$	0.31%	< 5.1	< 18.5
$D_s^+ \rightarrow \pi^+e^+\mu^-$	$4.8^{+4.7+0.8}_{-3.9-0.3}$	0.66%	< 6.2	< 22.3
$D_s^+ \rightarrow \pi^+\mu^+e^-$	$0.5^{+4.0+1.0}_{-3.3-0.1}$	0.65%	< 3.8	< 13.9
$D^+ \rightarrow K^+e^+e^-$	$5.9^{+8.9+3.8}_{-7.8-0.3}$	3.21%	< 8.2	< 5.2
$D^+ \rightarrow K^+\mu^+\mu^-$	$2.9^{+8.0+0.2}_{-7.0-3.7}$	0.75%	< 22.2	< 14.0
$D^+ \rightarrow K^+e^+\mu^-$	$-3.4^{+6.5+1.0}_{-5.6-0.1}$	1.64%	< 5.7	< 3.6
$D^+ \rightarrow K^+\mu^+e^-$	$-4.4^{+7.1+1.4}_{-6.1-3.0}$	1.64%	< 5.9	< 3.7
$D_s^+ \rightarrow K^+e^+e^-$	$-3.8^{+6.2+1.5}_{-5.3-1.3}$	2.81%	< 1.8	< 6.6
$D_s^+ \rightarrow K^+\mu^+\mu^-$	$5.0^{+6.5+0.1}_{-6.1-0.3}$	0.68%	< 7.1	< 25.4
$D_s^+ \rightarrow K^+e^+\mu^-$	$-3.7^{+5.1+1.4}_{-4.4-1.4}$	1.40%	< 1.5	< 5.6
$D_s^+ \rightarrow K^+\mu^+e^-$	$-6.5^{+4.9+0.2}_{-4.3-1.1}$	1.40%	< 1.0	< 3.6
$\Lambda_c^+ \rightarrow pe^+e^-$	$0.9^{+4.1+0.4}_{-3.4-0.1}$	4.11%	< 0.7	< 3.6
$\Lambda_c^+ \rightarrow p\mu^+\mu^-$	$6.9^{+4.7+0.3}_{-3.7-0.6}$	0.67%	< 8.1	< 40.4
$\Lambda_c^+ \rightarrow pe^+\mu^-$	$0.2^{+2.9+0.5}_{-2.0-0.5}$	1.19%	< 1.8	< 8.9
$\Lambda_c^+ \rightarrow p\mu^+e^-$	$-0.2^{+2.5+0.5}_{-1.7-0.9}$	1.18%	< 1.5	< 7.5

CLEO FULL RESULTS

Mode	ϵ (%)	N	n	σ_{syst} (%)	\mathcal{B} (10^{-6})
$\pi^+ e^+ e^-$	36.41	1.99	2	8.7	< 7.4
$\pi^- e^+ e^+$	43.85	0.48	0	7.1	< 3.6
$K^+ e^+ e^-$	26.18	1.47	0	10.0	< 6.2
$K^- e^+ e^+$	35.44	0.50	0	7.2	< 4.5
$\pi^+ \phi(e^+ e^-)$	46.22	0.04	2	7.4	$2.7^{+3.6}_{-1.8} \pm 0.2$