

# Proposal for the Aerogel Cherenkov Counters for the PEP-N Detector

M.Yu. Barnyakov, V.S. Bobrovnikov, A.R. Buzykaev, G.M. Kolachev,  
S.A. Kononov, E.A. Kravchenko, G.D. Minakov, A.P. Onuchin  
*Budker Institute of Nuclear Physics, Novosibirsk, Russia*  
A.F. Danilyuk  
*Boreskov Institute of Catalysis, Novosibirsk, Russia*  
F.F. Guber, A.B. Kurepin  
*Institute of Nuclear Research, Moscow, Russia*  
V.A. Krasnov  
*Joint Institute of Nuclear Research, Dubna, Russia*

The work is devoted to the development of the aerogel Cherenkov counters with the light collection on wavelength shifters and PMTs (ASHIPH). The ASHIPH system has been developed for the KEDR detector. Tests of the counters have been carried out on the Dubna accelerator, the  $\pi/K$  separation obtained is about  $4\sigma$ . The ASHIPH system is suggested for the PEP-N detector.

## 1. INTRODUCTION

The collaboration of Budker Institute of Nuclear Physics and Boreskov Institute of Catalysis has started the development of aerogel Cherenkov counters in 1986 [1] at Novosibirsk. The most important results of this work are the development of ASHIPH counters, development of the Monte Carlo code for simulation of Cherenkov light collection, and production of aerogel with high optical parameters.

The idea of the ASHIPH method is to use light guides with the wavelength shifting admixture for the light collection on PMT [2]. As compared with the direct light collection on PMT, the ASHIPH method allows the number of PMTs to be reduced essentially [3–6].

In order to simulate the processes of the light collection and propagation inside the aerogel Cherenkov counter a special code was developed in Budker Institute of Nuclear Physics [1, 2, 7]. This code simulates the following processes: Rayleigh scattering inside the aerogel, Lambert angular distribution of the reflected light from the walls, Fresnel refraction on the boundary of two continuous media, and a light absorption inside the aerogel and on the walls. Using this code we optimize the counter design and calculate the number of photoelectrons without production of series of prototypes.

We use the high optical properties aerogel SAN-96 [8–10] produced at Novosibirsk by collaboration of Boreskov Institute of Catalysis and Budker Institute of Nuclear Physics. The data on the light absorption (Labs) and scattering (Lsc) lengths in the SAN-96 aerogel are shown in Figure 1. The data for aerogel samples produced at KEK(Japan) [11] are also presented [6].

## 2. ASHIPH FOR KEDR

### 2.1. Layout

The ASHIPH system [6] for the KEDR detector [12] is shown in Figure 2. The system comprises 160 counters: 80 barrel (Figure 3) and 80 endcap counters (Figure 4). The total volume of aerogel is 800 liters. The use of aerogel with the refractive index 1.05 gives the possibility to separate pions and kaons in the momentum range  $0.6 \div 1.5$  GeV/c.

An important feature of the project is a two-layer design. The counter are arranged in such a way that a particle from the interaction point with a momentum above 0.6 GeV/c does not cross shifters in both layers simultaneously. It is possible to use the information from both layers for the essential part of the particles.

### 2.2. Reflector

We use the multi-layer PTFE film from Tetratex company as a reflector. The results of measurement [3] of the reflection coefficient for the different thickness of reflector are shown in Figure 5. The PTFE teflon has four times larger radiation length than the KODAK paint. Due to using teflon the amount of material in front of the calorimeter is significantly decreased.

### 2.3. BBQ wavelength shifter

The absorption spectrum of BBQ is presented in Figure 6 together with the spectrum of collected Cherenkov photons and the absorption spectrum of POPOP (KN-18). The production

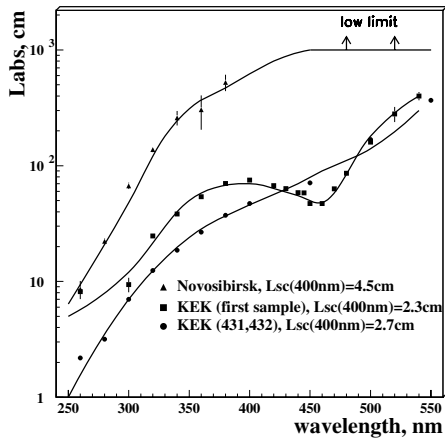

Figure 1: Labs and Lsc (in comments) for Novosibirsk and KEK aerogels.

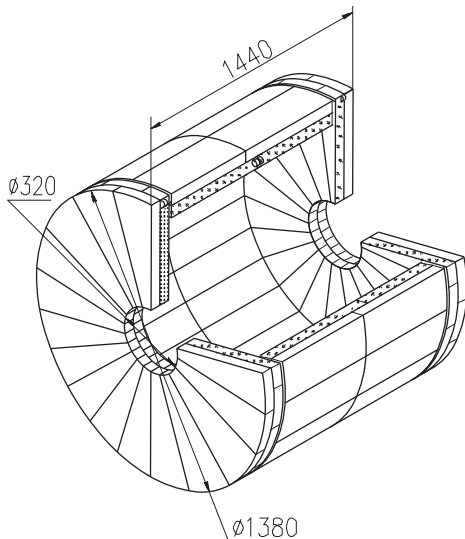

Figure 2: The KEDR ASHIPH system.

of plexiglass plates doped with BBQ was mastered in Institute of Polymers at Dzerzhinsk. The cutting, polishing, and twisting were organized in Budker Institute of Nuclear Physics [6].

**2.4. Microchannel plate PMT**

We use microchannel plate (MCP) PMTs with multialkali photocathode produced in Novosibirsk by “Ekran” plant [5, 6]. The size of this device is small: 31 mm diameter and 17 mm thickness. The photocathode is 18 mm in diameter. Our measurements of quantum efficiency (QE) of this PMT and the FM PMT R6150 are shown in Figure 7. The shift of spectral response to the region of longer wavelengths is the essential advantage of MCP PMTs in respect of detecting BBQ emission.

The decrease of MCP PMT multiplication gain in high magnetic field is not so strong as for fine mesh PMTs of Hama-

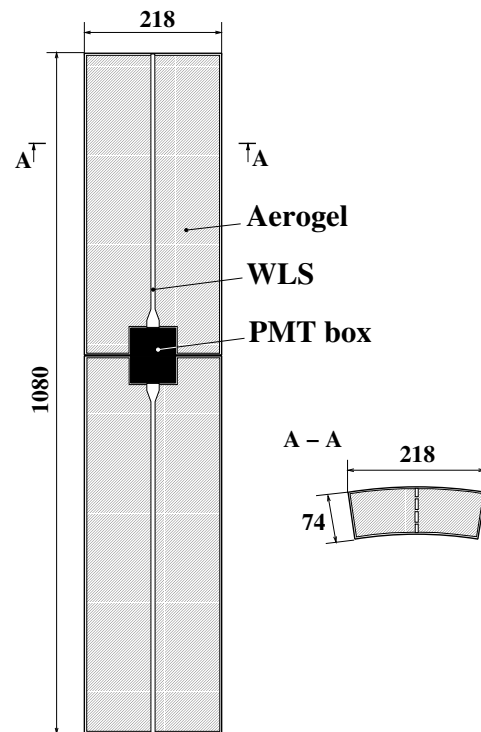

Figure 3: The barrel ASHIPH counter.

matsu. In the magnetic field of 1.5 Tesla the gain drops in some 5 times.

**2.5. Amount of material in the system**

The amount of material in the KEDR ASHIPH system is shown in Table I.

Table I The amount of material in the ACC system.

	Density, g/cm <sup>3</sup>	X <sub>0</sub> , cm	% of X <sub>0</sub>
Aerogel	0.243	112	6
Frame (Al)	2.7	8.9	4.3
WLS	1.49	34.4	0.3
PTFE	2.2	15.8	1.1
MCP PMT			0.2
Total 1 layer			11.9
Total 2 layers			24

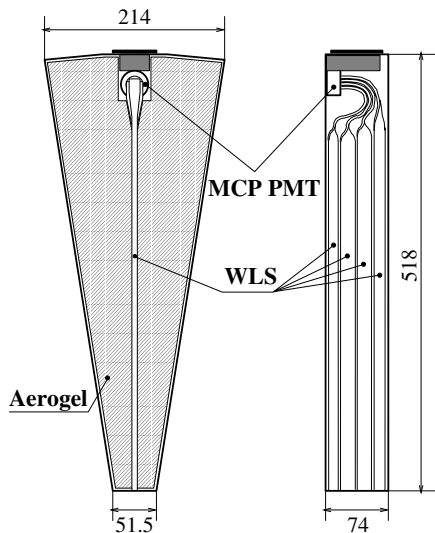

Figure 4: The endcap ASHIPH counter.

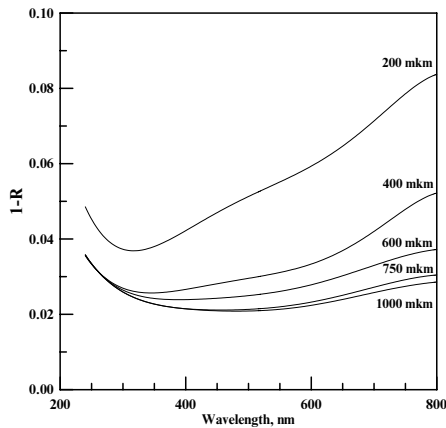

Figure 5: Reflection R of PTFE teflon.

### 3. TEST BEAM RESULTS FOR THE KEDR ASHIPH

#### 3.1. Layout of the experiment

The endcap counters of the KEDR detector were tested on the particle beam at the Dubna accelerator. The counters were filled with blocks of SAN-96 aerogel.

The tested counters were turned relative to the beam axis, so that particles traverse the counter at the same angle as in the KEDR detector. The time-of-flight counters with 30-m base were used to separate beam particles. A hodoscope of scintillation counters was used to determine coordinates, with which a particle passes the counter. The measurements were carried out with protons of 0.86 GeV/c–2.1 GeV/c momentum and pions of 0.86 GeV/c–1.6 GeV/c momentum.

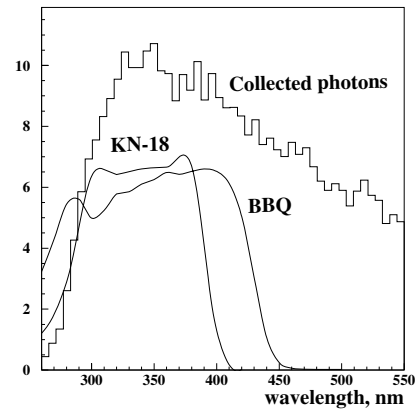
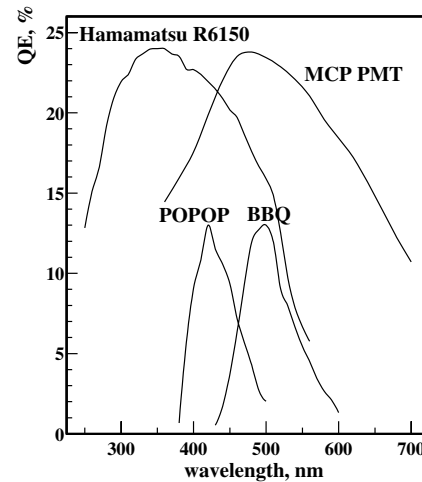

Figure 6: The absorption spectra of BBQ and KN-18 (POPOP) wavelength shifters, collected Cherenkov photons spectrum.

Figure 7: Hamamatsu R6150  $N^2$ -ZH2673 and Katod MCP PMT  $N^2$ -1570 quantum efficiencies. POPOP and BBQ emission spectra.

#### 3.2. Number of photoelectrons, counter homogeneity

The dependence of the detected Cherenkov light on momentum was measured with pions (Figure 8). The theoretical fit to the experimental point gives the resulting number of photoelectrons at  $\beta = 1$  as 10.6 pe.

The homogeneity of the light collection was measured with the 0.83 GeV/c pions over the whole area of the counter. As shown in the Figure 9, the signal varies from 7.1 pe up to 9.7 pe.

#### 3.3. $\pi/K$ separation

The data for kaons were obtained using protons with corresponding velocity. Figure 10 illustrates “kaon” and pion amplitude spectra obtained from the counter at  $P=0.86$  GeV/c.

In Figure 11 the probabilities of kaon and pion misidentification are shown as a function of threshold for 0.86 and 1.2 GeV/c momenta. For 0.86 GeV/c at the zero threshold on the amplitude the signal pion suppression factor is 860, with kaon detection efficiency being equal to 94% (separation is  $4.7\sigma$ ). And for 1.2 GeV/c pion suppression factor is 1300, with kaon detection efficiency being 90% ( $4.5\sigma$ ).

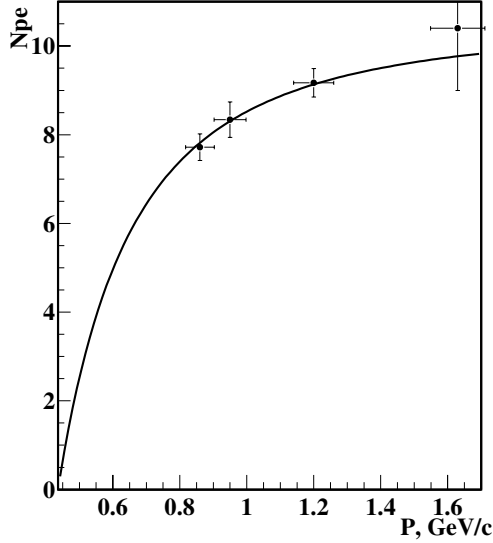

Figure 8: The number of photoelectrons for pions versus momentum. The curve represents the theoretical formula fit.

We would like to note that the aerogel counters system of the KEDR detector includes two layers and most of the particles will cross two counters in good conditions. For these particles the identification will be better.

#### 4. ASHIPH FOR PEP-N

The PEP-N experiment is proposed for the investigation of  $e^+e^-$  collisions in the c.m. energy from 1.4 to 3 GeV. The Aerogel Cherenkov Counter system is provided for  $\pi/K$  separation in the forward direction of the detector (Figs. 12,13).

The proposed system is analogous to the KEDR ASHIPH system. Total volume of aerogel is 350 liters. We suggest to use MCP PMTs in the counters. The refractive index of aerogel is 1.05. This provides the  $\pi/K$  identification in the momentum range from 0.6 to 1.5 GeV/c. Identification below 0.6 GeV/c is provided by dE/dX in coordinate system and TOF measurements with calorimeter.

The Monte Carlo calculations were performed for the  $e^+e^- \rightarrow K^+K^-\pi^+\pi^-$  reaction at  $E_{c.m.} = 2$  GeV. The momentum distribution of kaons in laboratory coordinates is shown in Figure 14. One can see that the identification region of the ASHIPH system covers the main part of the events.

The results on identification acceptance for 4 track events is presented in Table II. The tracker acceptance for this reaction is 88% for 4 tracks and 12% for 3 tracks.

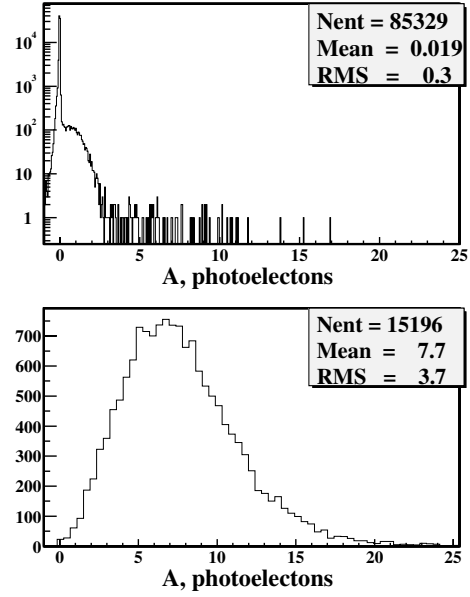

Figure 10: Amplitude spectra for kaons (top) and pions (bottom),  $P=0.86$  GeV/c.

Table II Identification acceptance for 4 track events.  $N_{ID}$  is the number of particles identified.

$N_{ID}$	Identification systems	Acceptance
4	dE/dX + TOF	2%
4	dE/dX + TOF + ASHIPH	48%
$\geq 3$	dE/dX + TOF	41%
$\geq 3$	dE/dX + TOF + ASHIPH	93%

The amount of material in the PEP-N ASHIPH system is about 20% of  $X_0$ .

#### 5. CONCLUSION

The use of high transparency aerogel, ASHIPH method together with the detailed Monte Carlo calculations have helped us to develop and construct the aerogel Cherenkov counters for the KEDR detector. The counters have been tested on beam,  $4\sigma\pi/K$  separation has been obtained.

The Aerogel Cherenkov Counters system is proposed for the PEP-N detector. This system is analogous to one developed for the KEDR detector. It provides  $4\sigma\pi/K$  separation in the momentum range  $0.6 \div 1.5$  GeV/c. Total volume of aerogel is 350 liters, amount of material in front of the calorimeter is about 20% of  $X_0$ .

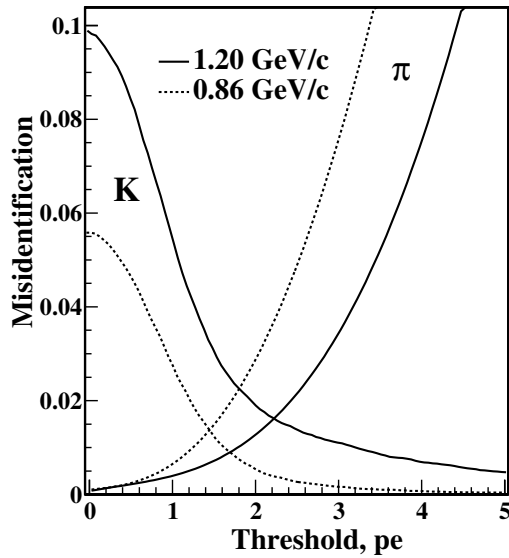

Figure 11: Probability of misidentification for kaons and pions as a function of threshold.  $P=0.86$  GeV/c,  $1.2$  GeV/c.

## REFERENCES

- [1] A.P.Onuchin, et al., 5th Int. Conf. Instr. for Colliding Beams Physics, Novosibirsk, 1990 (World Scientific,1990) p.208.
- [2] A.Onuchin et al., Nucl. Instr. and Meth. A 315 (1992) 517
- [3] A.R.Buzykaev et al., Nucl. Instr. and Meth. A 379 (1996) 453
- [4] A.R.Buzykaev et al., Journal of Non-Crystalline Solids 225 (1998) 381
- [5] M.Yu.Barnykov et al., Nucl. Instr. and Meth. A 419 (1998) 584

[6] M.Yu.Barnykov et al., Nucl. Instr. and Meth. A

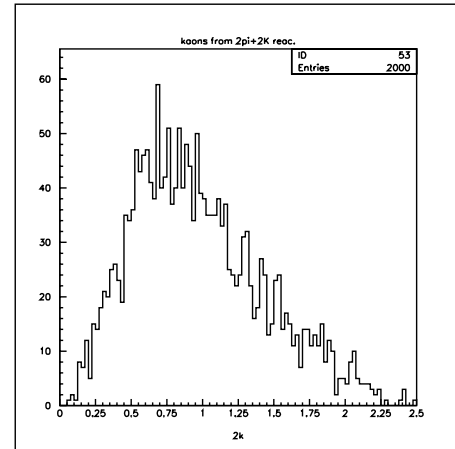

Figure 14: The momentum distribution of kaons in laboratory coordinates in the reaction  $e^+e^- \rightarrow K^+K^-\pi^+\pi^-$  at  $E_{c.m.} = 2$  GeV.

453 (2000) 326

- [7] A.G.Shamov and A.R.Buzykaev, Proc. of 'Computing in High Energy Physics 97', <http://www.ifh.de/CHEP97/paper/212.ps>
- [8] A.R.Buzykaev et al., Nucl. Instr. and Meth. A 379 (1996) 465
- [9] A.R.Buzykaev et al., Nucl. Instr. and Meth. A 433 (1999) 396
- [10] A.F.Danilyuk et al., Nucl. Instr. and Meth. A 433 (1999) 406
- [11] I.Adachi et al., Nucl. Instr. and Meth. A 355 (1995) 390
- [12] V.V.Anashin et al., "Status of the KEDR detector", Vienna Conf. on Instrum., 2001

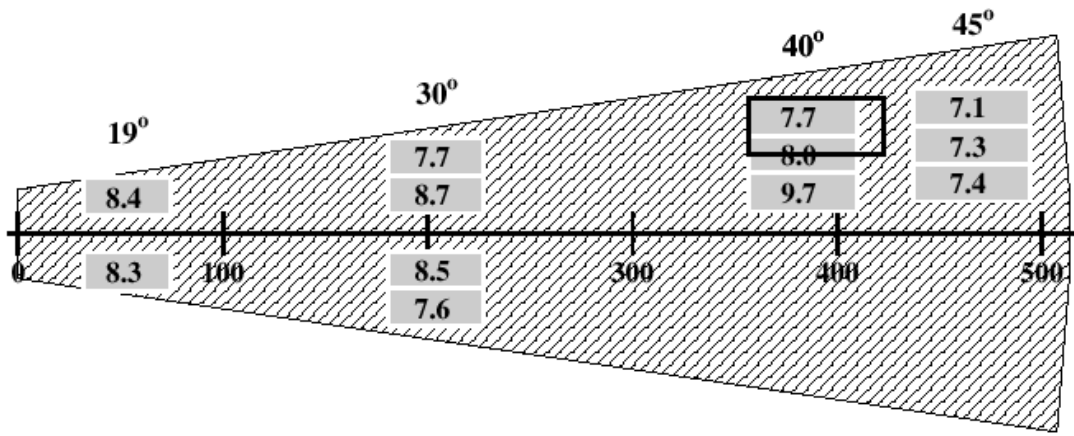

Figure 9: The number of photoelectrons in different points of the counter. The open rectangle designates the area where the  $\pi/K$  separation was measured.

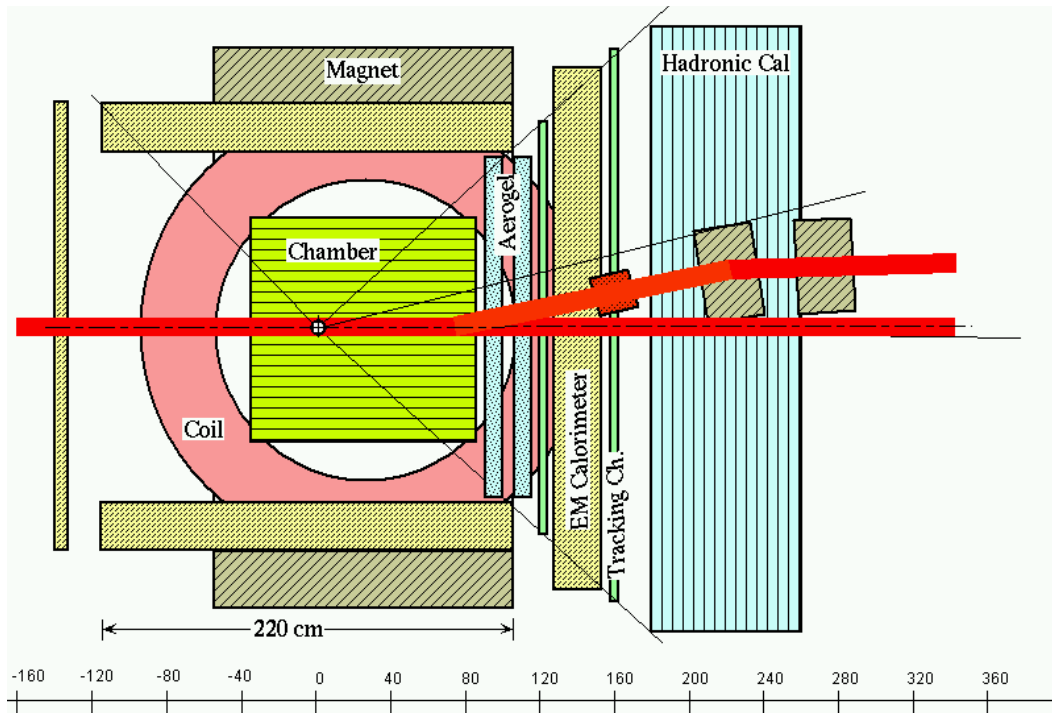

Figure 12: Top view of the PEP-N detector.

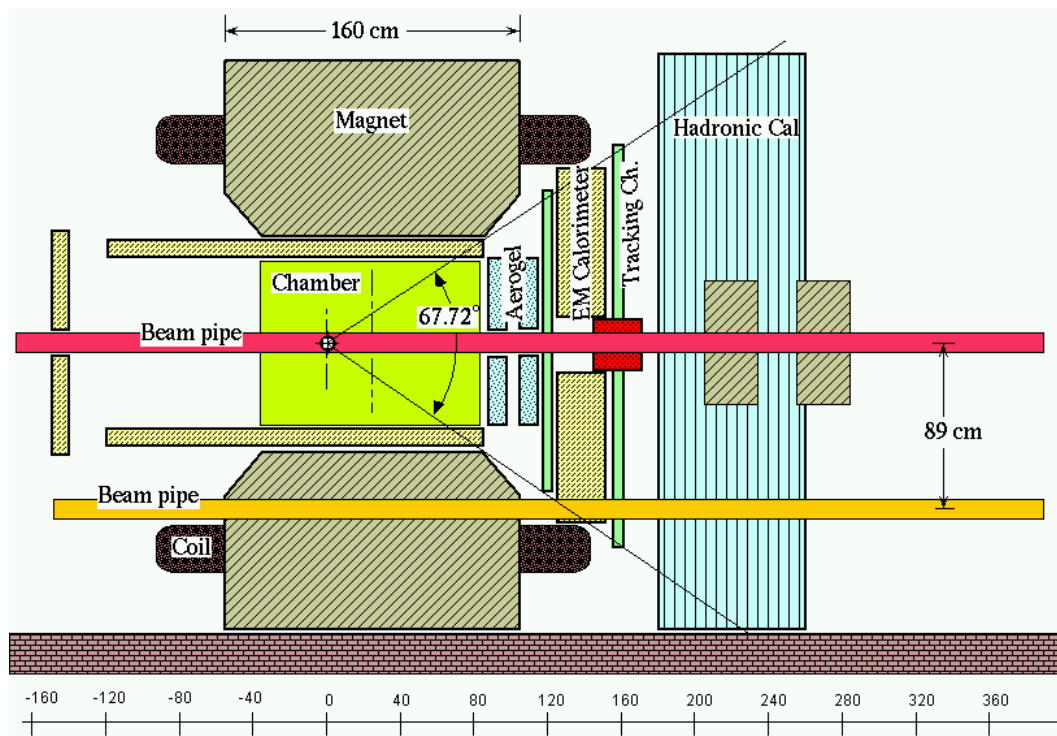

Figure 13: Side view of the PEP-N detector.