

# Multiple Federations in BaBar

Simon Patton  
(LBNL)

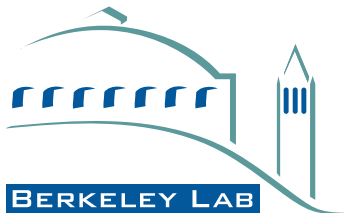

# Overview

- **Babar has too much data for standard Objy federation!**
- **Review number of solutions to extend available space**
- **Decided on Multiple federations in single job**
- **Discuss how this can be used to solve problems**
- **Report on current status**

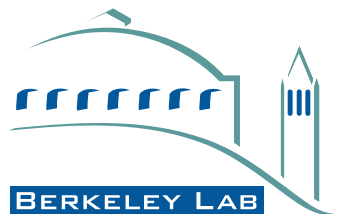

# Mid-2000 Situation

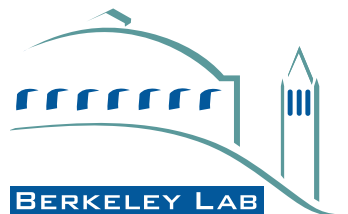
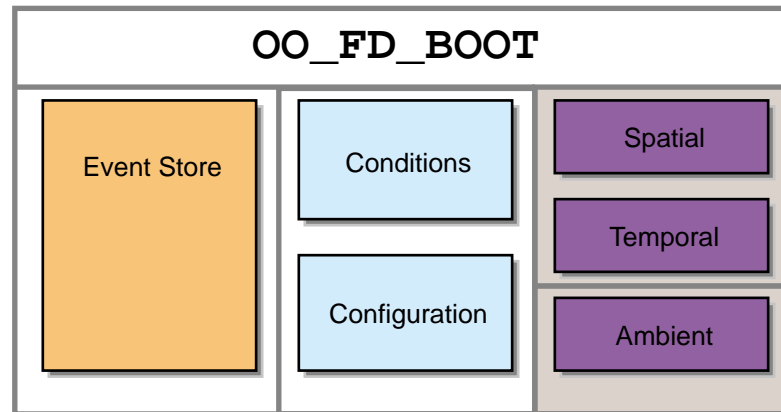

# Limitations

## ➤ Capacity

### ❖ 64 K DbIds

- (DbId management to allow data distribution)

### ❖ File sizes 2GB & 10GB

- Optimum file sizes 250-500 MB

## ➤ Development federations

### ❖ Required copies of Conditions and Configuration data

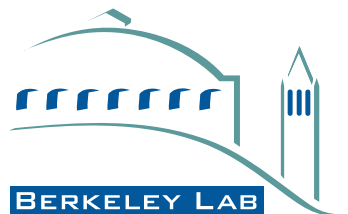

# Possible Solutions

## ➤ Extended DbId's

- ❖ More databases, re-engineer `ooRefHandles`.

## ➤ Multiple-file databases

- ❖ More files, still 64 K units of management.

## ➤ Multiple Federations

- ❖ Open more than one federation in a job.

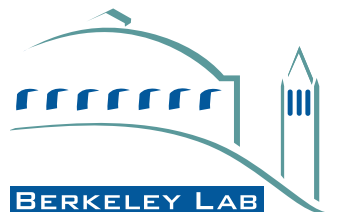

# Multiple Federations selected

- **“Works” out of the box**
- **Schema (inc. physical layout) must match**
  - ❖ Objy 5.x schema not compatible with Objy 6.x
  - ❖ Can not mix page sizes
    - Fixed in Objy 7(?)
- **ooHandles not checked against active ooContext**
  - ❖ Fixed in Objy 7(?)

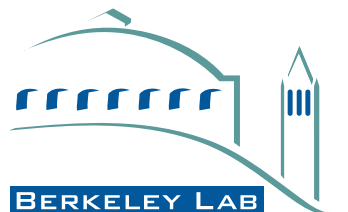

# Migration to Multiple Federations

## ➤ Phase I

### ❖ Domain Divestiture

- Each domain can be in different federation
- Development and implementation of Multiple federation API

## ➤ Phase II

### ❖ Expansion of Event Store

- Increase capacity
- Improve performance

More lock servers

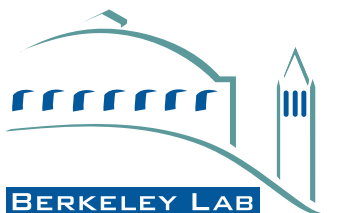

# Features of New API

- **Only one new concept, ‘activation’**
- **Bridge pattern used to support old scheme during migration (see next slide)**
- **Need new inhibit system to pause jobs**
- **Extended authorization API to include Federation level**



# Implementation of API

- **Bridge pattern used to support old scheme during migration**
  - ❖ Old scheme used single **BdbSession** for all domains
  - ❖ New scheme has one **BdbObjyDomain** per domain
    - **BdbObjyDomain** contains **BdbObjyTrans**
    - **BdbObjyTrans** encapsulates **ooContext** and **ooTrans**
    - Can change Federation by changing **BdbObjyTrans**

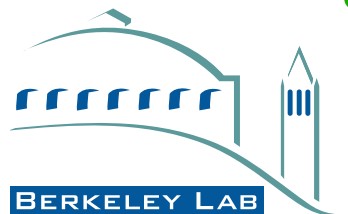

# Domain Divestiture

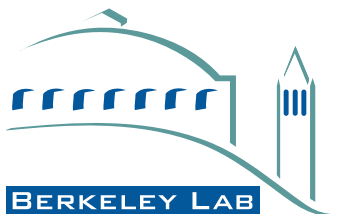
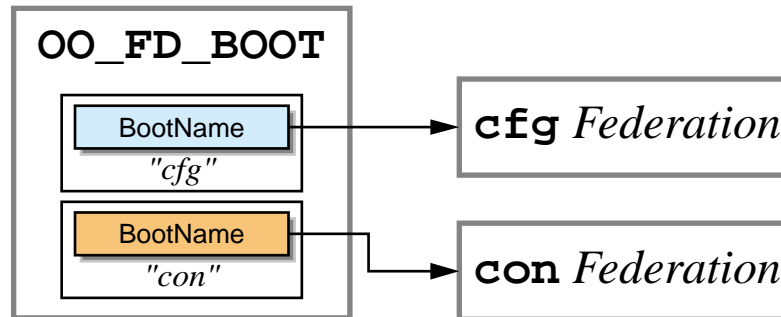

# Expansion of Event Store

- **Requires compatibility with current store**
- **All data for one event is within single federation**
- **Skim collections “borrow” events**
  - ❖ **Must be in same federation as Event**
- **Reprocessing collections “borrow” headers**
  - ❖ **Must be in same federation as Event**

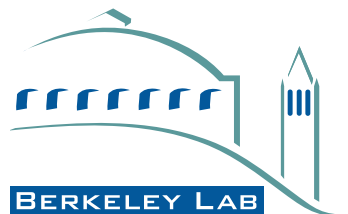

# Event Structure

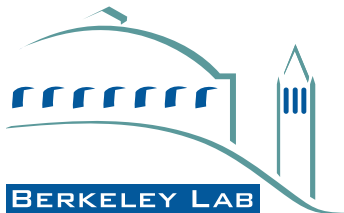
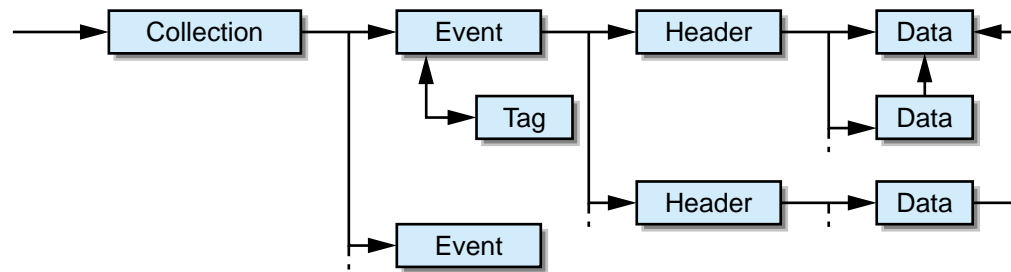

# Event Borrowing

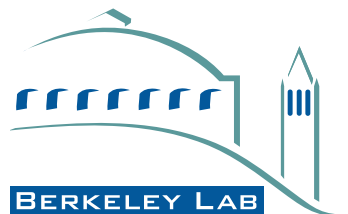
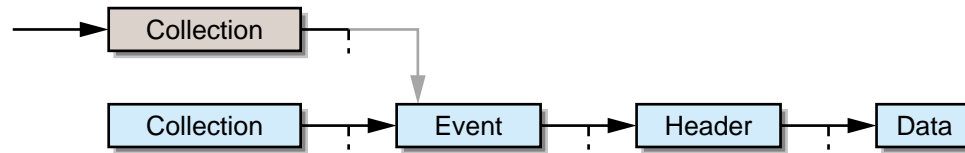

# Header Borrowing

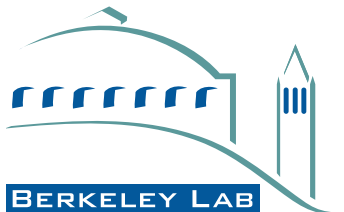
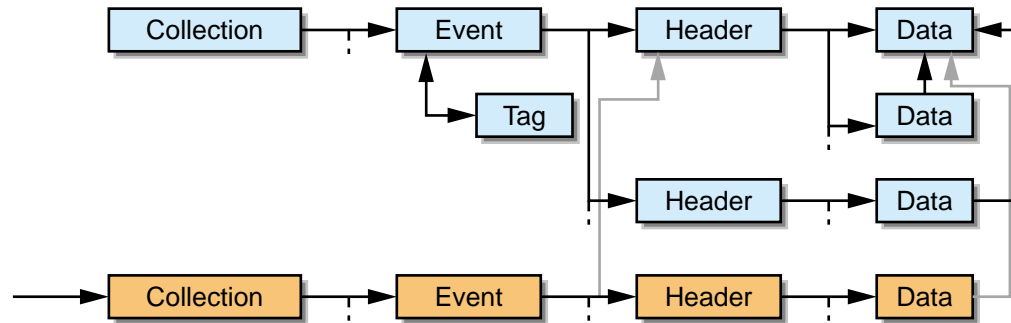

# Expansion of Event Store (II)

- **Temporal division of Event Store**
- **Each Federation self contained (inc. other domains)**
- **New Collection introduced to bridge across federations**
- **Requires re-initialization of “default” federation**
- **Iteration is transparent to client**

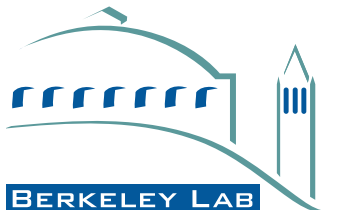

# Bridge Collections

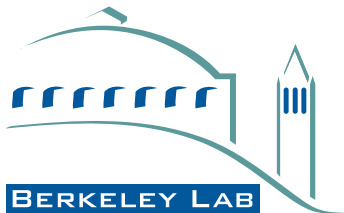
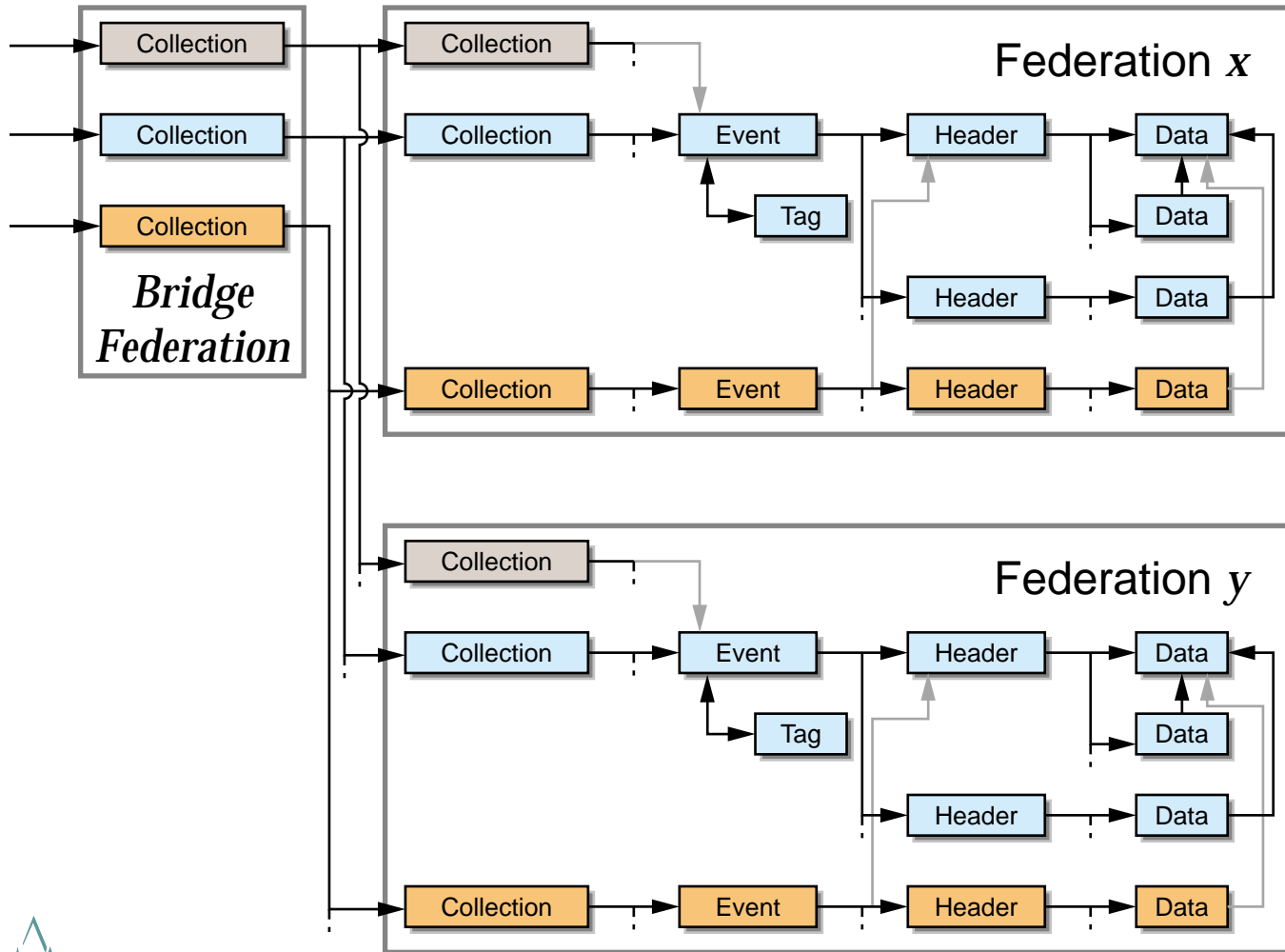

# Bridge Collection Iteration

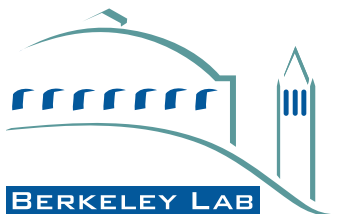
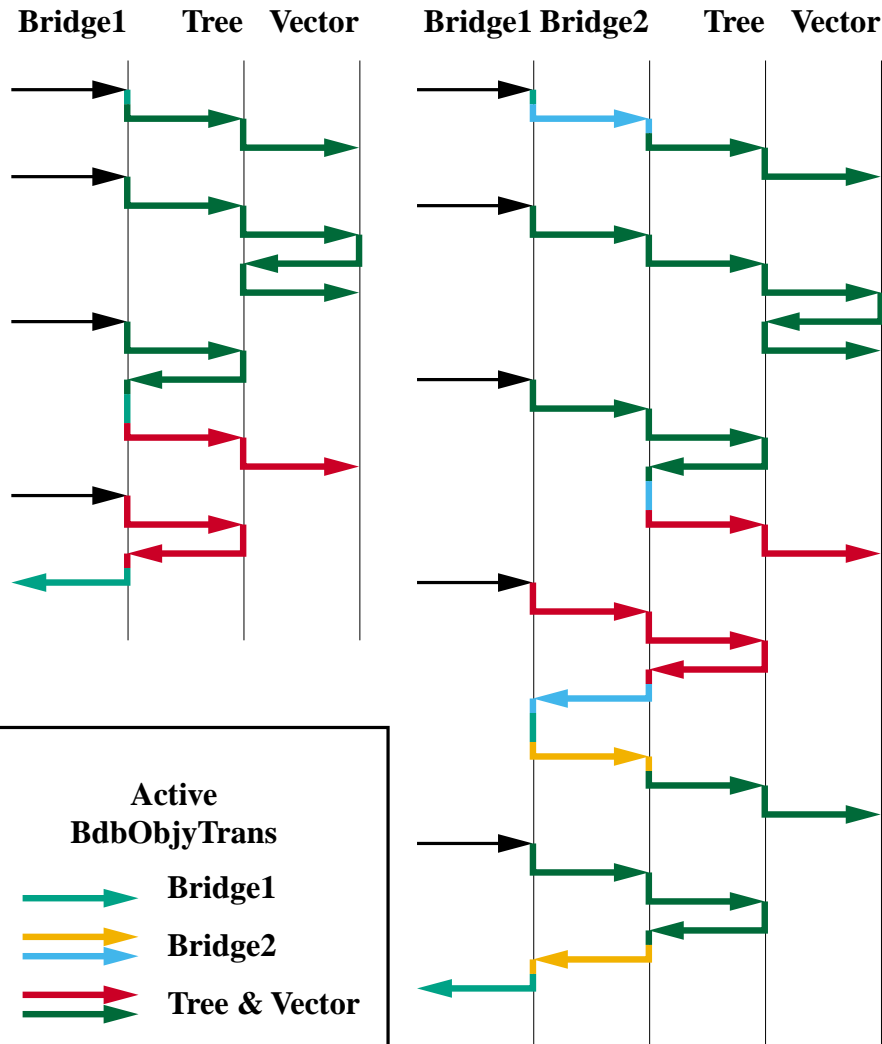

# Current Status

- **Implemented and released or in testing most components**
  - ❖ API
  - ❖ Domain Divestiture
  - ❖ Read only Bridge Collections
- **To be done**
  - ❖ Writable Bridge Collections
  - ❖ (Possible extension to support multi-threading)



# “Standard” Writable Bridge Collection

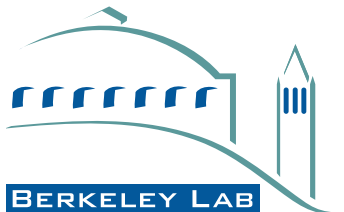
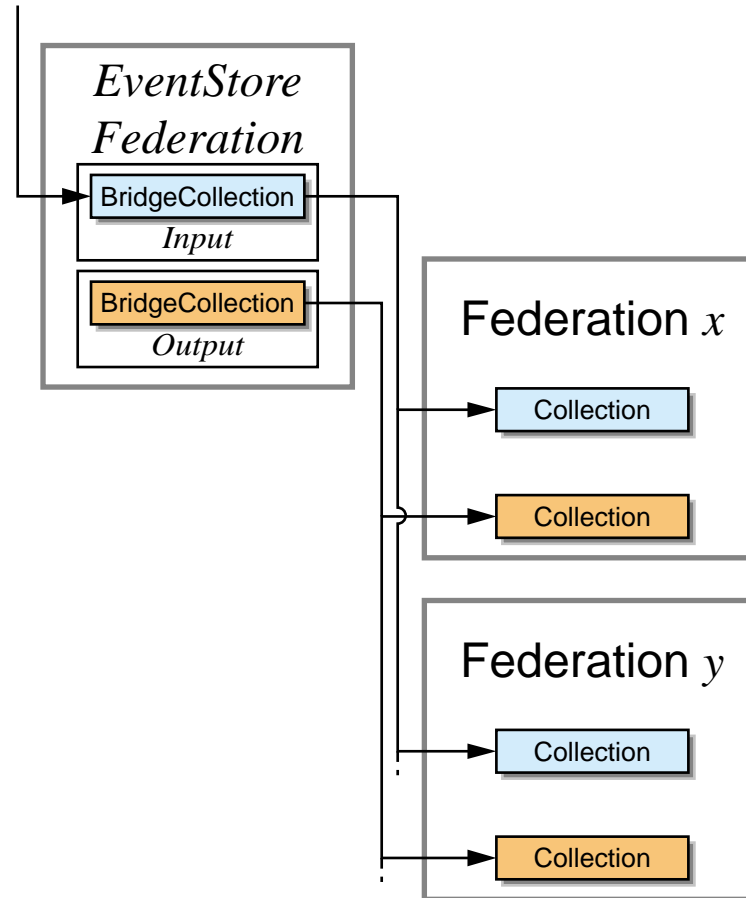

# “AIO” Writable Bridge Collection

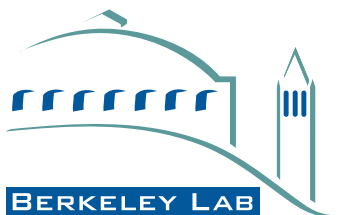
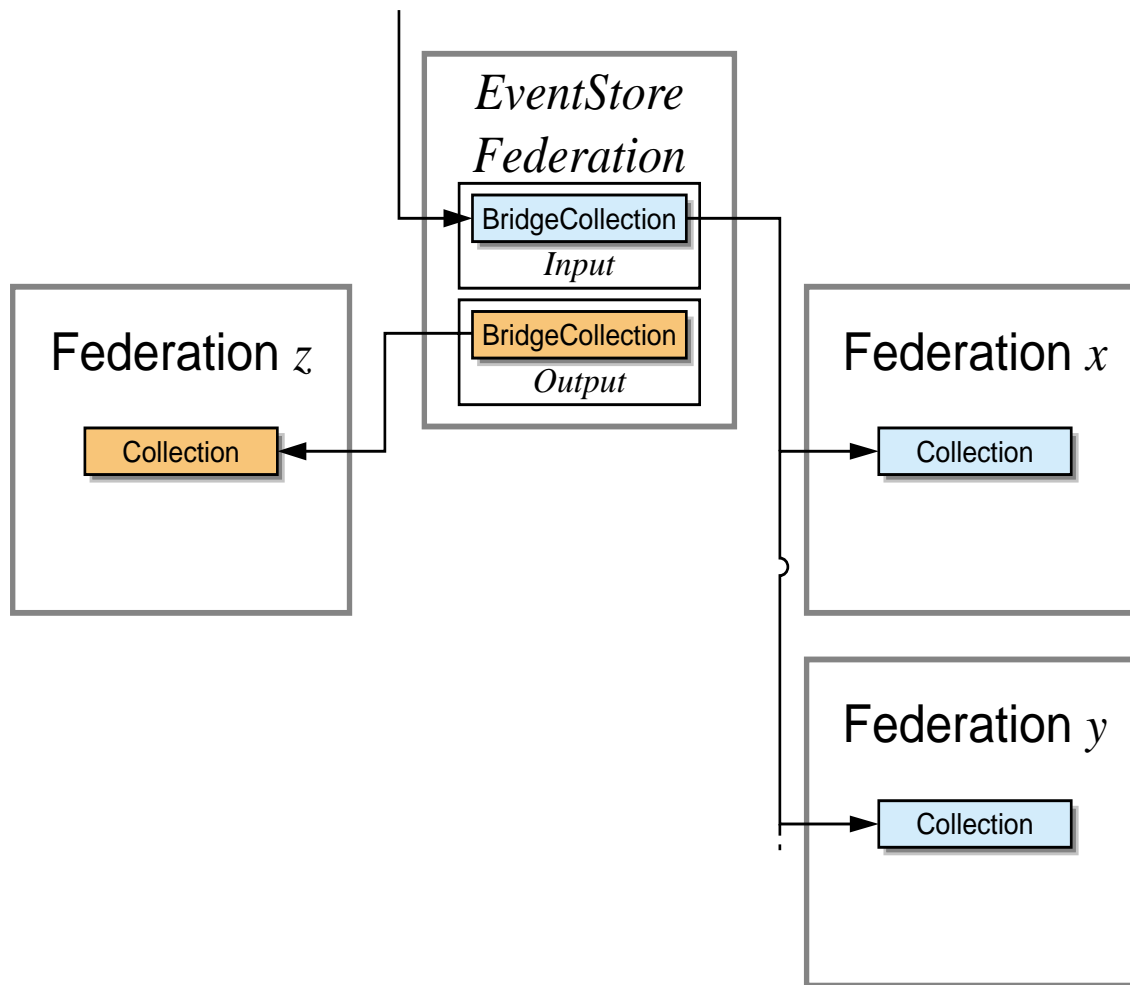

# Summary

- **64K DbId limit was becoming a problem**
- **Review number of solutions and selected multiple federations**
- **Minor changes in API as domain already provided separation**
- **Most of it implemented**
- **Looking good!**

