

DIRC, Particle Identification for BABAR

Detection of Internally Reflected Cherenkov light



Colorado State, CEA, DAPNIA-Saclay,
LAL Orsay, LBNL-Berkeley,
LPNHE Paris 6 at Paris 7,
L'EPNHE de l'Ecole Polytechnique,
Rutgers University, SLAC-Stanford,
UC Santa Barbara, University of Cincinnati

Stefan Spanier, Jochen Schwiening

Motivation of the DIRC

The BaBar detector at PEP-II is dedicated to measuring B decays at the Y(4s) resonance with asymmetric beam energies. An important issue to study *CP violation* is the ability to tag decays of b-quark versus \bar{b} -quark meson decays and to separate charged pions from charged kaons for particle momenta up to 4 GeV/c in B decays (e.g. distinguish $B^0 \rightarrow \pi^+ \pi^-$ from $B^0 \rightarrow K^+ \pi^-$).

Principle of the DIRC

A charged particle with velocity $\beta = v/c$ generates Cherenkov photons in quartz with angle θ_c with respect to its direction:

$$\cos \theta_c(\lambda) = 1/\beta \cdot n(\lambda)$$

- $n(\lambda)$: refraction index (DIRC average is 1.47)
- λ : wavelength of Cherenkov photon

⇒ particle identification by comparing the average photon emitting angle for a track measured by the DIRC with the momentum p measured in the tracking system (vertex detector, drift chamber).

• Bar captures photons due to total reflection (surrounded by air $n_2 = 1$).

⇒ acts as light guide; the original photon direction is preserved (up to ambiguities left/right and up/down).

• Extract photons at one end of the bar into water ($n_w = 1.33$) and guide light to photomultiplier plane. In addition water magnifies the exit angle by a factor n/n_w .

⇒ pinhole focussing (principle of a pinhole camera):

The transversal bar dimensions are small ("hole") compared to the distance to the photomultiplier plane ("screen").

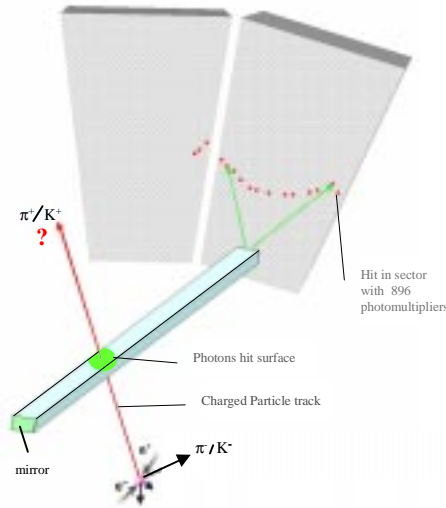

The **photon detector** is an array of 10752 conventional photomultipliers (PMT) mounted in a water tank which is filled with 6000 l purified water. The tank is located outside the magnet yoke (*stand off box: SOB*) in a magnetic shielding to ensure proper operation of the tubes. The acceptance peaks at 410 nm. The PMTs measure photon arrival times in 0.5 ns bins with a resolution of 1.8 ns.

One of the SOB doors is open showing the phototubes.



View from backward end of closed SOB. Each of the 12 sectors carries a high voltage crate.

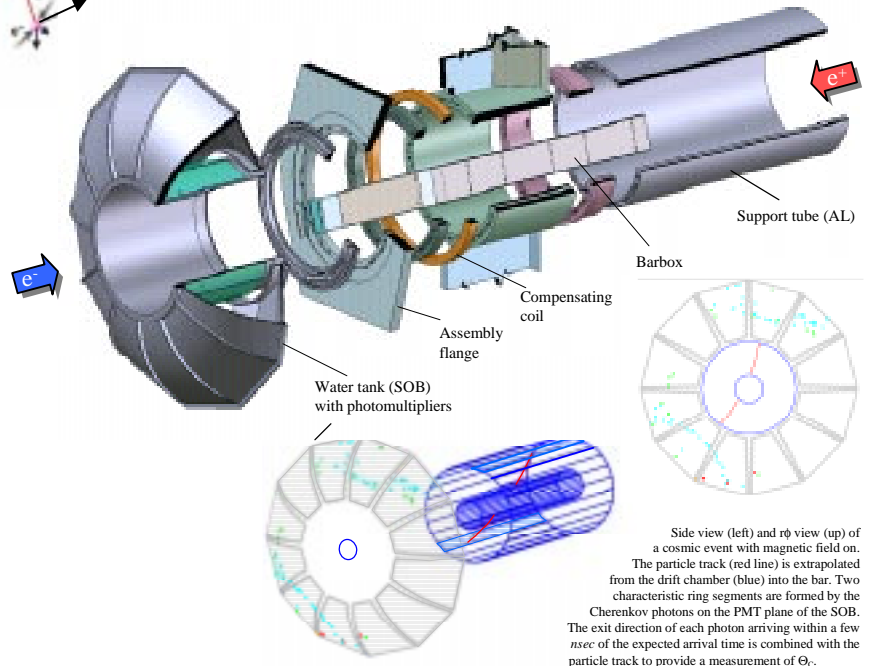

Side view (left) and $\phi\phi$ view (up) of a cosmic event with magnetic field on. The particle track (red line) is extrapolated from the drift chamber (blue) into the bar. Two characteristic ring segments are formed by the Cherenkov photons on the PMT plane of the SOB. The exit direction of each photon arriving within a few *nsec* of the expected arrival time is combined with the particle track to provide a measurement of θ_c .

The **Cherenkov radiators** are 4.9 m long rectangular bars (17mm thick, 35 mm wide) made of *synthetic fused silica*. Not all photons are caught by total reflection. Losses in the bar are due to absorption in the bulk material and reflections on the surface imperfections. A typical photon has a wavelength of about 400 nm (visible, blue), has a pathlength of 6 - 10 m and experiences 300 bounces before exiting. The required high optical quality of the material became available after the demand for optical fibers. *Fused silica* is a synthetic amorphous silicon dioxide which can be polished to high surface precision and is very radiation hard compared to natural quartz. The surfaces are first ground to the final size, then lapped to reduce subsurface damage and finally polished. The typical RMS surface roughness is 0.5nm. The average transmission achieved in the DIRC quartz bars is 99.8% / m.



The picture shows a DIRC bar during a reflectivity measurement using a HeCd laser beam (442 nm). The internal reflected beam is also visible.

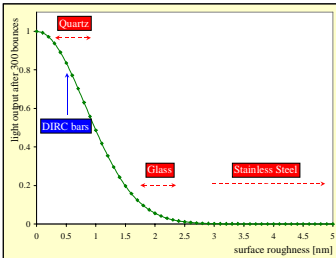

Comparison of typical polish qualities for different materials. The average surface reflectivity of the DIRC quartz exceeds 99.9% as expected for the surface polish of 0.5 nm (RMS).

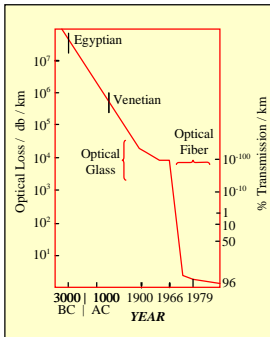

Historical evolution of glass light transmission in the visible light regime, where the DIRC operates.

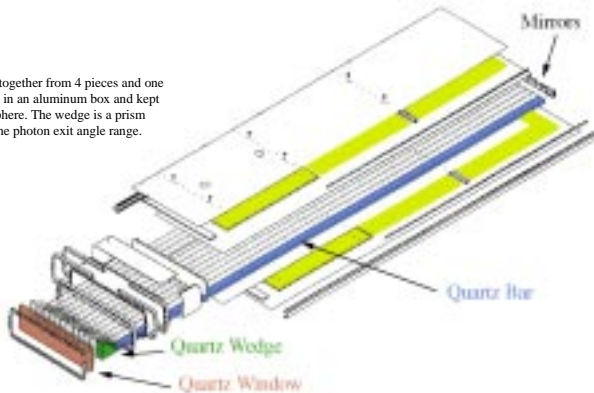

Barbox
12 bars, each glued together from 4 pieces and one wedge, are mounted in an aluminum box and kept in a nitrogen atmosphere. The wedge is a prism which compresses the photon exit angle range.

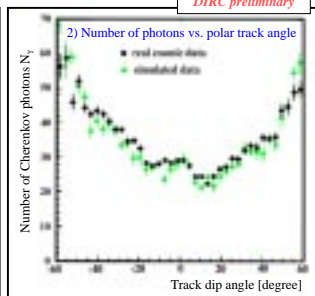
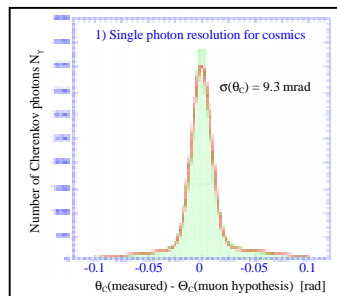

Performance

- The **single photon θ_c resolution** is determined by
 - chromatic smearing of its production (5.4 mr),
 - bar geometry and imaging granularity (7.0 mr),
 - smearing effects during propagation down the bar.
- The **photon number N_c** is shown for cosmic particles versus the track dip angle with respect to the bar length axis. Due to the boost in collision data large dip angles are preferred for charged reaction products and hence the average photon number is higher.
- The ability of **particle identification** refers finally to the potential to separate bands in the plane Cherenkov angle θ_c of the track versus momentum. Here, θ_c is a combination of the individual $\theta_{c,i}$ measurements. Hence, the uncertainty on the track Cherenkov angle is given by:

$$\sigma^2(\theta_c) = (\sigma^2(\theta_{c,i})/N_c) + \sigma^2(p)$$

