

Note about bypass capacitors: 47 nF ceramic capacitors will do just as well as 100 nF ones. BTW, C1-C12 do not really do anything, since RC is just $147 \text{ Ohm} * C =$ something like 10 microseconds.

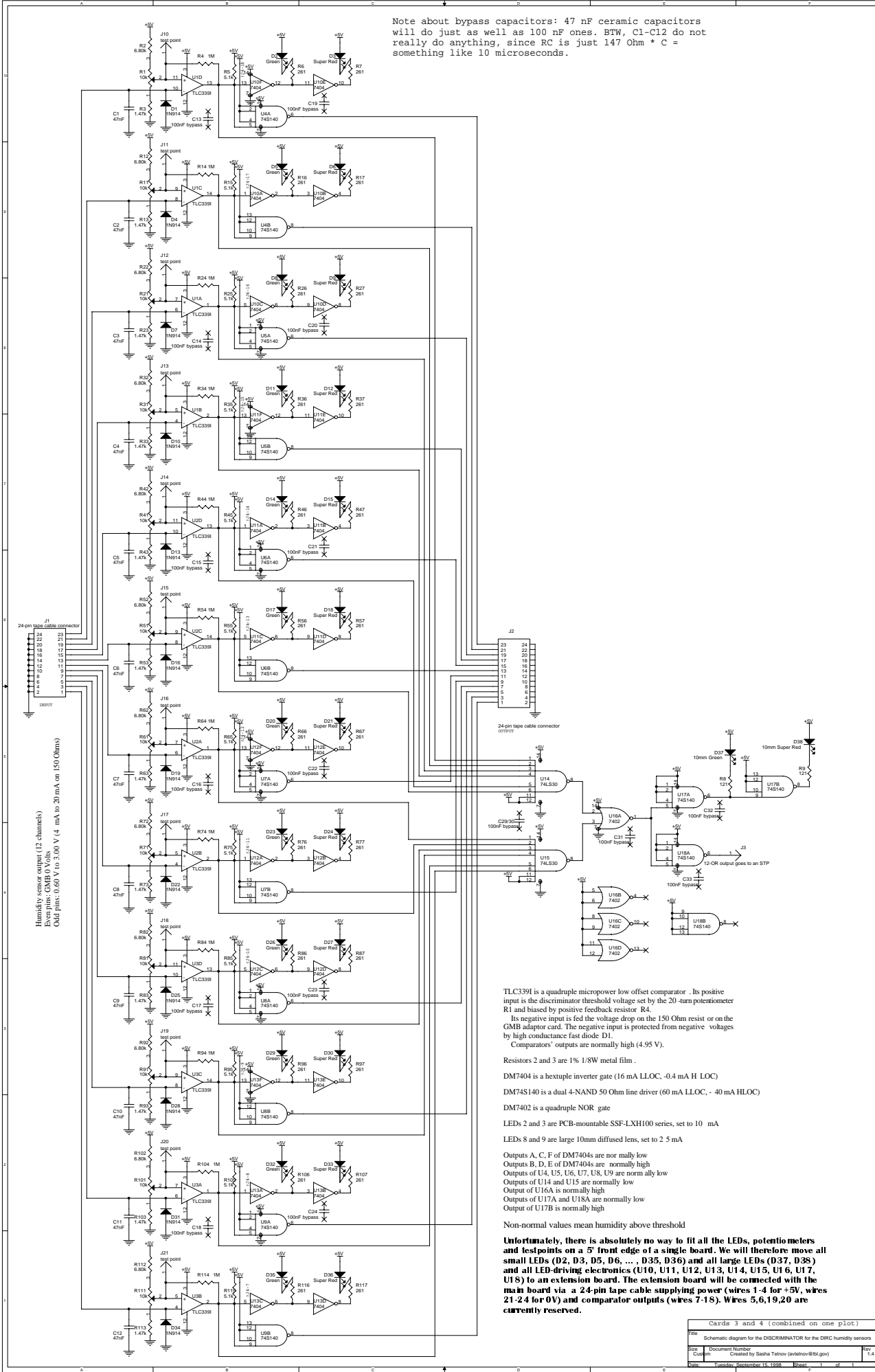

Humidity sensor output (12 channels)
Even pins: GMB 0 Volts
Odd pins: 0.6V to 3.0V (4 mA to 20 mA on 150 Ohms)

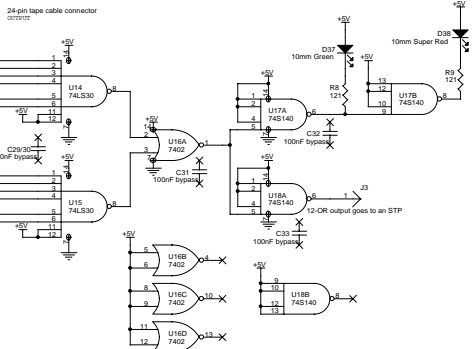

TLC339I is a quadropole micropower low offset comparator . Its positive input is the discriminator threshold voltage set by the 20k turn potentiometer R1 and biased by positive feedback resistor R4.
Its negative input is fed the voltage drop on the 150 Ohm resist or on the GMB adaptor card. The negative input is protected from negative voltages by high conductance fast diode D1.
Comparators' outputs are normally high (4.95 V).
Resistors 2 and 3 are 1% 1/8W metal film .
DM7404 is a hexuple inverter gate (16 mA LLOC, -0.4 mA H LOC)
DM74140 is a dual 4-NAND 50 Ohm line driver (60 mA LLOC, - 40 mA HLOC)
DM7402 is a quadropole NOR gate
LEDs 2 and 3 are PCB-mountable SSF-LXH100 series, set to 10 mA
LEDs 8 and 9 are large 10mm diffused lens, set to 2.5 mA
Outputs A, C, F of DM7404s are nor mally low
Outputs B, D, E of DM7404s are normally high
Outputs of U4, U5, U6, U7, U8, U9 are norm ally low
Outputs of U14 and U15 are normally low
Output of U16A is normally high
Outputs of U17A and U18A are normally low
Output of U17B is normally high

Non-normal values mean humidity above threshold
Unfortunately, there is absolutely no way to fit all the LEDs, potentiometers and testpoints on a 5" front edge of a single board. We will therefore move all small LEDs (D2, D3, D5, D6, ... - D35, D36) and all large LEDs (D37, D38) and all LED-driving electronics (U10, U11, U12, U13, U14, U15, U16, U17, U18) to an extension board. The extension board will be connected with the main board via a 24-pin tape cable supplying power (wires 1-4 for +5V, wires 21-24 for 0V) and comparator outputs (wires 7-18). Wires 5,6,19,20 are currently reserved.

Cards 3 and 4 (combined on one plot)			
File	Schematic diagram for the DISCRIMINATOR for the DRC humidity sensors		
Size	Document Number:	Created by Sasha Telnov (sashet@td.gov)	
Cursum	Created by	Sasha Telnov (sashet@td.gov)	
Date	Version	Sheet No.	1 of 1